

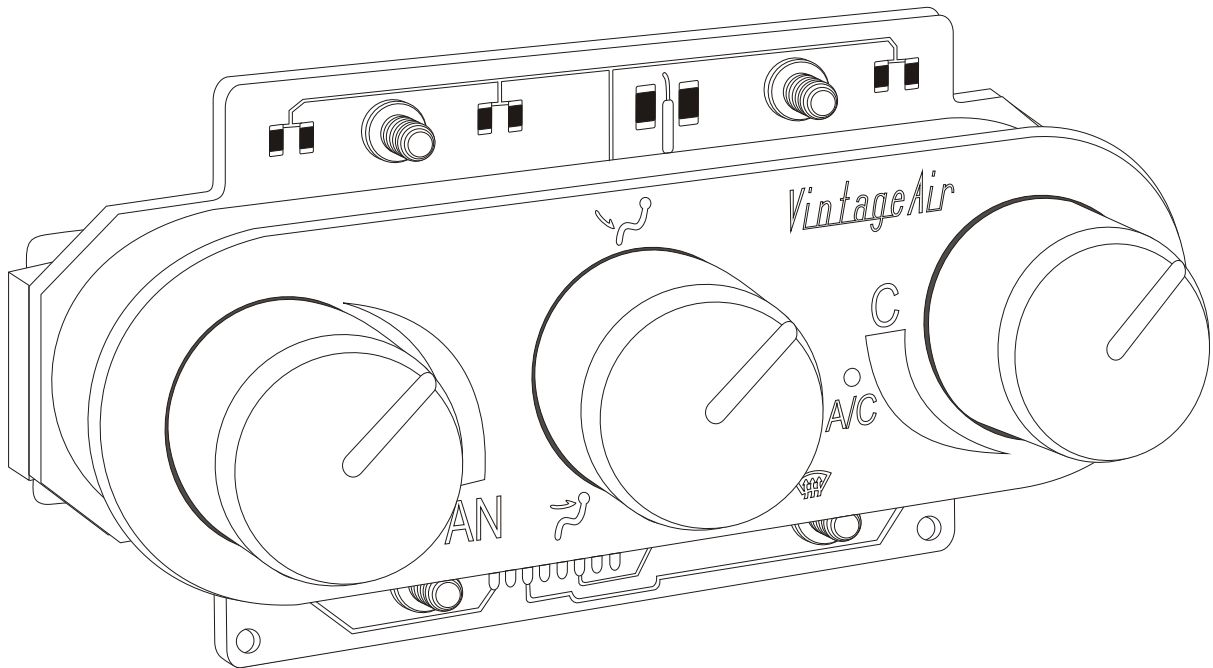

STREAMLINE

**3 KNOB PANEL
491210-RUA**



18865 GOLL ST. - SAN ANTONIO, TX. - 78266 ph.210-654-7171 - fax 210-654-3113

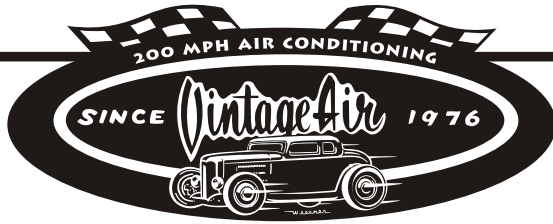

TABLE OF CONTENTS

PAGES

1. COVER
2. TABLE OF CONTENTS
3. PACKING LIST
4. CONTROL PANEL TEMPLATE & INSTALLATION
5. CONTROL PANEL INSTALLATION CONT.
6. OPERATION OF CONTROLS
7. WIRING DIAGRAM
8. THERMOSTAT ADJUSTMENT
9. CONTROL PANEL KIT PACKING LIST



STREAMLINE 3 KNOB CONTROL PANEL

CONTROL PANEL PACKING LIST

**CONTROL PANEL
491210-RUA**

No.	QTY.	PART No.	DESCRIPTION
1.	1	491209-RUA	STREAMLINE 3 KNOB CONTROL PANEL
2.	1	232007-VUR	GEN IV UNIVERSAL CONTROL HARNESS (TYPE C)

**** BEFORE BEGINNING INSTALLATION OPEN ALL PACKAGES AND CHECK CONTENTS OF SHIPMENT. PLEASE REPORT ANY SHORTAGES DIRECTLY TO VINTAGE AIR WITHIN 15 DAYS. AFTER 15 DAYS, VINTAGE AIR WILL NOT BE RESPONSIBLE FOR MISSING OR DAMAGED ITEMS.**

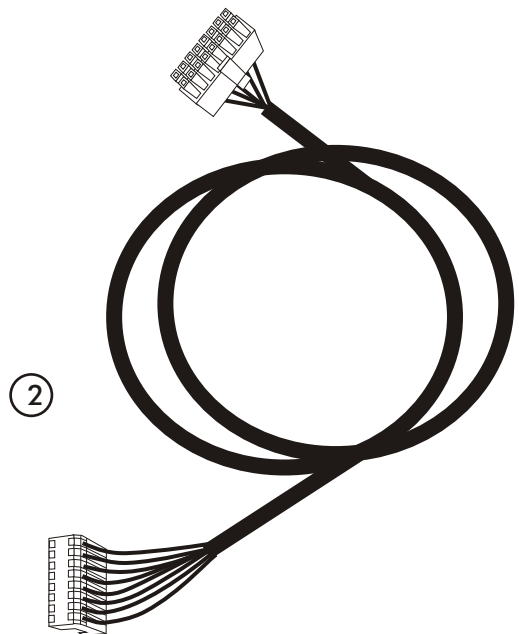
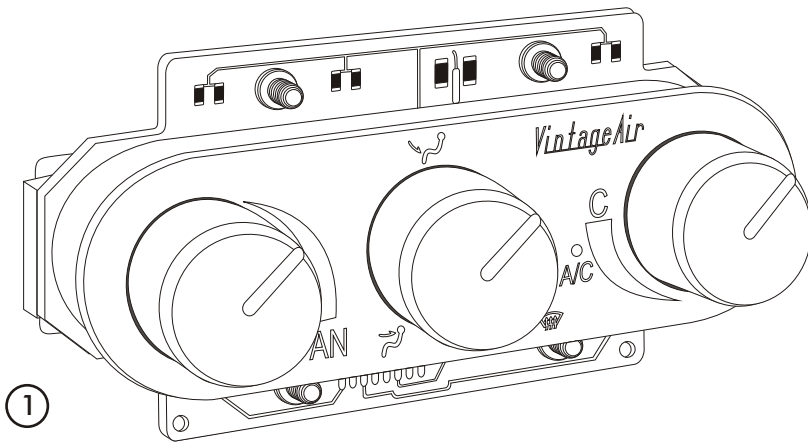



STREAMLINE 3 KNOB CONTROL PANEL

STREAMLINE 3 KNOB CONTROL PANEL TEMPLATE

TEMPLATE FOR 491210-RUA

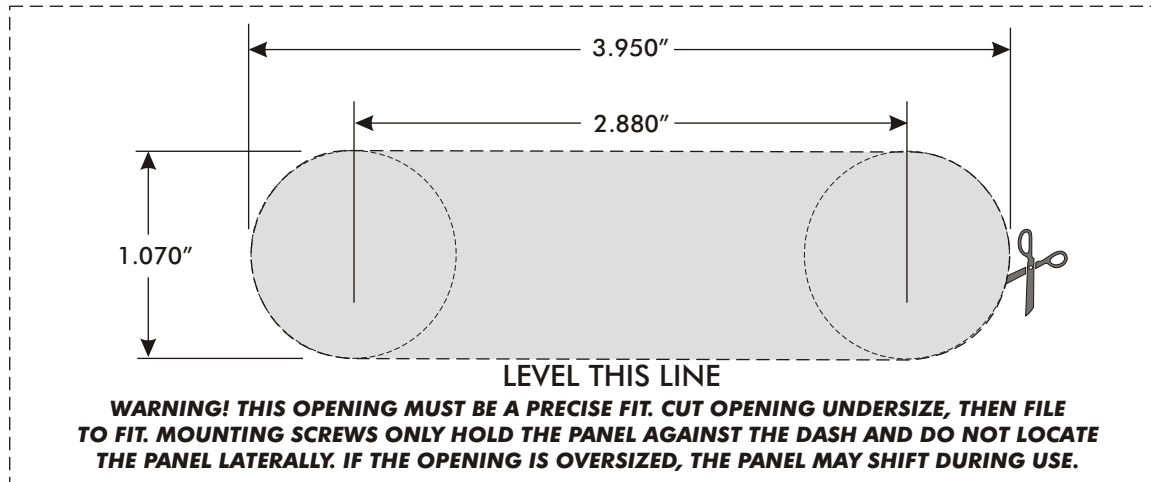

CONTROL PANEL INSTALLATION

- SELECT A SUITABLE LOCATION FOR THE CONTROL PANEL. CONSIDER HEATER CONTROL VALVE LOCATION, WIRING HARNESS LENGTH AND OPERATOR CONVENIENCE.
- AFTER SELECTING A LOCATION FOR THE PANEL, MASK THE AREA 1 1/2" (TALL) x 4 1/2" (WIDE).
- CUT OUT TEMPLATE ABOVE AND CUT OUT THE GREY SECTION OF TEMPLATE ALONG DOTTED LINE.
- PLACE TEMPLATE IN DESIRED POSITION ON DASH, BE SURE TO LEVEL TEMPLATE AND TAPE INTO PLACE ON DASH.
- MARK DASH WITH MARKER OR SCRIBE CONTROL PANEL OPENING ON DASH. CUT OUT OPENING FOR PANEL IN DASH.

WARNING! THIS OPENING MUST BE A PRECISE FIT. CUT OPENING UNDERSIZE, THEN FILE TO FIT. MOUNTING SCREWS ONLY HOLD THE PANEL AGAINST THE DASH AND DO NOT LOCATE THE PANEL Laterally. IF THE OPENING IS OVERSIZED, THE PANEL MAY SHIFT DURING USE.

- INSTALL CONTROL PANEL FACE THROUGH OPENING IN DASH, PLACE CONTROL PANEL PC BOARD ASM BEHIND DASH AND SECURE TO THE CONTROL PANEL FACE USING THE (4) 8-32 x 3/8 PH SCREWS. SEE FIGURE 1, PAGE 5
- PLUG CONTROL PANEL WIRING HARNESS INTO CONTROL PANEL AND THE ECU ON EVAPORATOR, SEE FIGURE 2, PAGE 5.
- WIRE ACCORDING TO WIRING DIAGRAM ON PAGE 7.



STREAMLINE 3 KNOB CONTROL PANEL

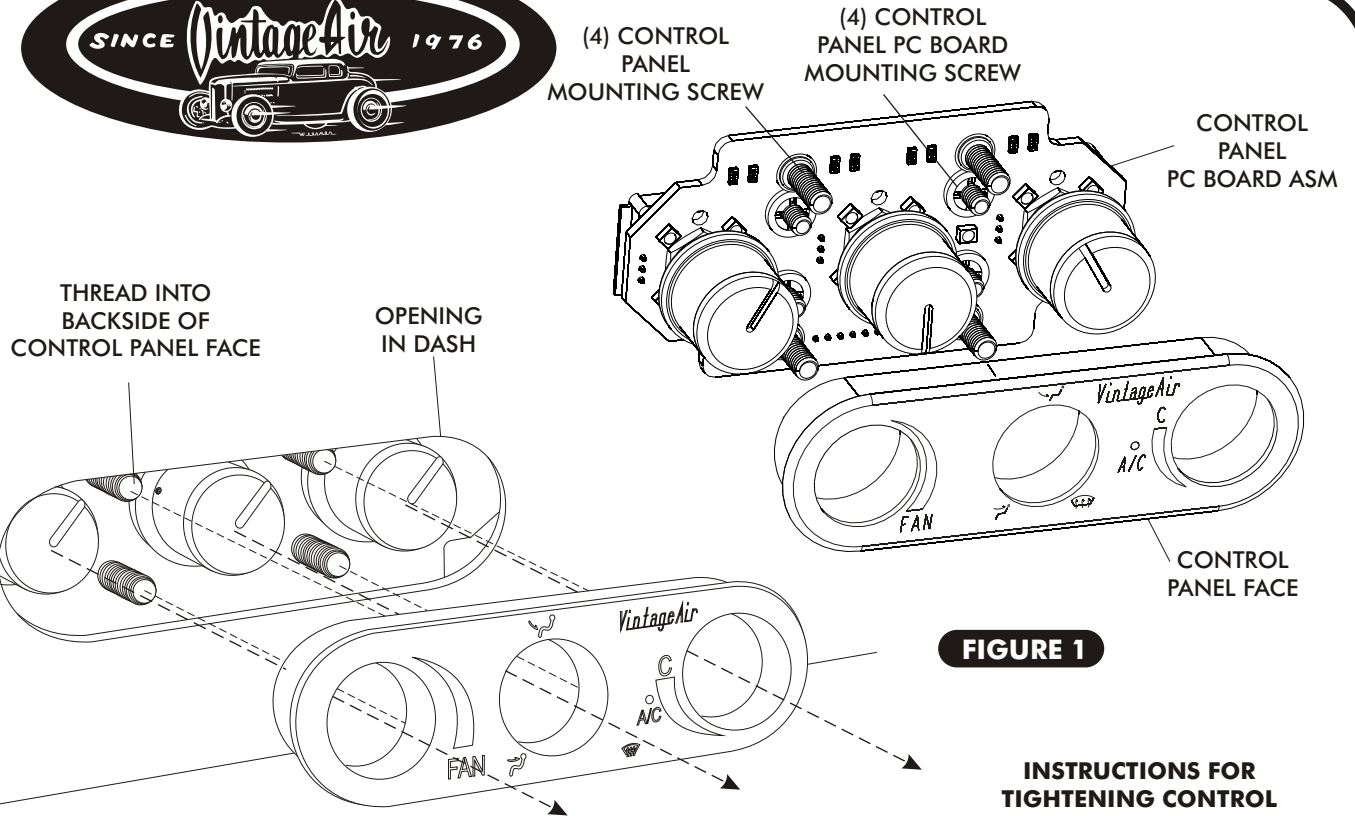

FIGURE 1

INSTRUCTIONS FOR TIGHTENING CONTROL PANEL MOUNTING SCREWS
 HAND TIGHTEN CONTROL PANEL MOUNTING SCREWS UNTIL SCREW CONTACTS BACKSIDE OF DASH, THEN USING A SCREWDRIVER TIGHTEN 1/2 A TURN.
WARNING: DO NOT OVER TIGHTEN, OVER TIGHTENING MAY CAUSE DAMAGE TO PC BOARD OR DASH.

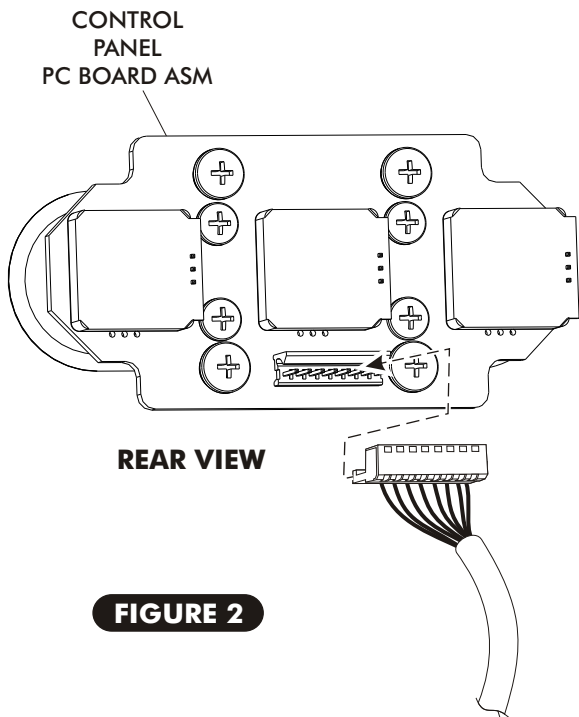

FIGURE 2

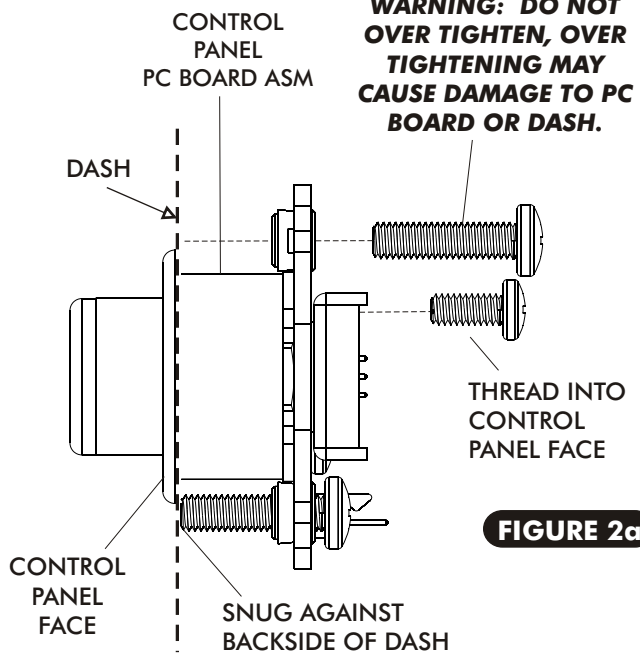
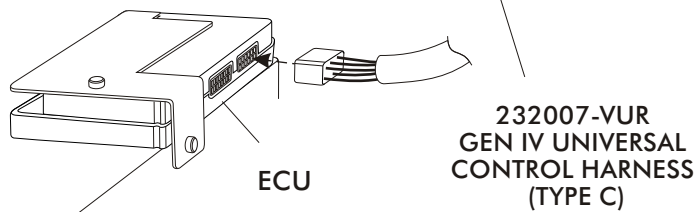

FIGURE 2a



SIDE VIEW



STREAMLINE 3 KNOB CONTROL PANEL

491210-RUA STREAMLINE 3 KNOB CONTROL PANEL OPERATION

NOTE:

- **THE TEMPERATURE KNOB TOGGLES BETWEEN A/C AND HEAT MODES.** FOR A/C MODE ROTATE THE TEMPERATURE KNOB CLOCKWISE ALL THE WAY TO THE RIGHT TO ENGAGE THE COMPRESSOR (BLUE A/C LIGHT WILL COME ON IN A/C MODE). ROTATE TEMPERATURE KNOB COUNTER CLOCKWISE TO SELECT DESIRED TEMPERATURE. FOR HEAT MODE ROTATE THE TEMPERATURE KNOB COUNTER CLOCKWISE ALL THE WAY TO THE LEFT TO DISENGAGE THE COMPRESSOR (BLUE A/C LIGHT WILL TURN OFF). ROTATE TEMPERATURE KNOB CLOCKWISE TO SELECT DESIRED TEMPERATURE
- **ALL SWITCHES ARE VARIABLE BETWEEN POSITIONS, SYSTEM WILL PERFORM A BLEND BETWEEN THE FUNCTIONS**

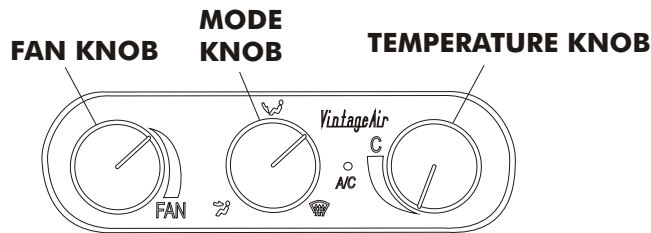

SYSTEM OFF

TURNING THE FAN KNOB COUNTER CLOCKWISE ALL THE WAY TO THE LEFT WILL SHUT DOWN THE SYSTEM IN ANY MODE.



VENT HEAT MODE

ROTATE FAN KNOB CLOCKWISE TO DESIRED FAN SPEED. ROTATE MODE KNOB TO DASH POSITION. ROTATE THE TEMPERATURE KNOB COUNTER CLOCKWISE ALL THE WAY TO THE LEFT TO DISENGAGE THE COMPRESSOR (BLUE A/C LIGHT WILL TURN OFF). ROTATE TEMPERATURE KNOB CLOCKWISE TO SELECT DESIRED TEMPERATURE.

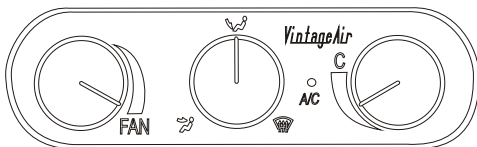

FLOOR HEAT MODE

ROTATE FAN KNOB CLOCKWISE TO DESIRED FAN SPEED. ROTATE MODE KNOB TO FLOOR POSITION. ROTATE THE TEMPERATURE KNOB COUNTER CLOCKWISE ALL THE WAY TO THE LEFT TO DISENGAGE THE COMPRESSOR (BLUE A/C LIGHT WILL TURN OFF). ROTATE TEMPERATURE KNOB CLOCKWISE TO SELECT DESIRED TEMPERATURE.

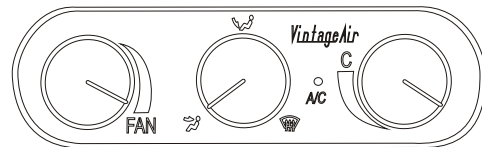

A/C MODE

ROTATE FAN KNOB CLOCKWISE TO DESIRED FAN SPEED. ROTATE MODE KNOB TO DASH POSITION. ROTATE THE TEMPERATURE KNOB CLOCKWISE ALL THE WAY TO THE RIGHT TO ENGAGE THE COMPRESSOR (BLUE A/C LIGHT WILL COME ON IN A/C MODE). ROTATE TEMPERATURE KNOB COUNTER CLOCKWISE TO SELECT DESIRED TEMPERATURE.

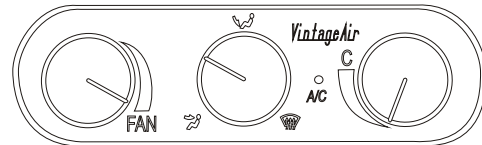

BI-LEVEL HEAT MODE

ROTATE FAN KNOB CLOCKWISE TO DESIRED FAN SPEED. ROTATE MODE KNOB BETWEEN FLOOR AND DASH POSITION. ROTATE THE TEMPERATURE KNOB COUNTER CLOCKWISE ALL THE WAY TO THE LEFT TO DISENGAGE THE COMPRESSOR (BLUE A/C LIGHT WILL TURN OFF). ROTATE TEMPERATURE KNOB CLOCKWISE TO SELECT DESIRED TEMPERATURE.



DEFROST/DE-FOG MODE

ROTATE FAN KNOB CLOCKWISE TO DESIRED FAN SPEED. ROTATE MODE KNOB TO DEFROST POSITION. NOTE: THE COMPRESSOR WILL AUTOMATICALLY ENGAGE IN THE DEFROST POSITION, BUT THE BLUE A/C LIGHT WILL NOT COME ON. ROTATE TEMPERATURE KNOB CLOCKWISE TO SELECT DESIRED TEMPERATURE.



STREAMLINE 3 KNOB CONTROL PANEL

THERMOSTAT ADJUSTMENT

491210-RUA STREAMLINE 3 KNOB CONTROL PANEL OPERATION

(SHOWN BELOW FOR REPRESENTATIONAL PURPOSES. IF USING OPTIONAL PANEL, REFER TO CONTROL PANEL KIT INSTRUCTIONS SUPPLIED WITH PANEL FOR OPERATION PROCEDURES)

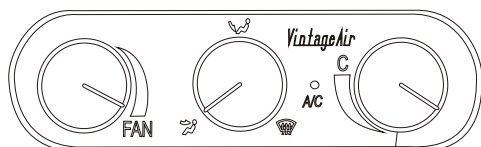

ADJUST THE TEMPERATURE KNOB TO THE LEFT OR RIGHT TO REGULATE TEMPERATURE

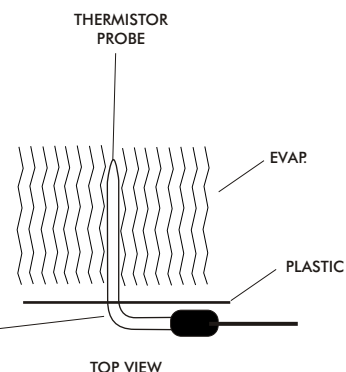
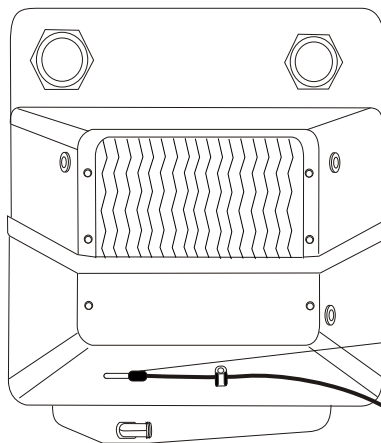

NOTE: GEN IV UNITS DO NOT HAVE A REMOTE THERMOSTAT. THE THERMISTOR PROBE INSTALLED IN THE EVAPORATOR SERVES AS THE THERMOSTAT WHICH IS CONTROLLED BY THE TEMPERATURE KNOB ON THE CONTROL PANEL

AIR CONDITIONING ADJUSTMENTS:

- THE AIR CONDITIONER TEMPERATURE KNOB CONTROLS COIL TEMPERATURE AND TEMP BLEND DOOR POSITION.
- ADJUSTING THE KNOB TO THE RIGHT MAKES THE SYSTEM OPERATE COLDER. IF THE TEMPERATURE KNOB IS SET TOO COLD THE EVAPORATOR MAY "ICE UP" UNDER HIGH HUMIDITY CONDITIONS- THE EVAPORATOR COIL IS RESTRICTED WITH ICE AND COLD AIR FLOW WILL BE REDUCED.
- ADJUSTING THE KNOB TO THE LEFT MAKES THE SYSTEM OPERATE WARMER.
- ADJUST TEMPERATURE KNOB FOR OPTIMUM COMFORT.

ADJUSTING A/C TEMPERATURE KNOB

- TO PREVENT EVAPORATOR FROM FREEZING UP (ICING UP) OR FREQUENT COMPRESSOR CYCLING
- 1.) SYMPTOM: THE A/C WORKS WELL AT FIRST, THEN QUILTS COOLING. THE AIR FLOW FROM THE VENTS IS LOW AND THE COMPRESSOR CLUTCH CYCLES INFREQUENTLY.
SOLUTION: THE TEMPERATURE KNOB IS SET TOO COLD, THE EVAPORATOR IS "ICING UP" AND RESTRICTING AIR FLOW. ALLOW THE ICE TO MELT BY TURNING THE TEMPERATURE KNOB TO THE LEFT (WARMER) IN INCREMENTS OF 10% UNTIL SYMPTOMS DIMINISH.
 - 2.) SYMPTOM: A/C NEVER GETS COLD AND THE COMPRESSOR CLUTCH CYCLES FREQUENTLY.
SOLUTION: THE TEMPERATURE KNOB IS SET TOO WARM. ADJUST THE TEMPERATURE KNOB TO THE RIGHT (COLDER) IN INCREMENTS OF 10% UNTIL THE COMPRESSOR CLUTCH CYCLES INFREQUENTLY.



STREAMLINE 3 KNOB CONTROL PANEL

CONTROL PANEL PACKING LIST

**CONTROL PANEL
491210-RUA**

No.	QTY.	PART No.	DESCRIPTION
1.	1	491209-RUA	STREAMLINE 3 KNOB CONTROL PANEL
2.	1	232007-VUR	GEN IV UNIVERSAL CONTROL HARNESS (TYPE C)

CHECKED BY: _____
 PACKED BY: _____
 DATE: _____

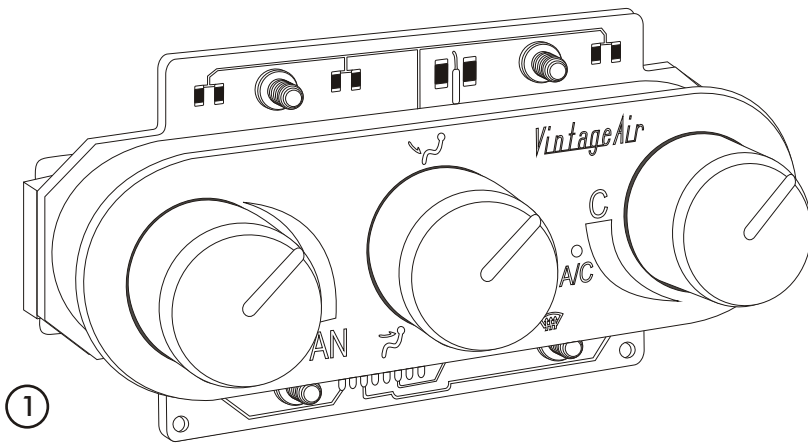

①

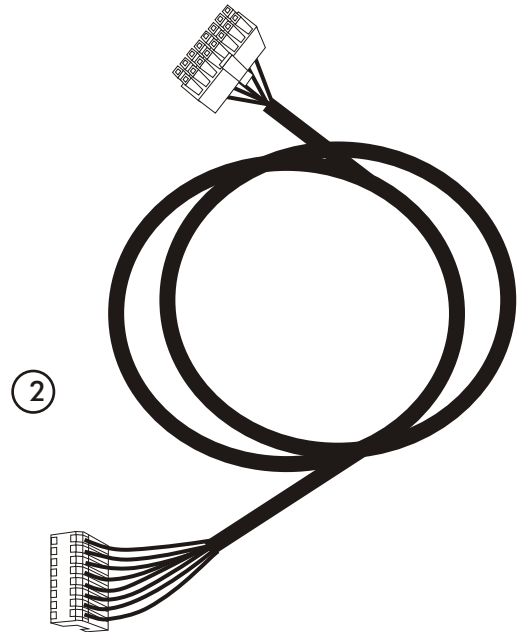

②