



*10305 IH 35 N*SAN ANTONIO*TEXAS 78233*PH 210 654-7171

INSTALLATION INSTRUCTIONS

BEHIND SEAT UNIT

(62300VUY)

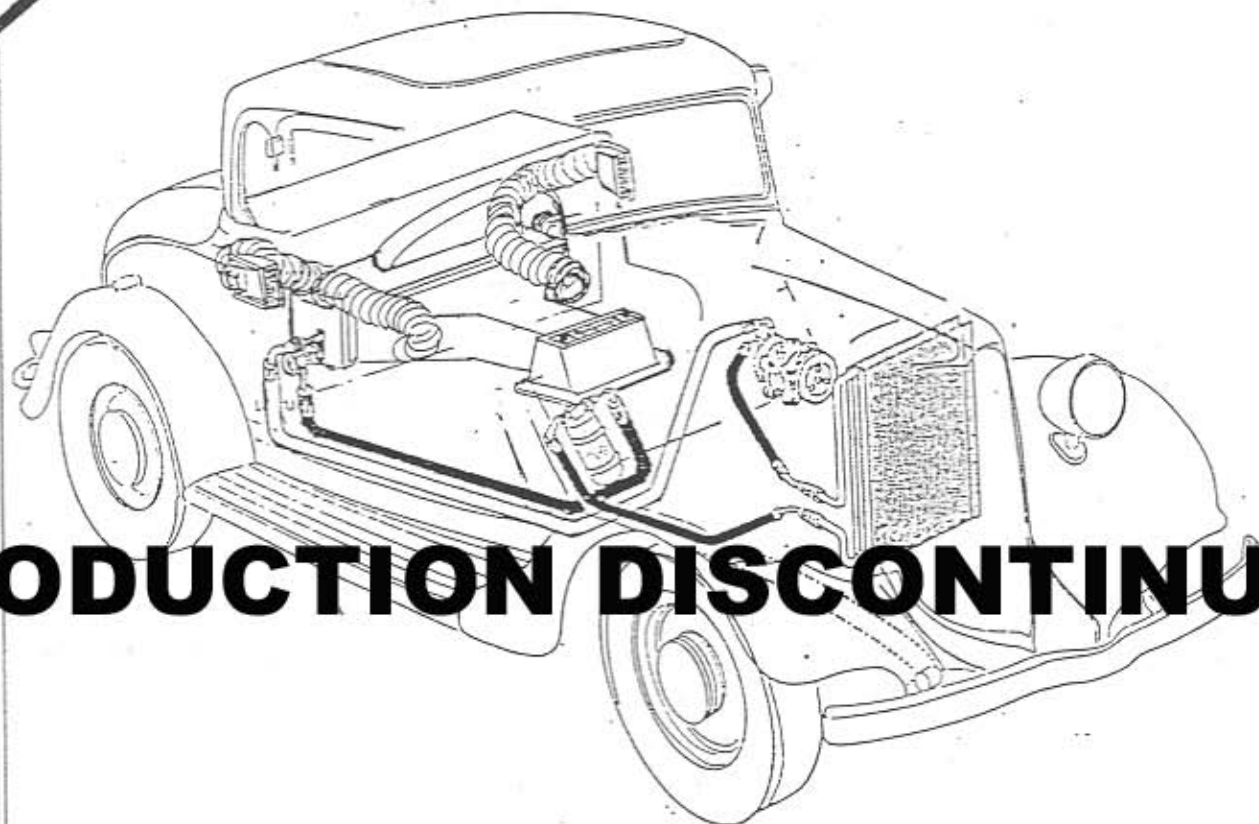

PRODUCTION DISCONTINUED

REFRIDGERATION CAPACITIES: R-134a 1.8 lbs.
R-12 2.0 lbs.

LUBRICANT CAPACITIES: NEW COMPRESSOR - NO ADDITIONAL OIL NEEDED
USED COMPRESSOR - CONSULT VINTAGE AIR

INSTALLATION INSTRUCTIONS FOR
BEHIND SEAT UNIT

MOUNTING: This is a universal unit, produced to fit your special needs. It is made to have the ability to cool your car with the versatility of being mounted almost anywhere. However please keep these points in mind when installing your Vintage air (Air conditioner).

1. Remove seat and insulate car.
2. Use all brackets to insure solid mounting.
3. Make sure unit case is level to ground to insure proper drainage of the condensation out of the unit.
4. Make holes and install louvers as Figure 2 shows. (keep louver hoses as short and straight as possible for best cooling results).
5. Have a panel between the passenger compartment and trunk for best cooling results. (make hole in panel for return air grille installation according with measurements on Figure 1).
6. Make sure all hoses are protected when going thru or near floorboard, firewall, etc, So they won't wear or be cut.

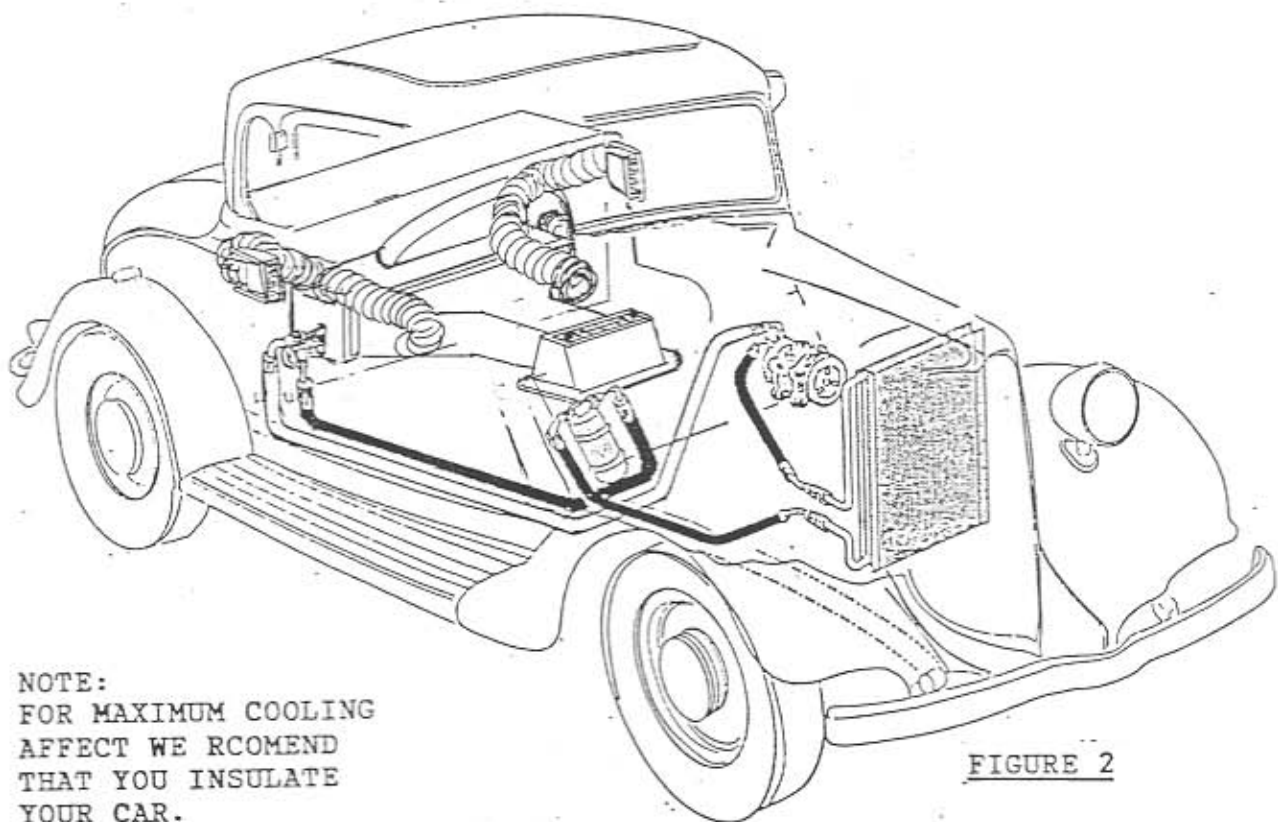

FIGURE 2

NOTE:
FOR MAXIMUM COOLING
EFFECT WE RECOMMEND
THAT YOU INSULATE
YOUR CAR.



REFRIGERATION HOSE ROUTING INSTRUCTIONS

(31300VUD)

Every street rod is a little different depending on the:

- 1) Type of car/engine and location of engine.
- 2) Type of air conditioning equipment used.
- 3) Owners preferences.

There are many other factors that go into making each air conditioner installation different. Usually all of the above decisions are made before any consideration is given to the air conditioner installation. The air conditioner is then installed around everything.

Planning your hose routing:

1. Mount the major components on your car.

- a) The compressor.
- b) The condenser.

c) Evaporator (NOTE: The evaporator is mounted in place for hose routing, but must be removed and placed on a work bench to tighten the evaporator hose fittings.

Two wrenches must be used to tighten the fittings on the evaporator. One on the fitting and one on the counter part fitting attached to the evaporator.)

NOTES:

a) While you are making these lines, determine how they will be held in place (clamps, brackets, etc), you should run them exactly like they will be when finished before you cut them to length.

b) When the hoses are made, remove them and lube all o-rings and fitting seats with refrigeration oil before final tightening.

c) Have a professional air conditioning technician leak-check and service your air conditioner.

d) It is a good idea to leave the radiator shell off until the system is leak-checked in case resealing is necessary.

2. After all the components are mounted, remove the hose cover from the evaporator unit. Push the 5/16" hose onto fitting (3) and screw it loosely to the expansion valve. Push the 1/2" hose onto fitting (13) and screw it loosely to the large threaded fittings coming out of the evaporator.

3. At this time, try to determine where you want your lines to go thru the firewall. Move the hoses to that point. Hold the fittings (6) and (14) up to their respective hoses and determine if the hose will conform to the location for the bulkhead fittings (1) and (2) or bulkhead plate. (Vintage Air Part #01330-VUQ). The 1/2" hose is hard to bend at a sharp angle and the fittings take up a certain amount of space. So before you drill holes in your firewall make sure that you can make the hoses fit what you have planned. The engine compartment appearance is a consideration when choosing this location.

WHEN YOU HAVE DECIDED WHERE YOU WANT TO PLACE YOUR BULKHEAD FITTINGS:

4. Mark these points with a grease pencil and make a template from the inside locating where the holes will be cut. With this template, locate the same points on the outside of the firewall. Mark these points with a grease pencil.

5. With fitting (1) location determined, hold fitting (6) to the drier to determine the best location for the drier that will allow adequate room for the hose and fittings that connect the drier to the bulkhead fitting.

6. Mount the drier. (Keep the drier capped as much as possible, if you must screw the fitting to the drier, tape it closed.)

NOTE: The drier is usually mounted wherever you have room for it. Just remember to mount it in the coolest spot possible and vertically so the sight glass is directly on top. (Not next to the exhaust manifold). Inside the car is okay!

7. If all looks okay, at this point, cut holes for bulkhead fittings and install them.

• 10305 I.H. 35H. • SAN ANTONIO • TEXAS 78233 • PH 210-654-7171

AIR CONDITIONER
EVAPORATOR

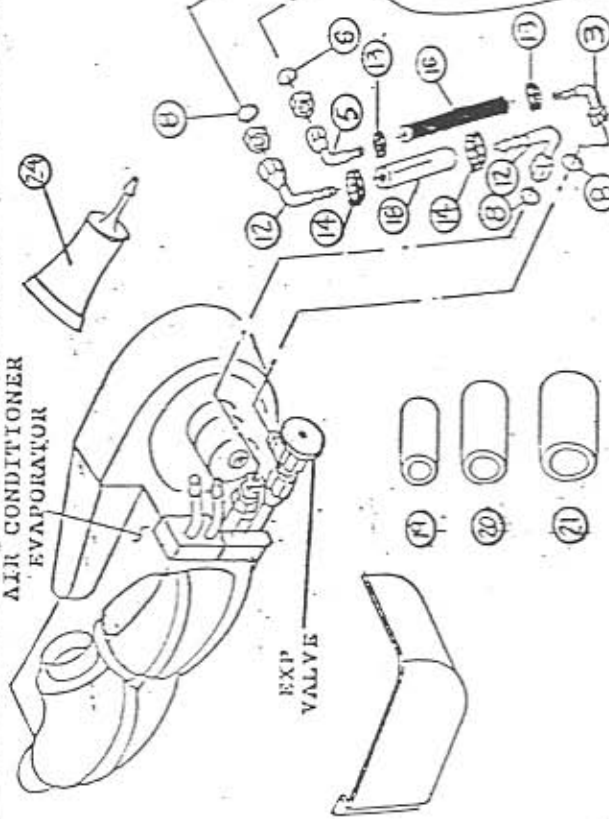

HOSE ROUTING ILLUSTRATION WITH STANDARD DRIER (31300-VUD)

FOR R-12 SANDEN 04508 COMPRESSOR
WITH O-RING CONNECTIONS

NOTE:
OPTIONAL
BULKHEAD
PLATE
AVAILABLE

WHITE HOSE INDICATES
LOW-PRESSURE
BLACK HOSE INDICATES
HIGH-PRESSURE

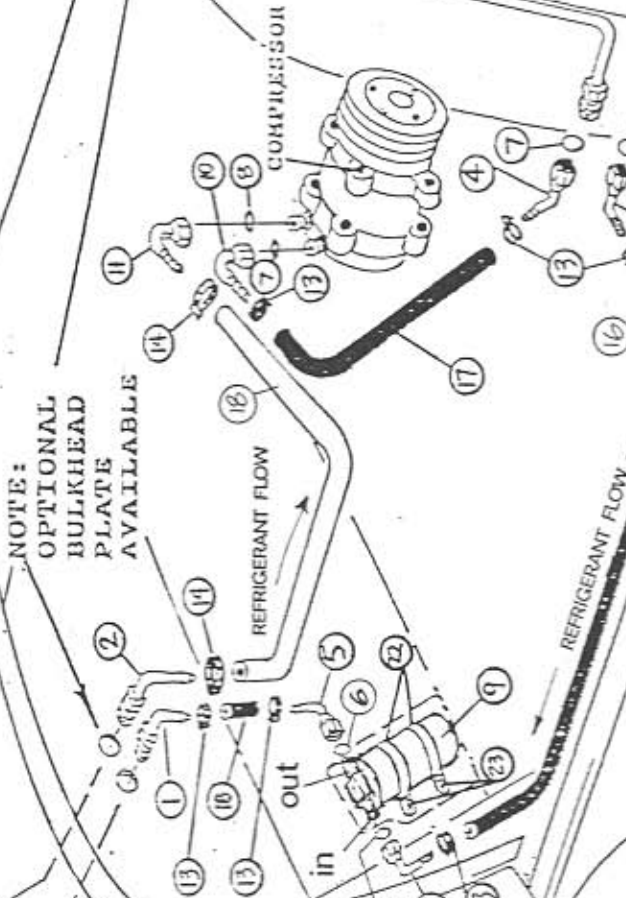

**Important Notice
PLEASE READ**

This Hose Kit Contains
Crimp Ferrule Fittings.
Fittings Must Be Crimped
With R-12 Crimping Tool.

NO	QTY	PART NUMBER	DESCRIPTION
1	1	34231-VUG	#6 90 O-RING BULKHEAD
2	1	34233-VUG	#10 90 O-RING BULKHEAD
3	2	34421-VUG	#6 45 FEMALE O-RING
4	1	34422-VUG	#8 45 FEMALE O-RING
5	3	34431-VUG	#6 90 FEMALE O-RING
6	5	33857-VUF	#6 O-RING
7	2	33858-VUF	#8 O-RING
8	3	33859-VUF	#10 O-RING
9	1	07321-VUC	DRIER
10	1	34442-VUG	#8 135 FEMALE O-RING
11	1	34443-VUG	#10 135 FEMALE O-RING
12	2	34433-VUG	#10 90 FEMALE O-RING
13	8	31603-VUA	#6 & #8 HOSE CLAMP
14	4	31604-VUA	#10 & #12 HOSE CLAMP
15	2	18247-VUB	#8 x 1/2" SHEETMETAL SCREW
16	72"	31854-VUD	#6 x 5/16" REF. HOSE
17	48"	31855-VUD	#8 x 13/32" REF. HOSE
18	60"	31856-VUD	#10 x 1/2" REF. HOSE
19	6	35453-VUG	#5 FERRULE
20	2	35455-VUG	#8 FERRULE
21	4	35456-VUG	#10 FERRULE
22	2	07113-VUB	DRIER CLAMPS
23	2	18247-VUB	#10 SHEETMETAL SCREW
24	1	41116-VUP	TUBE of OIL

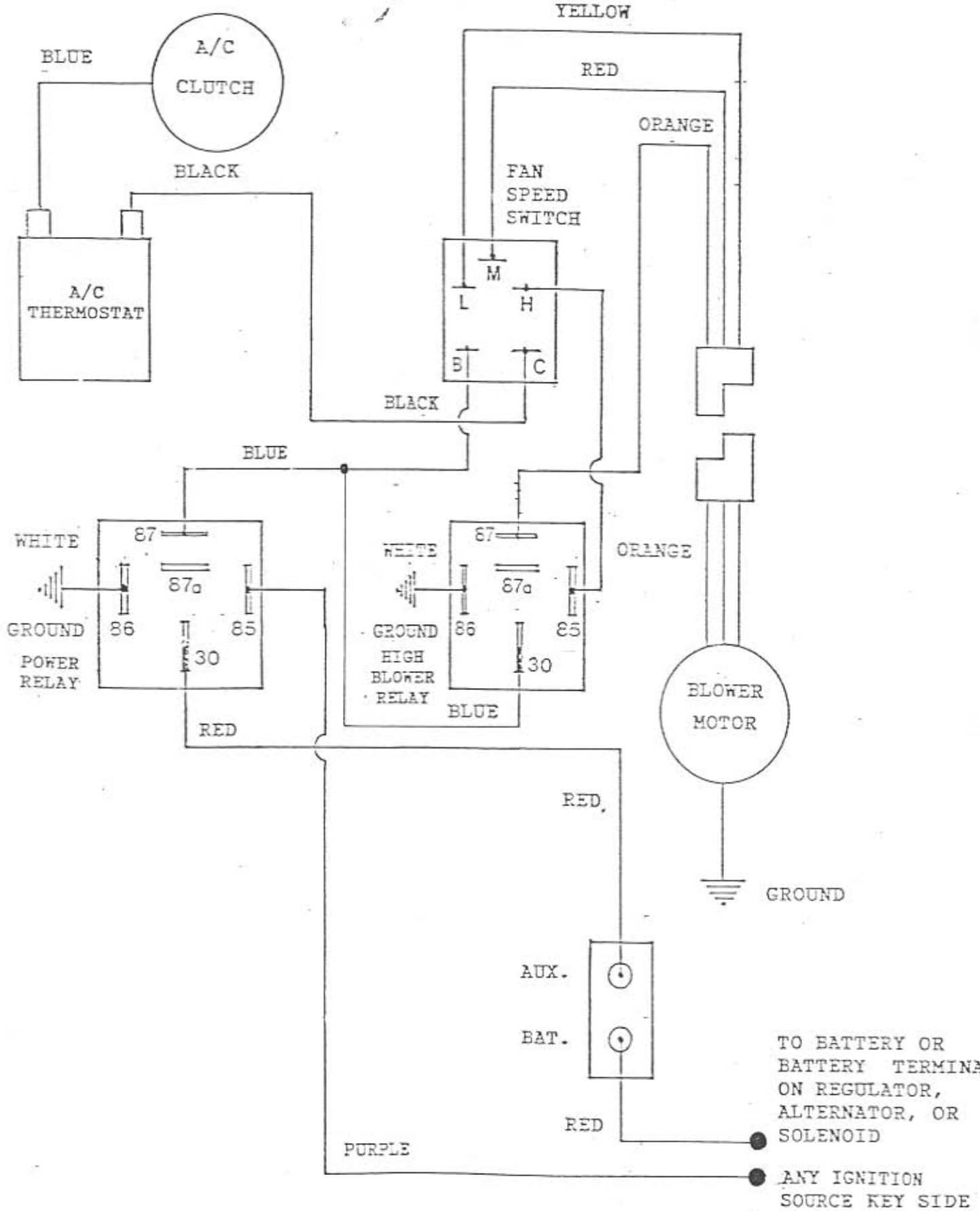



D.O.# _____

Behind Seat Unit Cool
PACKING LIST

- | | | |
|--------------------------------|------------|-------|
| 1- Evaporator with blower | #62300-VUY | _____ |
| 1- Air plenum top | #62520-VUE | _____ |
| 1- Air plenum bottom | #62521-VUE | _____ |
| 1- Control pod with wiring | #49144-VUY | _____ |
| 1- Drain kit (Super Cool only) | #63326-VUE | _____ |
| 1- 2-1/2" X 10' duct hose | #06250-VUE | _____ |
| 2- Pair mount brackets | #64143-VUE | _____ |
| OTHER | # | _____ |

DATE _____

CHECKED: _____

PACKED: _____