

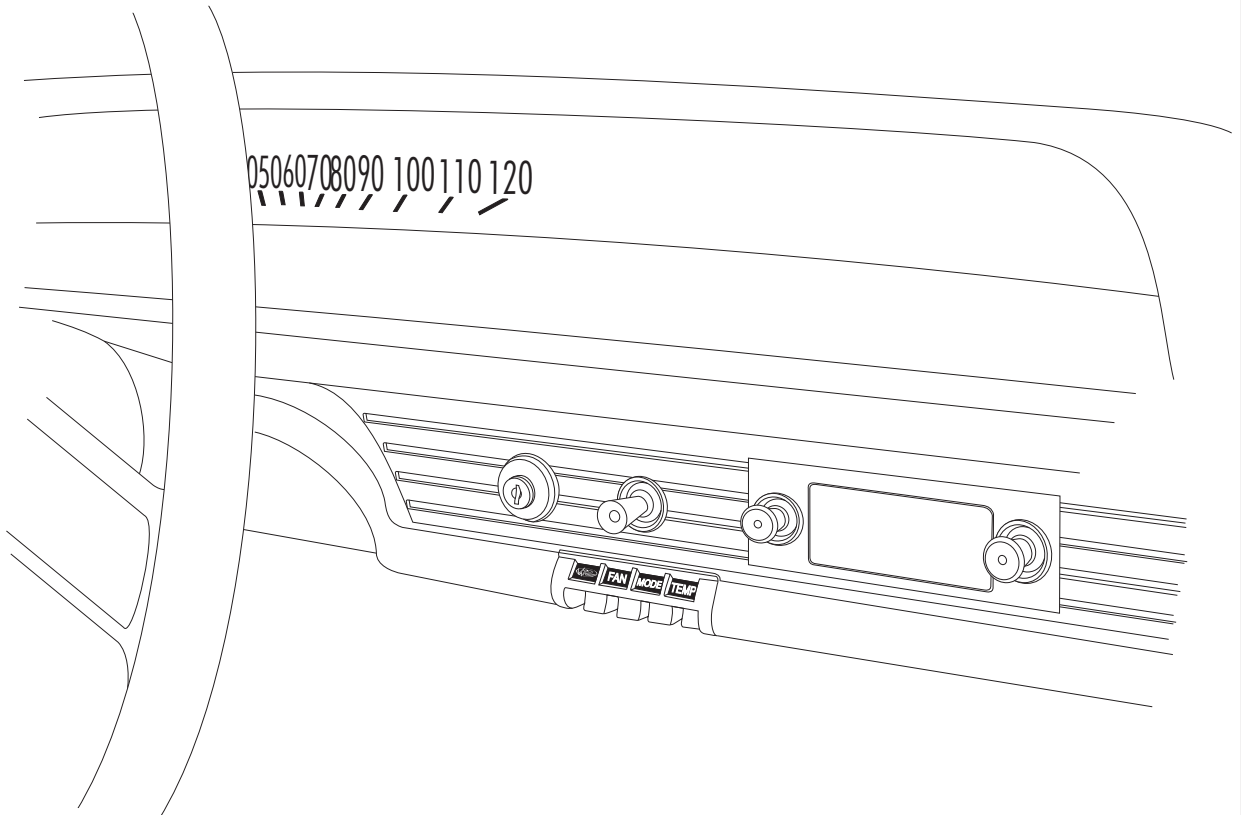

# 1963 IMPALA

CONTROL PANEL  
CONVERSION KIT  
471063



18865 GOLL ST. - SAN ANTONIO, TX. - 78266 ph.210-654-7171 - fax 210-654-3113



## Table of Contents

### PAGES

1. COVER
2. TABLE OF CONTENTS
3. PACKING LIST/ PARTS DISCLAIMER
4. REMOVING OEM CONTROL PANEL & MODE LABEL INSTALLATION  
FIGURES 1, 2, 2a, 2b, 2C
5. CABLE CONVERTER ASSEMBLY MODIFICATIONS & CABLE CONVERTER  
ASSEMBLY MOUNTING CLAMP INSTALLATION  
FIGURES 3 & 4
6. FAN CABLE CONVERTER ASM INSTALLATION & CONTROL HARNESS  
FIGURES 5 & 6
7. CONTROL HARNESS CONT. & MODE CABLE CONVERTER ASM INSTALLATION  
FIGURES 7 & 8
8. CONTROL HARNESS & CONTROL HARNESS CONT.  
FIGURES 9 & 10
9. TEMP CABLE CONVERTER ASM INSTALLATION & CONTROL HARNESS  
FIGURES 11 & 12
10. CONTROL HARNESS CONT. & CONTROL HARNESS FINAL STEP  
FIGURES 13 & 14
11. FINAL STEP & FINAL STEPS CONT.  
FIGURE 15 & 16
12. CONTROL PANEL CALIBRATION PROCEDURE
13. WIRING DIAGRAM
14. OPERATION OF CONTROLS
15. CONTROL PANEL KIT PACKING LIST



**CONTROL KIT PACKING LIST**

**CONTROL KIT  
471063**

No.	QTY.	PART No.	DESCRIPTION
1.	3	112002-SUA	CABLE CONVERTER ASM
2.	1	232006-VUR	GEN IV UNIVERSAL CONTROL HARNESS (TYPE B)
3.	3	65976-VUE	3/16" PUSH-ON RING
4.	3	491010-VUR	CABLE CONVERTER CLAMP
5.	5	21301-VUP	4" TIE WRAP
6.	1	231520	GROUND WIRE
7.	1	484063	63-64 IMPALA CONTROL PANEL MODE LABEL

**\*\* BEFORE BEGINNING INSTALLATION OPEN ALL PACKAGES AND CHECK CONTENTS OF SHIPMENT. PLEASE REPORT ANY SHORTAGES DIRECTLY TO VINTAGE AIR WITHIN 15 DAYS. AFTER 15 DAYS, VINTAGE AIR WILL NOT BE RESPONSIBLE FOR MISSING OR DAMAGED ITEMS.**

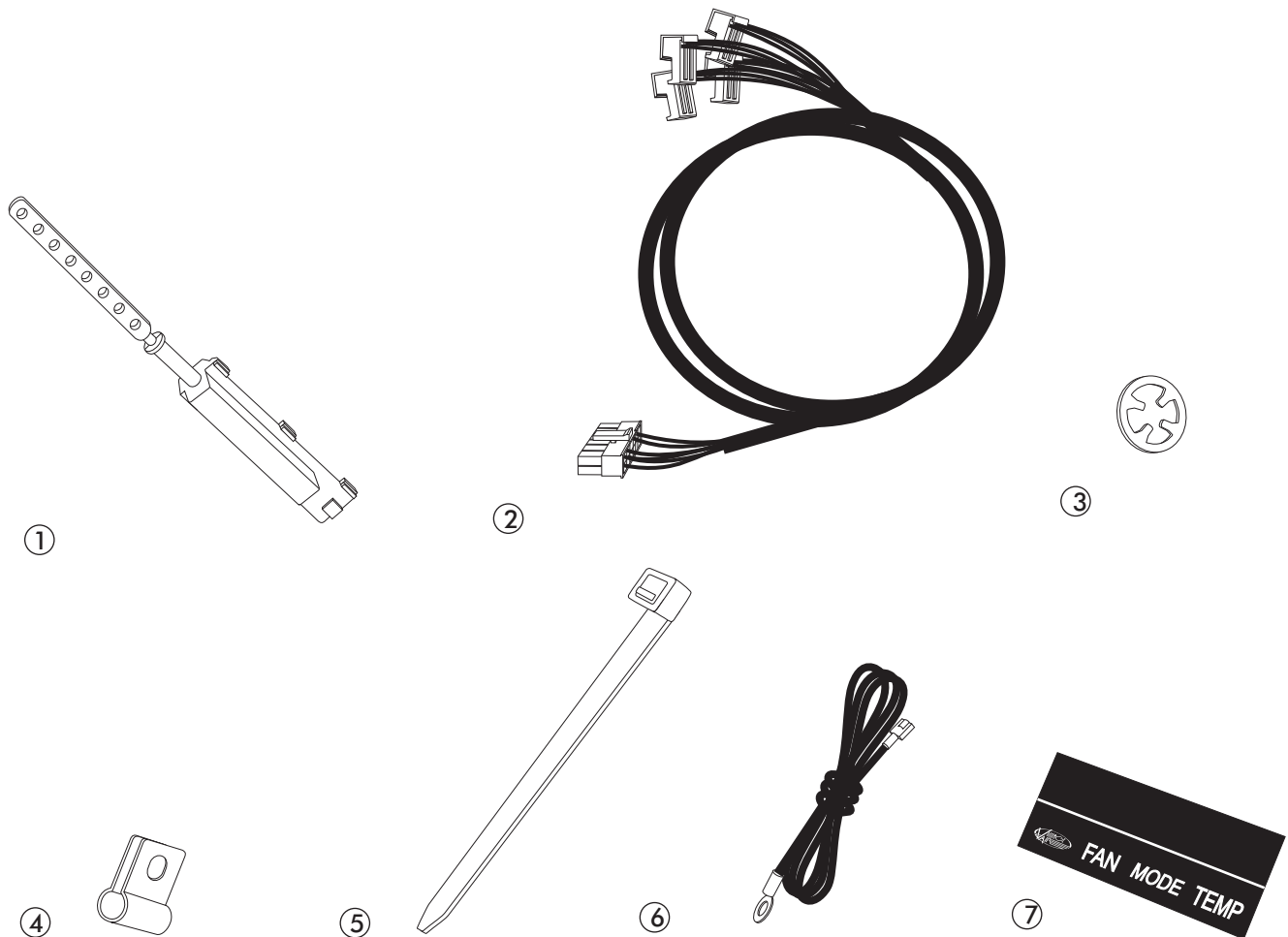

**NOTE: IMAGES MAY NOT DEPICT ACTUAL PARTS AND QUANTITIES. REFER TO PACKING LIST FOR ACTUAL PARTS AND QUANTITIES.**



## CONTROL PANEL CONVERSION INSTRUCTIONS FOR 1963 IMPALA

### REMOVING OEM CONTROL PANEL

- REMOVE THE (2) OEM NUTS FROM CONTROL PANEL FROM UNDER THE DASH.
- DISCONNECT CABLES AND WIRES FROM BACK OF CONTROL PANEL.
- REMOVE THE CONTROL PANEL FROM FRONT OF THE DASH.

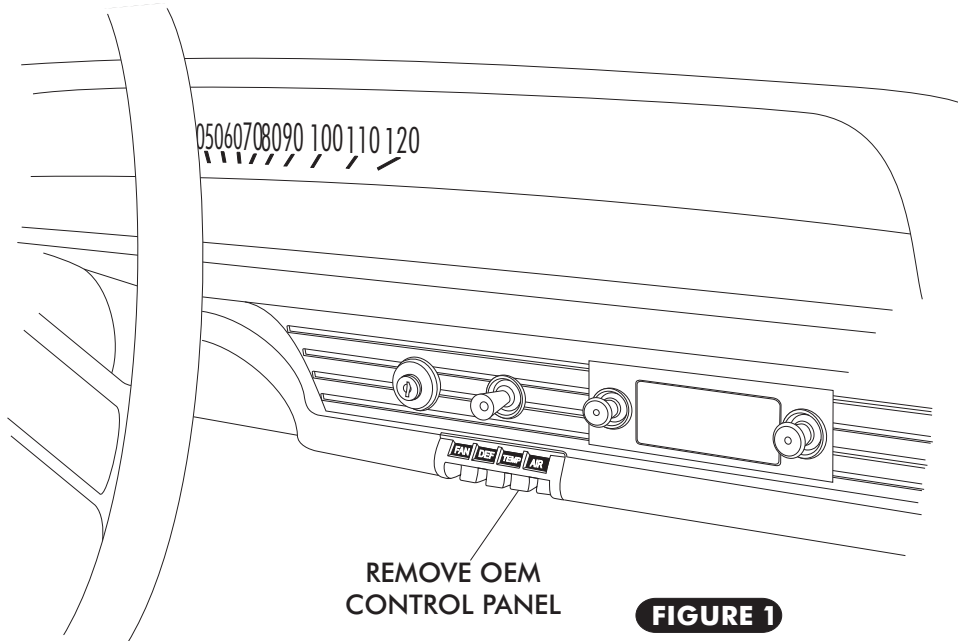

**FIGURE 1**

### MODE LABEL INSTALLATION

- DISASSEMBLE OEM LENS FROM CONTROL PANEL SEE FIGURE 2 BELOW.
- REMOVE 5/16" FROM BACK BRKT AS SHOWN IN FIGURE 2a.
- INSTALL MODE LABEL ON OEM LENS SEE FIGURE 2b.
- INSTALL OEM LENS AND MODE LABEL ON BACK BRKT AS SHOWN IN FIGURE 2b.
- RE-INSTALL OEM LENS AND MODE LABEL ON CONTROL PANEL.

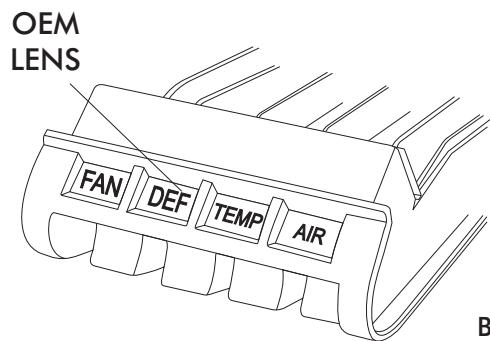

**FIGURE 2**

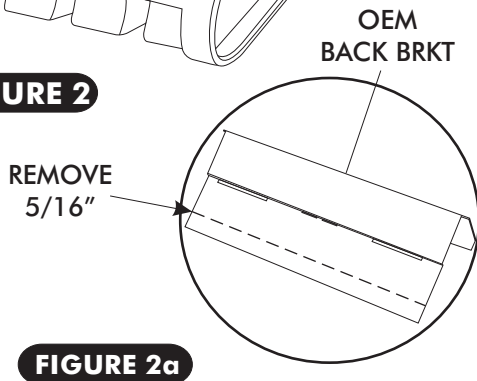

**FIGURE 2a**

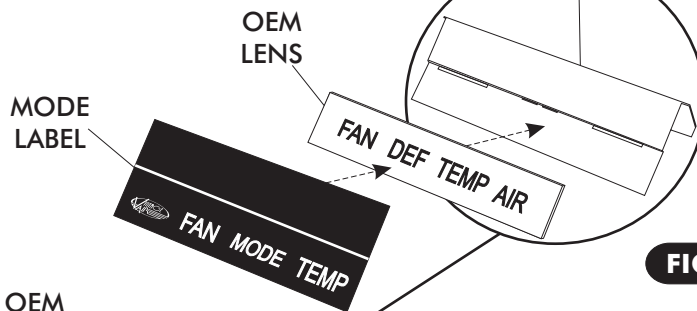

**FIGURE 2b**

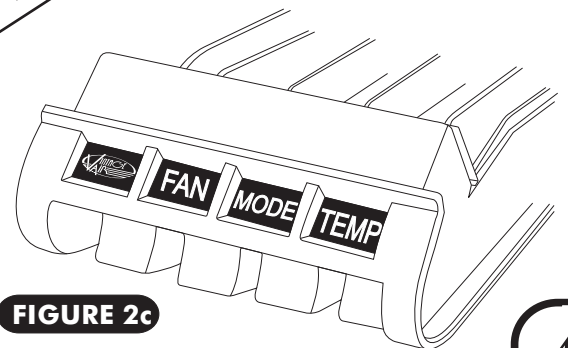
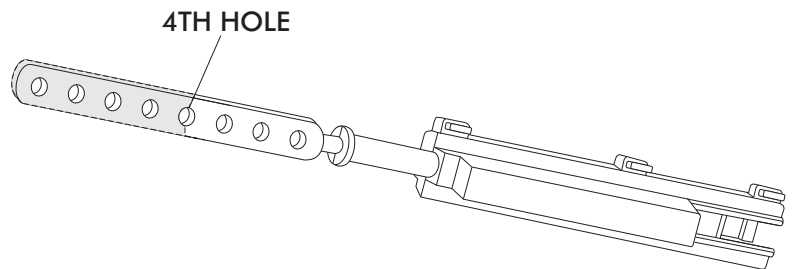
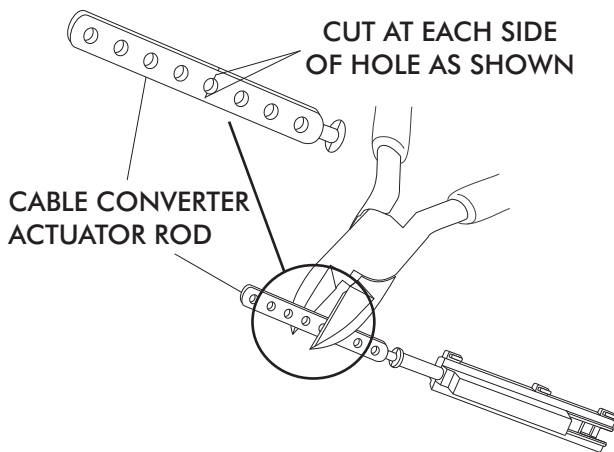

**FIGURE 2c**



**CABLE CONVERTER ASSEMBLY MODIFICATIONS**

- LOCATE THE THREE CABLE CONVERTER ASSEMBLIES, AND USING A PAIR OF WIRE CUTTERS, CUT CABLE CONVERTER ACTUATOR RODS AS SHOWN BELOW IN FIGURE 3.



**CUT ALL THREE CABLE CONVERTER ASSEMBLIES AT 4TH HOLE (REMOVE SHADED PORTION)**

**FIGURE 3**

**CABLE CONVERTER ASSEMBLY MOUNTING CLAMP INSTALLATION**

- INSTALL CABLE CONVERTER ASM MOUNTING CLAMPS. SEE FIGURE 4 BELOW.

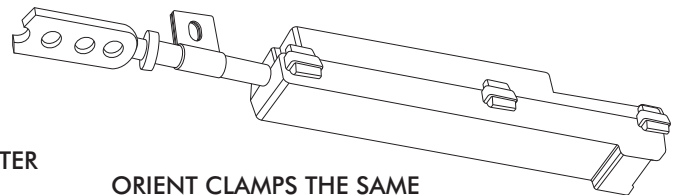
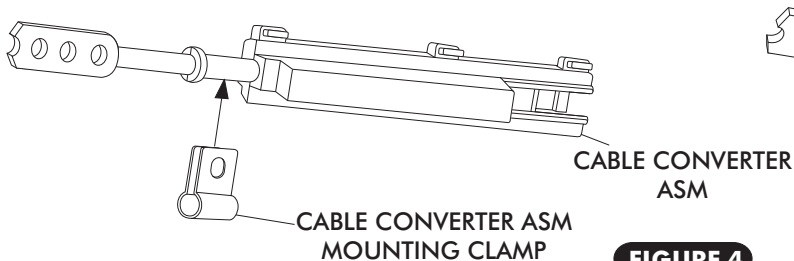

**ORIENT CLAMPS THE SAME DIRECTION FOR ALL (3) CABLE CONVERTER ASSEMBLIES**

**FIGURE 4**

**ORIENT CABLE CONVERTER ASSEMBLIES AS SHOWN AND INSTALL MOUNTING CLAMPS AS SHOWN. (NOTE: ORIENT CLAMPS IN RELATION TO THE (3) HOUSING SNAPS ON CABLE CONVERTER ASSEMBLY)**



## CABLE CONVERTER ASSEMBLY INSTALLATION

### FAN CABLE CONVERTER ASSEMBLY

- INSTALL CABLE CONVERTER ASM ON THE FAN LEVER. SEE FIGURE 5 BELOW.
- INSTALL CABLE CONVERTER LEVER PUSH ROD ONTO OEM CABLE MOUNTING STUD ON LEVER. SEE FIGURE 5 BELOW.
- SECURE THE CABLE CONVERTER ASM TO THE CONTROL PANEL USING THE OEM SCREW IN THE OEM CABLE CLAMP MOUNTING LOCATION. SEE FIGURE 5 BELOW.
- SINCE THE CABLE CONVERTER ASSEMBLY CAN SLIDE BACK AND FORTH IN CLAMP BEFORE SCREW IS TIGHTENED, POSITION CABLE CONVERTER ASSEMBLY SUCH THAT THE FLAT PART OF THE ROD IS AS CLOSE TO FLUSH AS POSSIBLE WITH THE END OF HOUSING AT THE LEVER'S INNER MOST POSITION. SEE FIGURE 5 BELOW.
- SECURE CABLE CONVERTER LEVER PUSH ROD ONTO OEM CABLE MOUNTING STUD USING 3/16" PUSH-ON RING AS SHOWN IN FIGURE 5 BELOW.

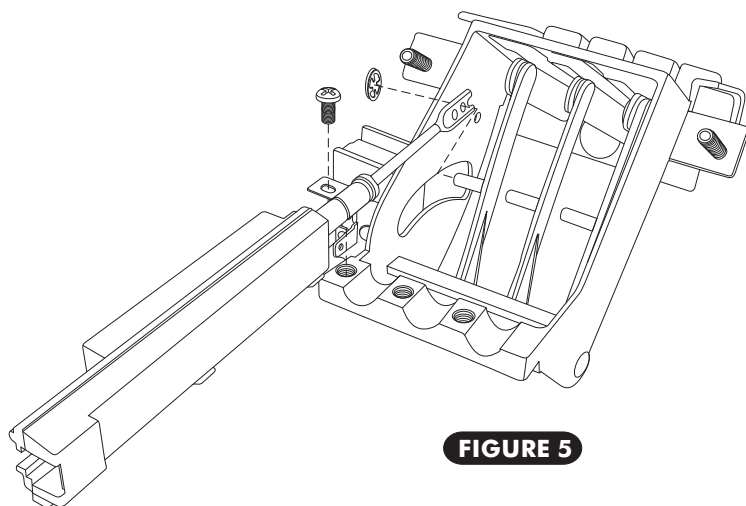

**FIGURE 5**

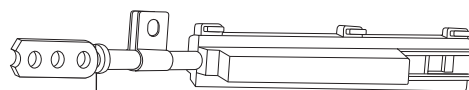

FLUSH  
ROD SHOWN IN APPROX.  
INNER MOST POSITION

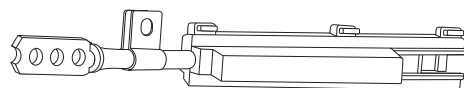

NOTE: DO NOT ALLOW ROD TO  
SEPARATE HOUSING WHEN  
ROD IS IN INNER MOST POSITION.

## CONTROL HARNESS

- LOCATE THE CONTROL PANEL WIRE HARNESS AND PLUG THE CORRESPONDING WIRES INTO THE CORRECT CABLE CONVERTER ASSEMBLY AS SHOWN IN FIGURE 6 BELOW.

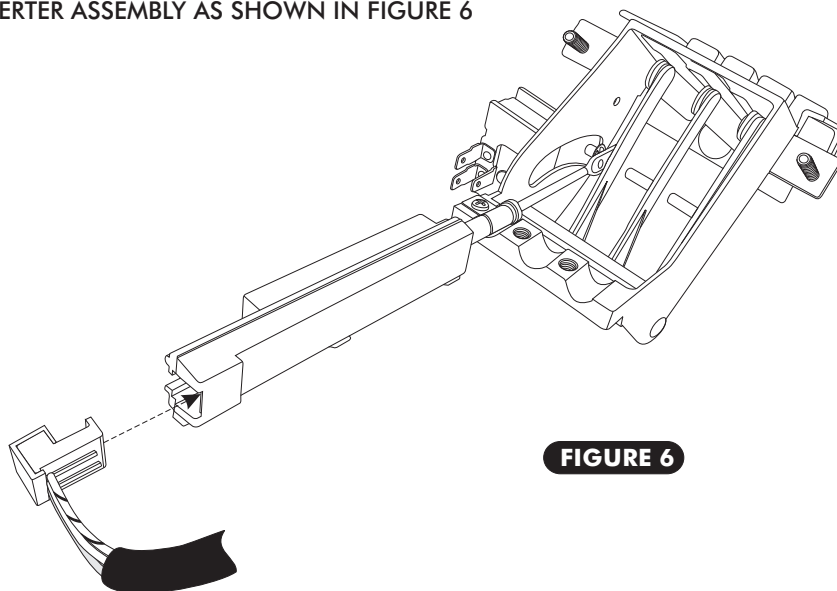

**FIGURE 6**

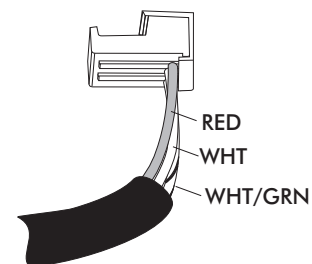

RED  
WHT  
WHT/GRN  
**FAN  
CABLE CONVERTER  
ASSEMBLY**



**CONTROL HARNESS CONT.**

- ONCE WIRES ARE CORRECTLY PLUGGED INTO CABLE CONVERTER ASSEMBLY, SECURE WIRES TO THE CABLE CONVERTER ASSEMBLY USING TIE WRAPS (SUPPLIED). SEE FIGURE 7 BELOW. THE TIE WRAP MUST BE LOCATED BETWEEN THE END OF THE WIRE JACKET AND THE STEP IN THE CABLE CONVERTER HOUSING FORCING A BEND IN EACH WIRE AS THEY PASS OVER THE STEP IN CABLE CONVERTER HOUSING. HEAD OF TIE WRAP MUST FALL ON EDGE OF HOUSING AS SHOWN TO REMAIN TIGHT. ENSURE THAT THE TIE WRAPS ARE SNUG ENOUGH THAT THE WIRES CANNOT MOVE. SEE FIGURE 7.

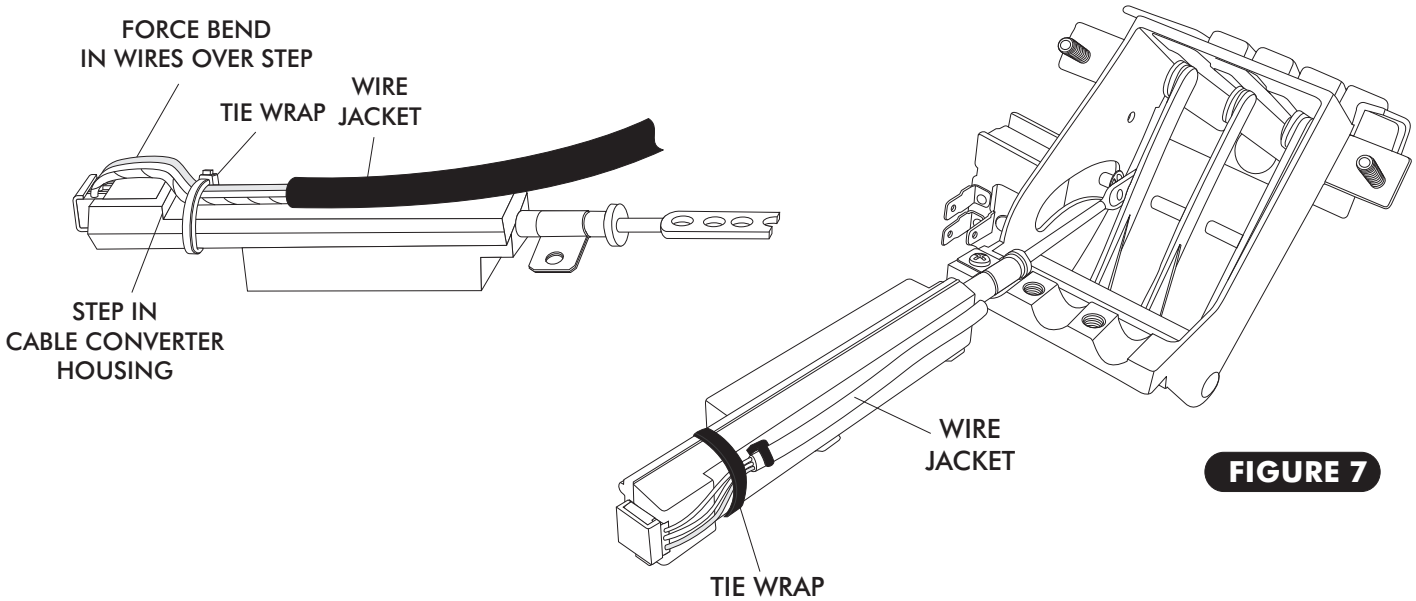
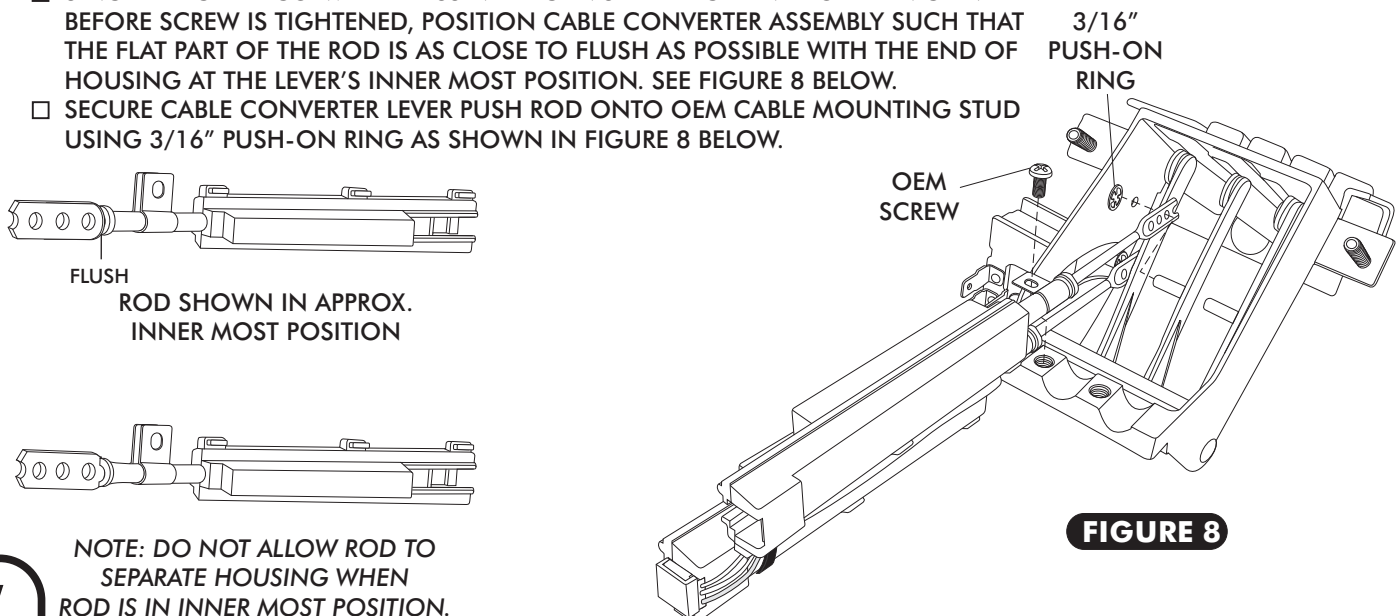

**FIGURE 7**

**CABLE CONVERTER ASSEMBLY INSTALLATION**

**MODE CABLE CONVERTER ASSEMBLY**

- INSTALL CABLE CONVERTER ASM ON THE MODE LEVER. SEE FIGURE 8 BELOW.
- INSTALL CABLE CONVERTER LEVER PUSH ROD ONTO OEM CABLE MOUNTING STUD ON LEVER. SEE FIGURE 8 BELOW.
- SECURE THE CABLE CONVERTER ASM TO THE CONTROL PANEL USING THE OEM SCREW IN THE OEM CABLE CLAMP MOUNTING LOCATION. SEE FIGURE 8 BELOW.
- SINCE THE CABLE CONVERTER ASSEMBLY CAN SLIDE BACK AND FORTH IN CLAMP BEFORE SCREW IS TIGHTENED, POSITION CABLE CONVERTER ASSEMBLY SUCH THAT THE FLAT PART OF THE ROD IS AS CLOSE TO FLUSH AS POSSIBLE WITH THE END OF HOUSING AT THE LEVER'S INNER MOST POSITION. SEE FIGURE 8 BELOW.
- SECURE CABLE CONVERTER LEVER PUSH ROD ONTO OEM CABLE MOUNTING STUD USING 3/16" PUSH-ON RING AS SHOWN IN FIGURE 8 BELOW.



**FIGURE 8**

NOTE: DO NOT ALLOW ROD TO SEPARATE HOUSING WHEN ROD IS IN INNER MOST POSITION.



**CONTROL HARNESS**

- LOCATE THE CONTROL PANEL WIRE HARNESS AND PLUG THE CORRESPONDING WIRES INTO THE CORRECT CABLE CONVERTER ASSEMBLY AS SHOWN IN FIGURE 9 BELOW.

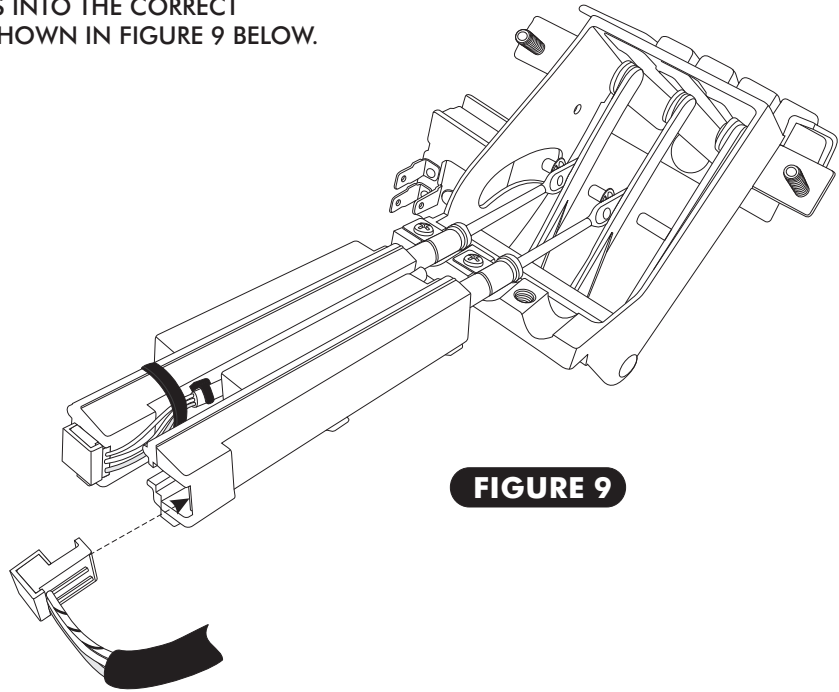
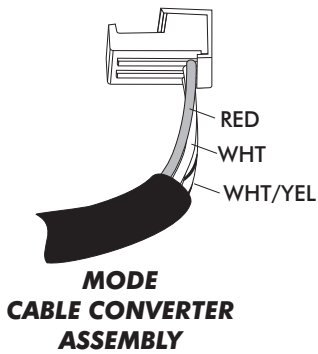

**CONTROL HARNESS CONT.**

- ONCE WIRES ARE CORRECTLY PLUGGED INTO CABLE CONVERTER ASSEMBLY, SECURE WIRES TO THE CABLE CONVERTER ASSEMBLY USING TIE WRAPS (SUPPLIED). SEE FIGURE 10 BELOW. THE TIE WRAP MUST BE LOCATED BETWEEN THE END OF THE WIRE JACKET AND THE STEP IN THE CABLE CONVERTER HOUSING FORCING A BEND IN EACH WIRE AS THEY PASS OVER THE STEP IN CABLE CONVERTER HOUSING. HEAD OF TIE WRAP MUST FALL ON EDGE OF HOUSING AS SHOWN TO REMAIN TIGHT. ENSURE THAT THE TIE WRAPS ARE SNUG ENOUGH THAT THE WIRES CANNOT MOVE. SEE FIGURE 10.

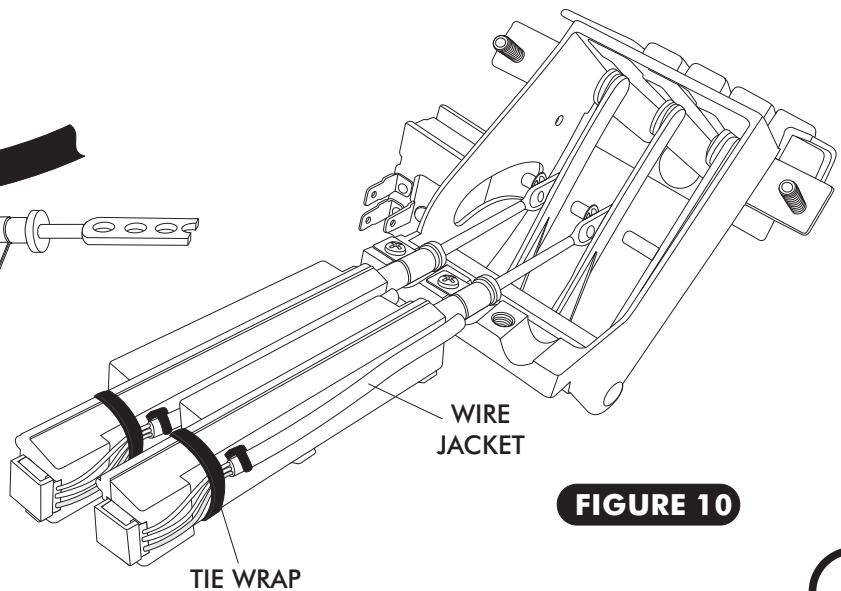
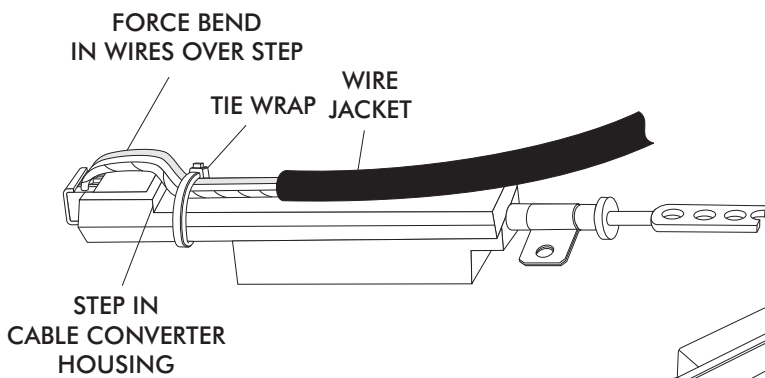



## CABLE CONVERTER ASSEMBLY INSTALLATION

### TEMP CABLE CONVERTER ASSEMBLY

- INSTALL CABLE CONVERTER ASM ON THE TEMP LEVER. SEE FIGURE 11 BELOW.
- INSTALL CABLE CONVERTER LEVER PUSH ROD ONTO OEM CABLE MOUNTING STUD ON LEVER. SEE FIGURE 11 BELOW.
- SECURE THE CABLE CONVERTER ASM TO THE CONTROL PANEL USING THE OEM SCREW IN THE OEM CABLE CLAMP MOUNTING LOCATION. SEE FIGURE 11 BELOW.
- SINCE THE CABLE CONVERTER ASSEMBLY CAN SLIDE BACK AND FORTH IN CLAMP BEFORE SCREW IS TIGHTENED, POSITION CABLE CONVERTER ASSEMBLY SUCH THAT THE FLAT PART OF THE ROD IS AS CLOSE TO FLUSH AS POSSIBLE WITH THE END OF HOUSING AT THE LEVER'S INNER MOST POSITION. SEE FIGURE 11 BELOW.
- SECURE CABLE CONVERTER LEVER PUSH ROD ONTO OEM CABLE MOUNTING STUD USING 3/16" PUSH-ON RING AS SHOWN IN FIGURE 11 BELOW.

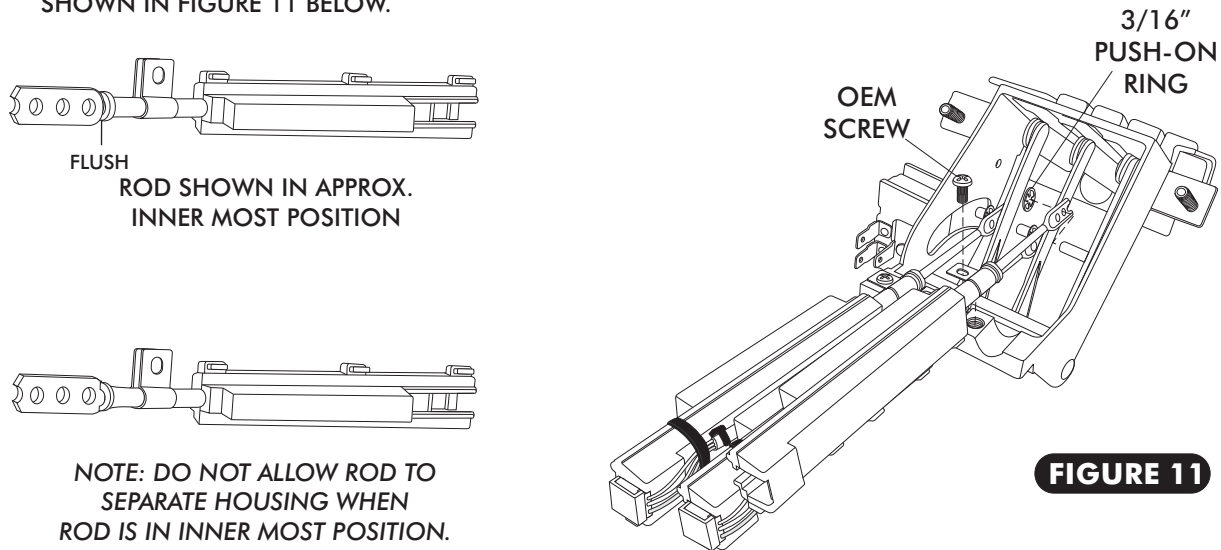
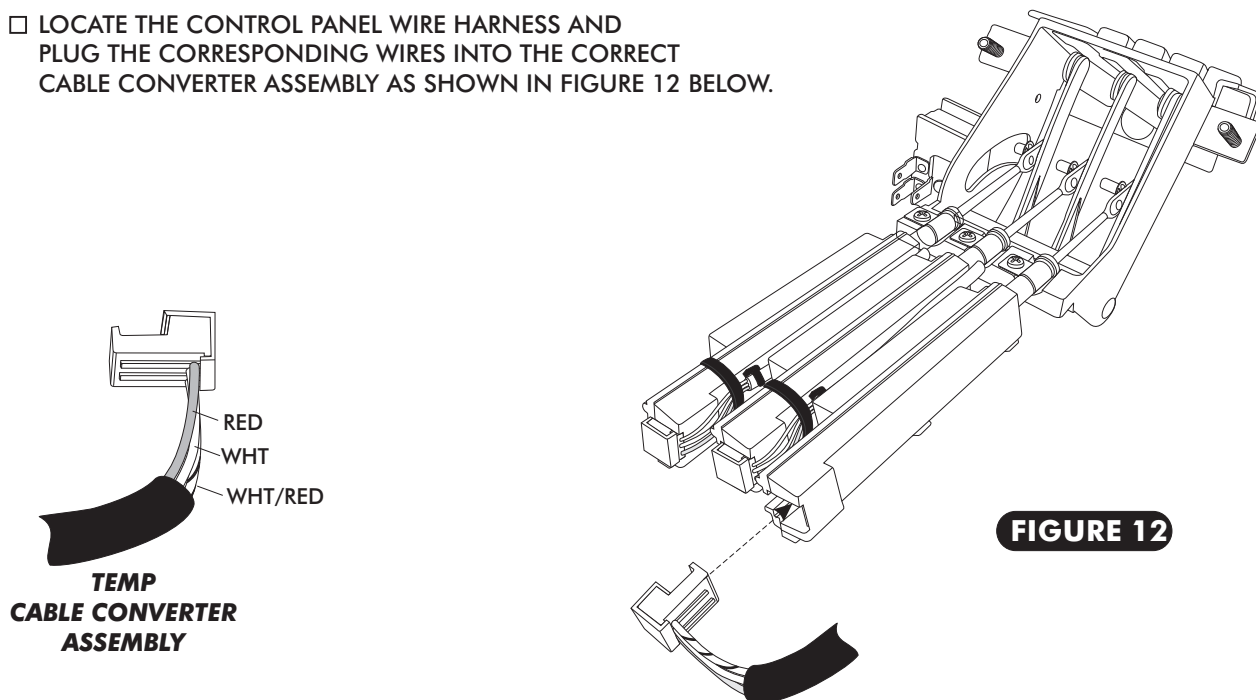

**FIGURE 11**

NOTE: DO NOT ALLOW ROD TO SEPARATE HOUSING WHEN ROD IS IN INNER MOST POSITION.

### CONTROL HARNESS

- LOCATE THE CONTROL PANEL WIRE HARNESS AND PLUG THE CORRESPONDING WIRES INTO THE CORRECT CABLE CONVERTER ASSEMBLY AS SHOWN IN FIGURE 12 BELOW.

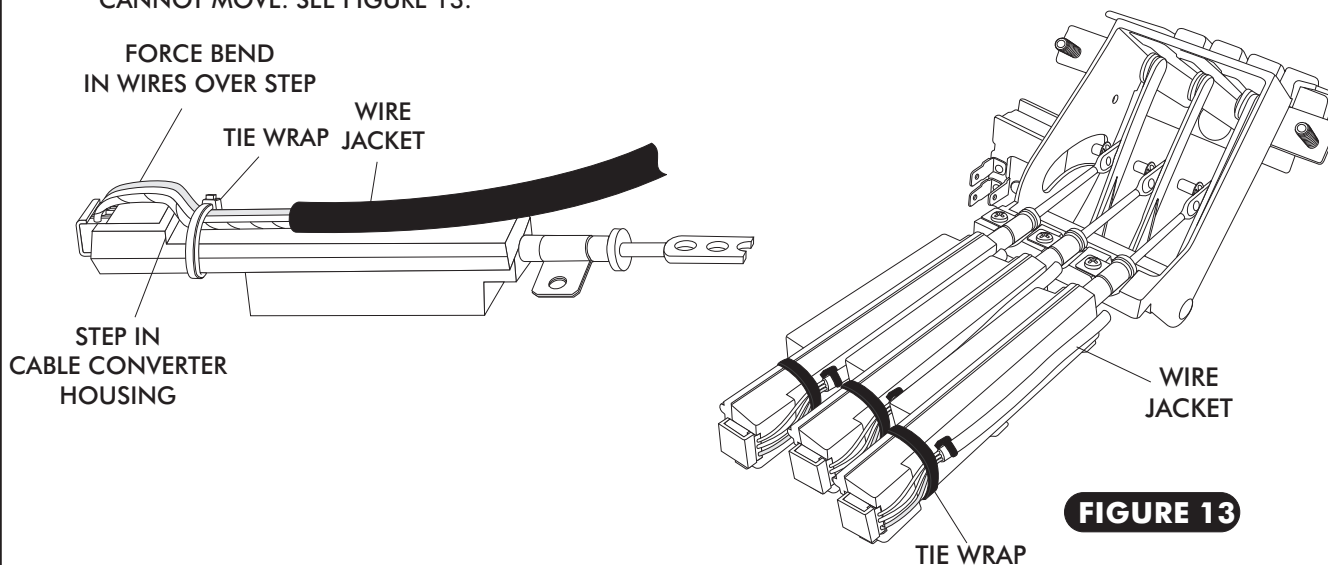

**FIGURE 12**



**CONTROL HARNESS CONT.**

- ONCE WIRES ARE CORRECTLY PLUGGED INTO CABLE CONVERTER ASSEMBLY, SECURE WIRES TO THE CABLE CONVERTER ASSEMBLY USING TIE WRAPS (SUPPLIED). SEE FIGURE 13 BELOW. THE TIE WRAP MUST BE LOCATED BETWEEN THE END OF THE WIRE JACKET AND THE STEP IN THE CABLE CONVERTER HOUSING FORCING A BEND IN EACH WIRE AS THEY PASS OVER THE STEP IN CABLE CONVERTER HOUSING. HEAD OF TIE WRAP MUST FALL ON EDGE OF HOUSING AS SHOWN TO REMAIN TIGHT. ENSURE THAT THE TIE WRAPS ARE SNUG ENOUGH THAT THE WIRES CANNOT MOVE. SEE FIGURE 13.

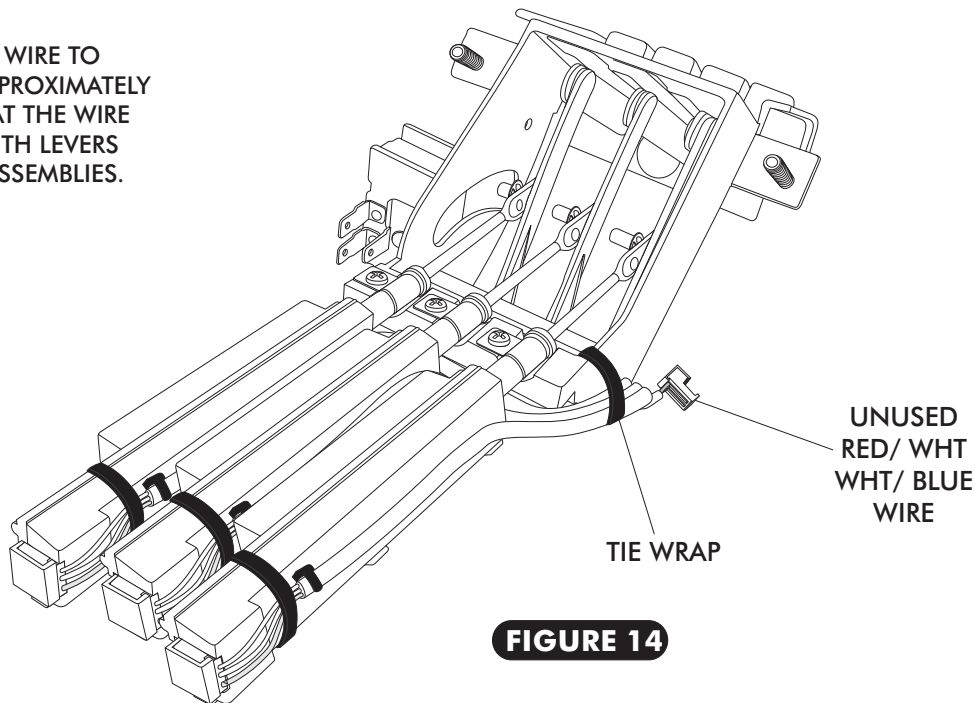

**FIGURE 13**

**CONTROL HARNESS FINAL STEP**

- USING THE SUPPLIED TIE-WRAPS, TIE THE WIRES TO THE CONTROL PANEL AS SHOWN IN FIGURE 14 BELOW. CONFIRM THAT WIRES ARE SECURED AND DO NOT INTERFERE WITH LEVER OPERATION OR CABLE CONVERTER ASSEMBLY.

**NOTE:** TIE THE UNUSED WIRE TO THE CONTROL PANEL APPROXIMATELY AS SHOWN, ENSURE THAT THE WIRE DOES NOT INTERFERE WITH LEVERS OR CABLE CONVERTER ASSEMBLIES.

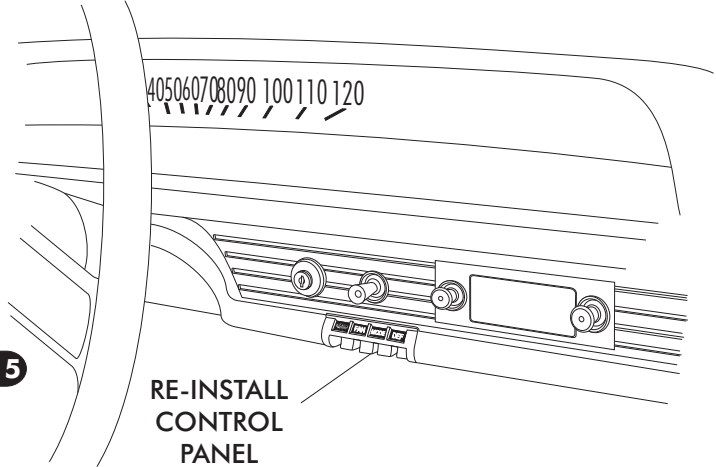
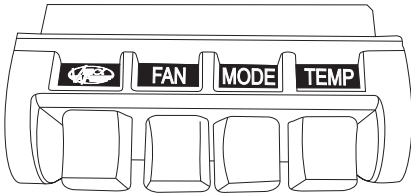

**FIGURE 14**



**FINAL STEPS**

- RE-INSTALL CONTROL PANEL IN DASH USING THE (2) OEM NUTS .



**FIGURE 15**

**FINAL STEPS CONT.**

- PLUG THE WIRING HARNESS INTO THE ECU MODULE ON SUB CASE. SEE FIGURE 16 BELOW.
- WIRE ACCORDING TO WIRING DIAGRAM ON PAGE 13.
- CONTROL PANEL CALIBRATION PROCEDURE AND OPERATION INSTRUCTIONS:
  - CALIBRATING THE CONTROL PANEL WILL SET THE RANGE OF TRAVEL FOR THE CABLE CONVERTERS CONNECTED TO THE OEM CONTROL PANEL LEVERS. PERFORMING THIS PROCEDURE WILL SET THE LIMITS OF THE CABLE CONVERTERS AT THEIR HIGHEST AND LOWEST POINTS
  - LOCATE THE GRAY WIRE WITH AN UNUSED CONNECTOR IN THE WIRING HARNESS NEAR THE TWO CABLE HARNESS RELAYS. THE WIRE IS LABELED PRGM ON THE WIRING DIAGRAM ON PAGE 13.
  - IT WILL BE NECESSARY TO GROUND THE GRAY WIRE FOR APPROXIMATELY FIVE SECONDS WHILE MOVING THE CONTROLS SO IT IS SOMETIMES HELPFUL TO ATTACH ONE END OF THE WHITE JUMPER WIRE TO THE VEHICLE'S GROUND (FOR EXAMPLE THE CHASSIS) AND HAVE THE OTHER END READY TO CONNECT TO THE GRAY PRGM WIRE WHEN THE PROCEDURE REQUIRES IT.
  - TO CALIBRATE THE CONTROL PANEL FOLLOW THE CALIBRATION PROCEDURES ON PAGE 12.

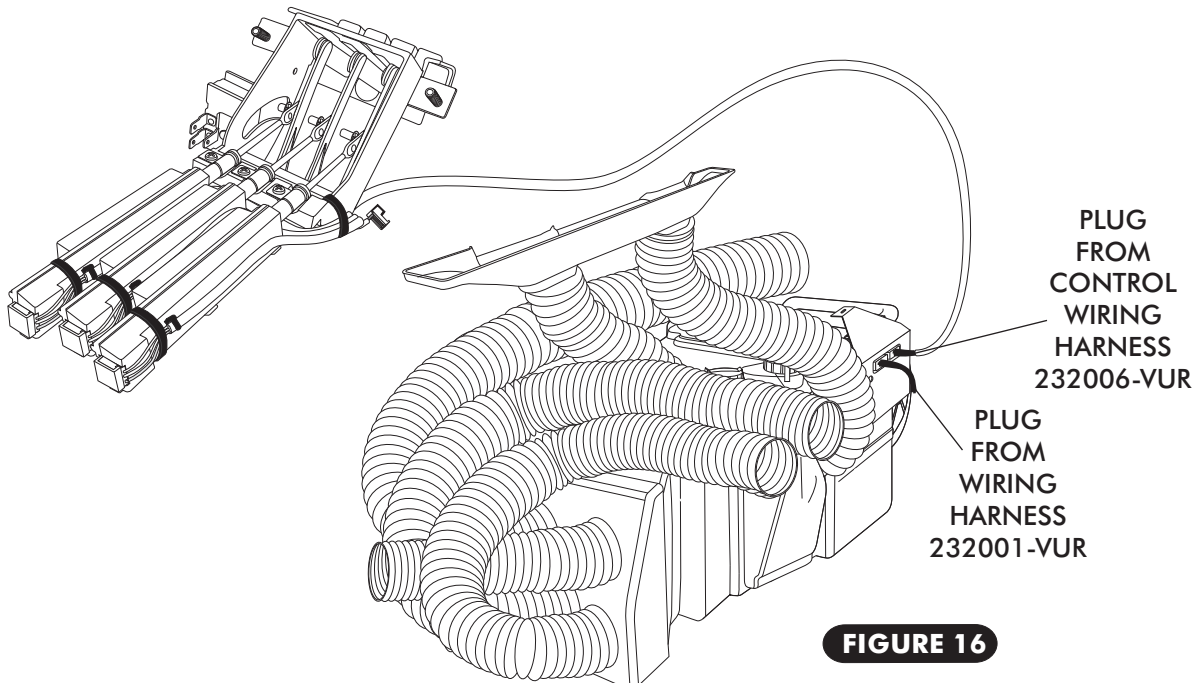
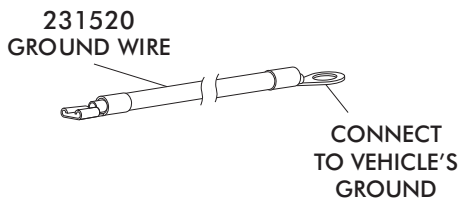

**FIGURE 16**



### CONTROL PANEL CALIBRATION PROCEDURE

1. TURN THE IGNITION SWITCH ON (DO NOT START THE ENGINE)
2. CONNECT THE WHITE JUMPER WIRE TO VEHICLE'S GROUND (FOR EXAMPLE THE VEHICLE CHASSIS). ENSURE THAT THE GRAY WIRE IS NOT GROUNDING. DO NOT CONNECT JUMPER WIRE TO THE GRAY PRGM WIRE.



3. MOVE ALL OF THE CONTROL LEVERS TO THEIR MAXIMUM POSITIONS, AS SHOWN.

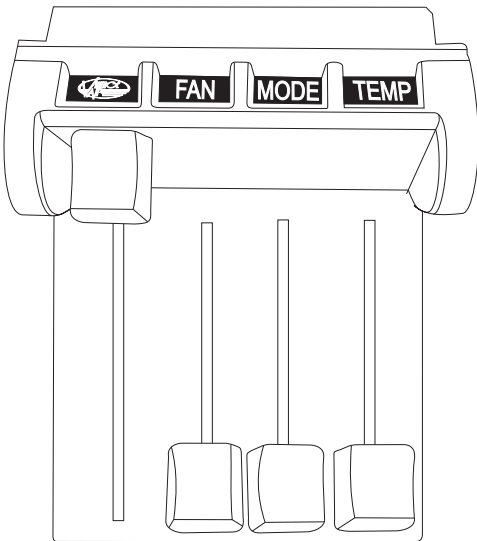

4. GROUND THE GRAY WIRE BY CONNECTING THE GRAY PRGM WIRE & WHITE JUMPER WIRE FOR APPROXIMATELY 5 SECONDS (THE BLOWER WILL CHANGE SPEEDS WHEN STEP FOUR IS COMPLETE)

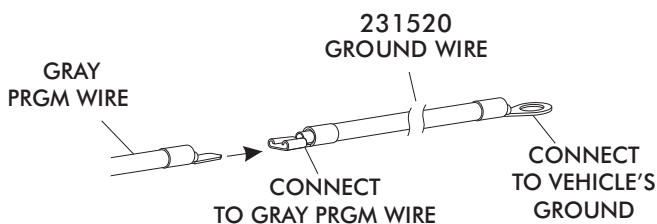

5. LEAVING THE GRAY WIRE GROUNDING, MOVE ALL OF THE CONTROL LEVERS TO THEIR MINIMUM POSITIONS AS SHOWN.

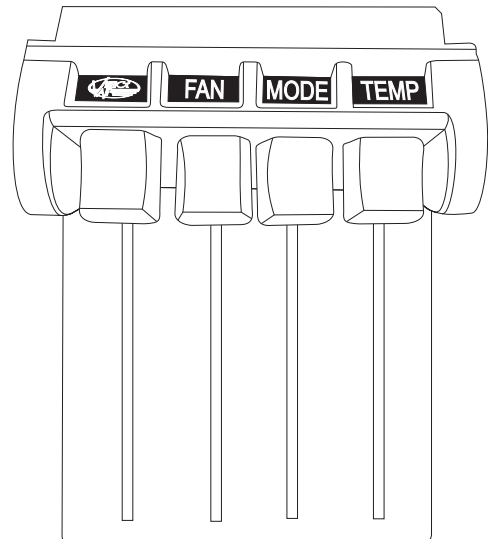

6. DISCONNECT THE GRAY WIRE FROM THE WHITE GROUND JUMPER WIRE (THE BLOWER WILL CHANGE SPEEDS WHEN STEP SIX IS COMPLETE)

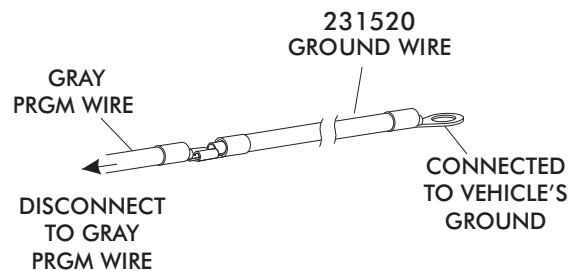

7. START THE ENGINE AND TEST ALL OF THE CONTROLS TO ENSURE THAT THE INTENDED RESULTS WERE ACCOMPLISHED.
8. DISCONNECT THE WHITE JUMPER WIRE FROM VEHICLE'S GROUND.

NOTE: THIS PROCEDURE MAY BE REPEATED IF NECESSARY.

**\* WHEN FINISHED, TAPE OVER PROGRAM WIRE CONNECTOR WITH ELECTRICAL TAPE TO PREVENT ACCIDENTAL CONTACT WITH CHASSIS GROUND.**





## OPERATION OF CONTROLS

**NOTE: CONTROLS MUST BE CALIBRATED PRIOR TO FIRST OPERATION- REFER TO CONTROL PANEL INSTRUCTIONS**

**NOTE: WHEN BATTERY POWER IS FIRST CONNECTED TO THE ECU, THE COMPUTER GOES THROUGH AN INITIALIZATION SEQUENCE. THIS INITIALIZATION MAY TAKE UP TO 30 SECONDS. DURING INITIALIZATION THE BLOWER WILL NOT OPERATE, BUT THE DOORS INSIDE THE UNIT WILL BE OPERATING. A LOW BATTERY OR DISCONNECTING THE BATTERY MAY ALSO TRIGGER A RE-INITIALIZATION. DURING START UP, A LOW BATTERY MAY DROP BELOW 7 VOLTS, TRIGGERING RE-INITIALIZATION.**

**NOTE: ORIGINAL BLOWER SWITCH WILL NOT BE USED.**

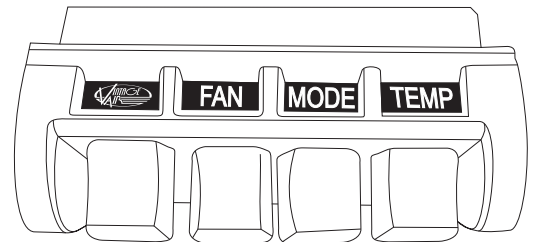

**BLOWER SPEED      MODE LEVER      THERMOSTAT LEVER**

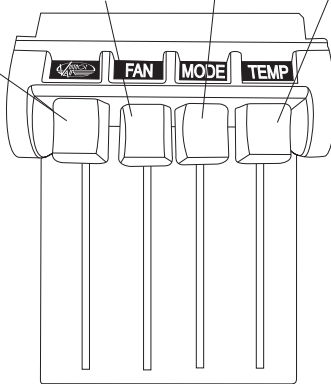

### SYSTEM OFF

**BLOWER SPEED**  
THIS LEVER CONTROLS THE BLOWER SPEED, FROM OFF TO HI

**MODE LEVER**  
THIS LEVER CONTROLS THE MODE POSITIONS FROM DASH TO FLOOR TO DEFROST

**THERMOSTAT LEVER**  
THIS LEVER CONTROLS THE TEMPERATURE FROM HOT TO COLD

**BLOWER SPEED**  
SLIDE THE FAN LEVER UP OR DOWN TO SELECT DESIRE FAN SPEED (SLIDE LEVER ALL THE WAY DOWN FOR MAXIMUM FAN SPEED)

**MODE LEVER**  
SLIDE THE MODE LEVER ALL THE WAY UP FOR DASH MODE

**THERMOSTAT LEVER**  
IN A/C MODE SLIDE THE TEMP LEVER ALL THE WAY UP TO ENGAGE COMPRESSOR FOR MAXIMUM COOLING. (SLIDE LEVER UP OR DOWN TO ADJUST DESIRED TEMPERATURE)

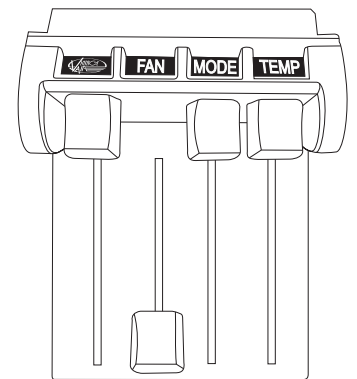

### A/C MODE

**BLOWER SPEED**  
SLIDE THE FAN LEVER UP OR DOWN TO SELECT DESIRE FAN SPEED (SLIDE LEVER ALL THE WAY DOWN FOR MAXIMUM FAN SPEED)

**MODE LEVER**  
SLIDE THE MODE LEVER TO THE CENTER FOR FLOOR MODE (SLIDE LEVER UP OR DOWN TO BLEND BETWEEN DESIRED MODE POSITIONS)

**THERMOSTAT LEVER**  
IN HEAT MODE SLIDE THE TEMP LEVER ALL THE WAY DOWN FOR MAXIMUM HEATING. (SLIDE LEVER UP OR DOWN TO ADJUST DESIRED TEMPERATURE)

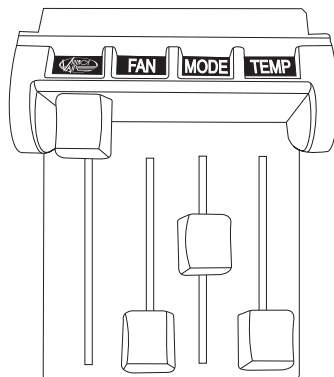

### HEAT MODE

**BLOWER SPEED**  
SLIDE THE FAN LEVER UP OR DOWN TO SELECT DESIRE FAN SPEED (SLIDE LEVER ALL THE WAY DOWN FOR MAXIMUM FAN SPEED)

**MODE LEVER**  
SLIDE THE MODE LEVER ALL THE WAY DOWN FOR DEFROST MODE (SLIDE LEVER UP OR DOWN TO BLEND BETWEEN DESIRED MODE POSITIONS)

**THERMOSTAT LEVER**  
IN DEF MODE SLIDE THE TEMP LEVER ALL THE WAY UP TO ENGAGE COMPRESSOR FOR MAXIMUM COOLING. (SLIDE LEVER UP OR DOWN TO ADJUST DESIRED TEMPERATURE)

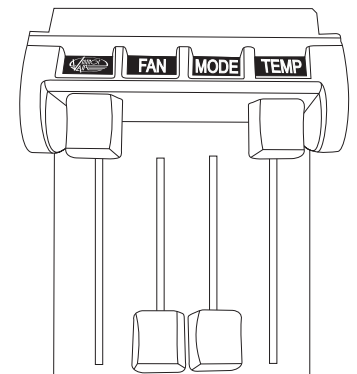

### DEFROST MODE



## CONTROL KIT PACKING LIST

**CONTROL KIT  
471063**

No.	QTY.	PART No.	DESCRIPTION	
1.	3	112002-SUA	CABLE CONVERTER ASM	_____
2.	1	232006-VUR	GEN IV UNIVERSAL CONTROL HARNESS (TYPE B)	_____
3.	3	65976-VUE	3/16" PUSH-ON RING	_____
4.	3	491010-VUR	CABLE CONVERTER CLAMP	_____
5.	5	21301-VUP	4" TIE WRAP	_____
6.	1	231520	GROUND WIRE	_____
7.	1	484063	1963-64 IMPALA CONTROL PANEL MODE LABEL	_____

CHECKED BY: \_\_\_\_\_  
 PACKED BY: \_\_\_\_\_  
 DATE: \_\_\_\_\_

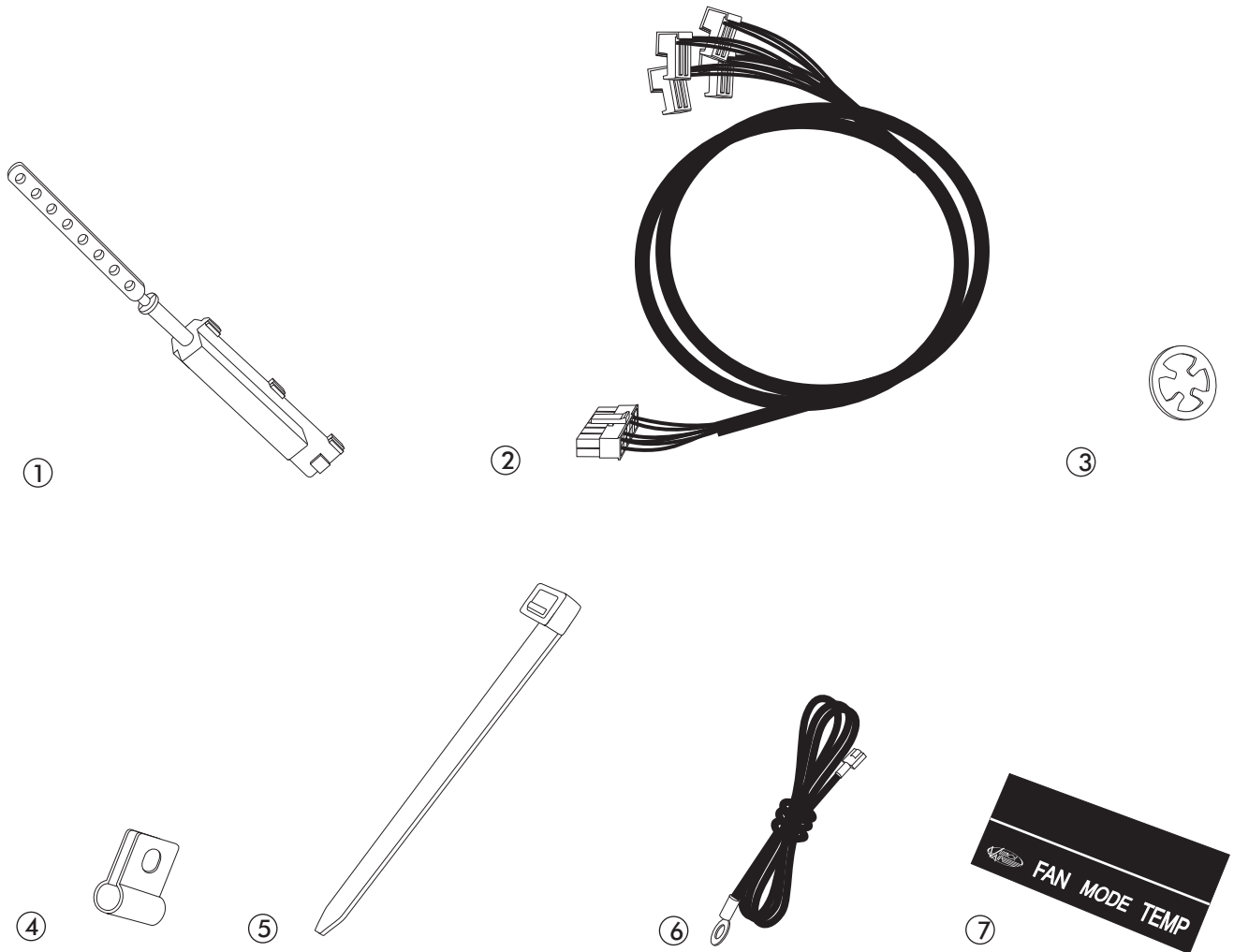

**NOTE: IMAGES MAY NOT DEPICT ACTUAL PARTS AND QUANTITIES.  
 REFER TO PACKING LIST FOR ACTUAL PARTS AND QUANTITIES.**