



an ISO 9001:2008 Registered Company

1960-66 CHEV PICK-UP

CONDENSER KIT

026064

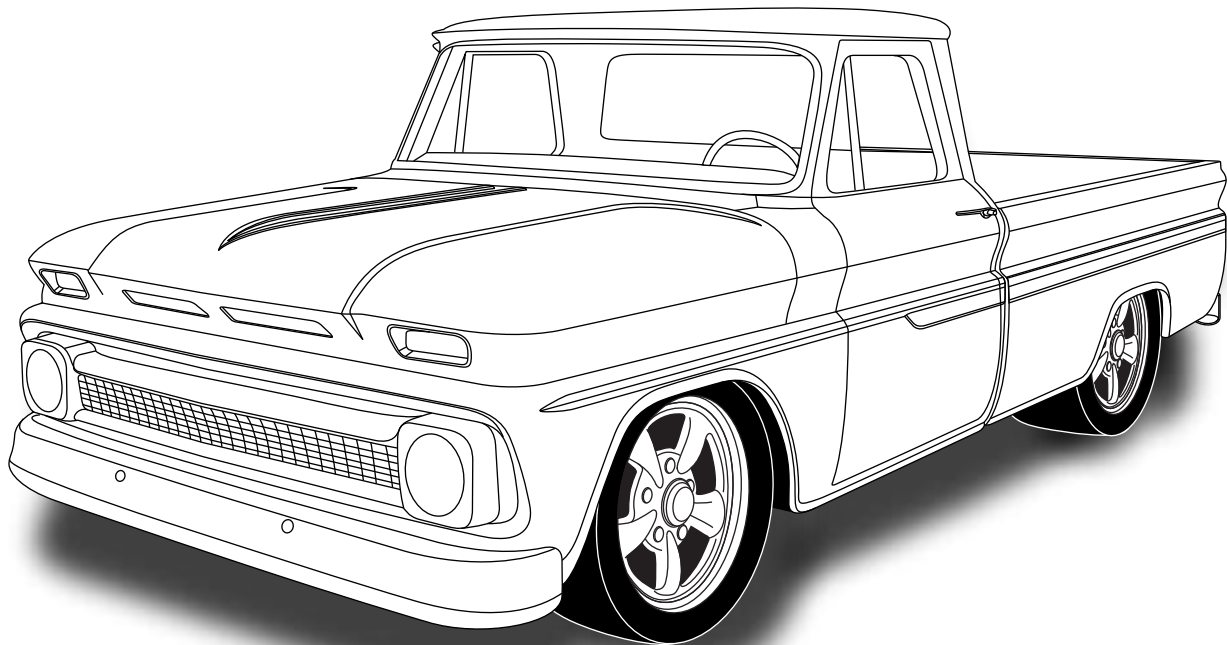

18865 GOLL ST. - SAN ANTONIO, TX. - 78266 ph.210-654-7171 - fax 210-654-3113



TABLE OF CONTENTS

PAGES

1. COVER
2. TABLE OF CONTENTS
3. PACKING LIST/PARTS DISCLAIMER
4. MOUNTING BRACKET INSTALLATION
5. CONDENSER INSTALLATION
6. PACKING LIST



1960-66 CHEV PICK-UP CONDENSER

**CONDENSER KIT
026064**

No.	QTY.	PART No.	DESCRIPTION
1.	1	03768-VUC	17" X 19" SUPER FLOW COND
2.	8	18249-VUB	10-24 X 3/8" PAN HEAD SCREW
3.	8	18260-VUB	10-24 NUT W/STAR WASHER
4.	2	644091	BRKT 60-66 CHEV P-UP COND

BEFORE BEGINNING INSTALLATION OPEN ALL PACKAGES AND CHECK CONTENTS OF SHIPMENT PLEASE REPORT ANY SHORTAGES DIRECTLY TO VINTAGE AIR WITHIN 15 DAYS. AFTER 15 DAYS, VINTAGE AIR WILL NOT BE RESPONSIBLE FOR MISSING OR DAMAGED ITEMS.

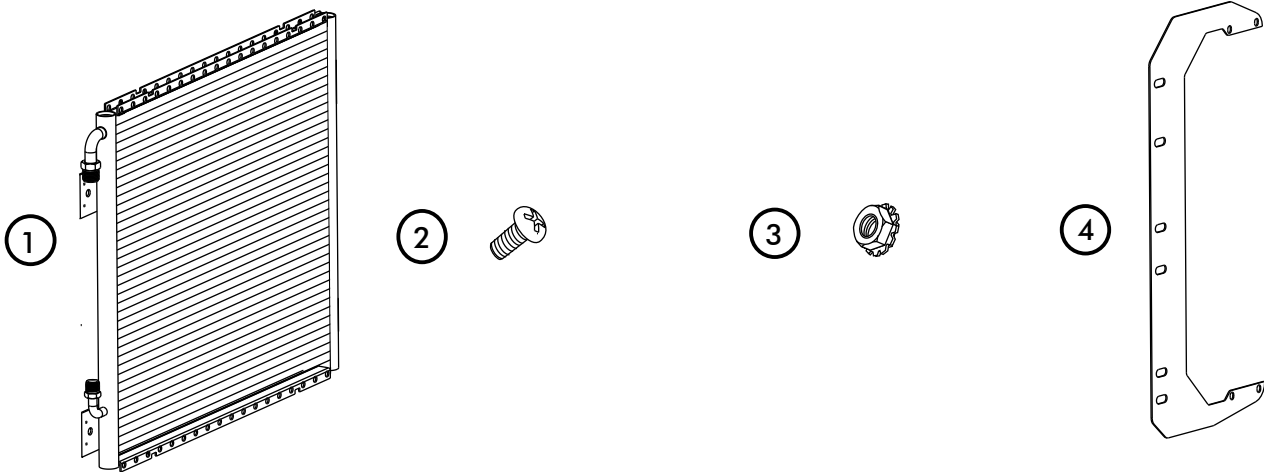



- REMOVE OEM RADIATOR, BATTERY TRAY, AND PASSENGER SIDE BAFFLE. (RETAIN)

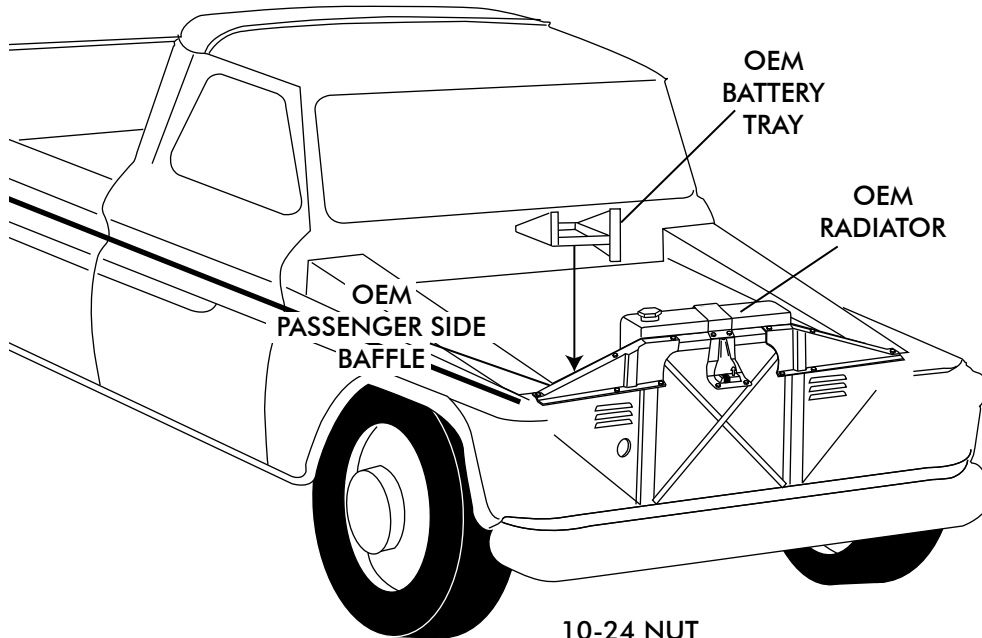

10-24 NUT
w/ STAR WASHER

MOUNTING BRACKET INSTALLATION

- INSTALL MOUNTING BRACKETS ON TO BACK OF CONDENSER USING 10-24 X 3/8" PAN HEAD SCREWS AND 10-24 NUTS WITH STAR WASHERS.

NOTE BRACKET MOUNTS THROUGH THE 2ND & 4TH HOLES OF CONDENSER.

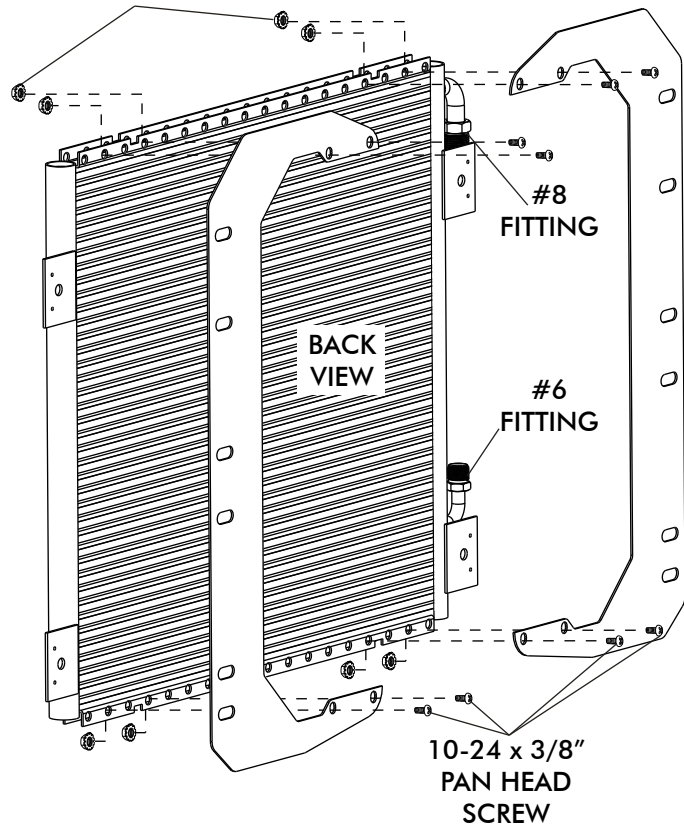



CONDENSER INSTALLATION

- INSTALL CONDENSER/DRIER ASSEMBLY BETWEEN RADIATOR AND ENGINE SIDE OF CORE SUPPORT USING OEM BOLTS AND OEM HOLES AS SHOWN. **NOTE: CONDENSER MOUNTS USING 2ND, 4TH, AND 6TH HOLES FROM TOP OF CONDENSER BRACKETS.**

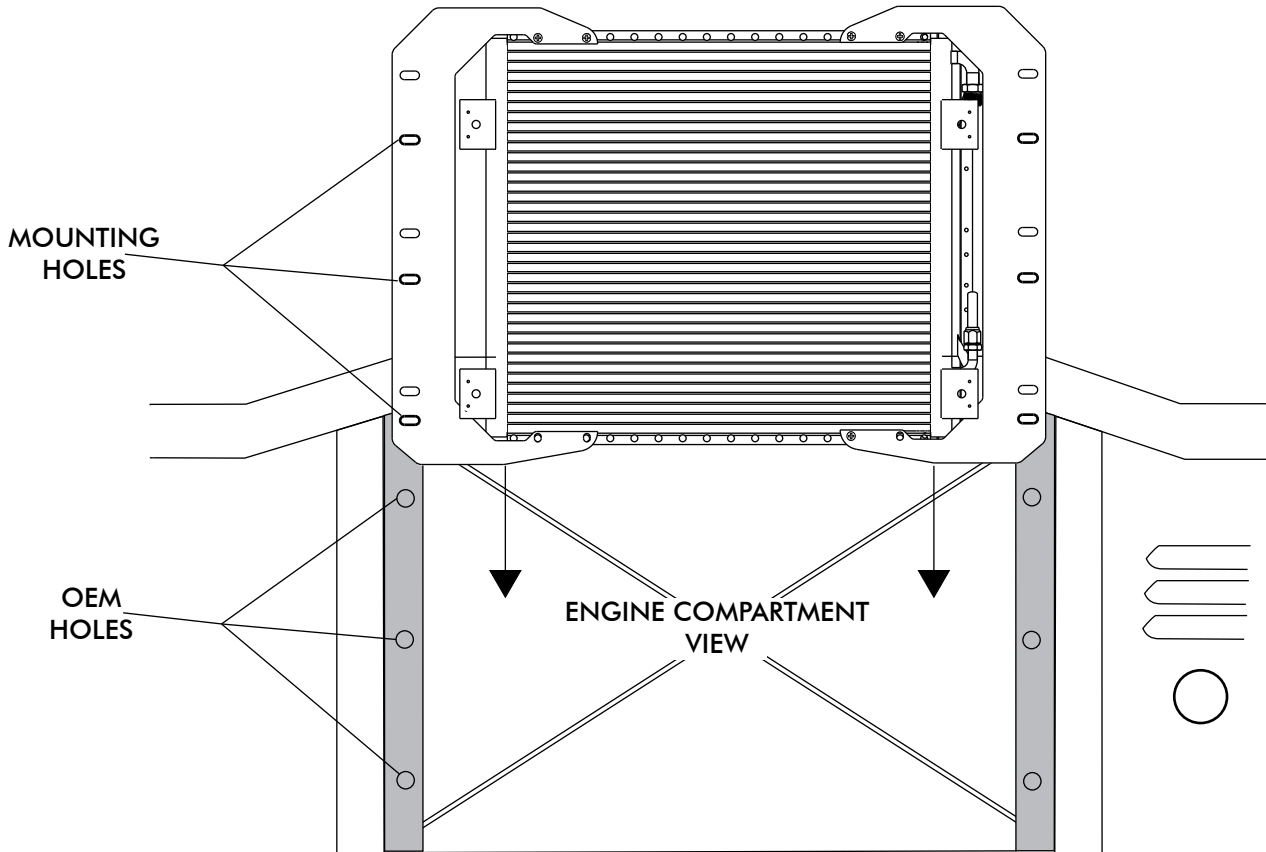



1960-66 CHEV PICK-UP CONDENSER

**CONDENSER KIT
026064**

No.	QTY.	PART No.	DESCRIPTION	
1.	1	03768-VUC	17" X 19" SUPER FLOW COND	_____
2.	8	18249-VUB	10-24 X 3/8" PAN HEAD SCREW	_____
3.	8	18260-VUB	10-24 NUT W/STAR WASHER	_____
4.	2	644091	BRKT 60-66 CHEV P-UP COND	_____

CHECKED BY: _____
 PACKED BY: _____
 DATE: _____

