

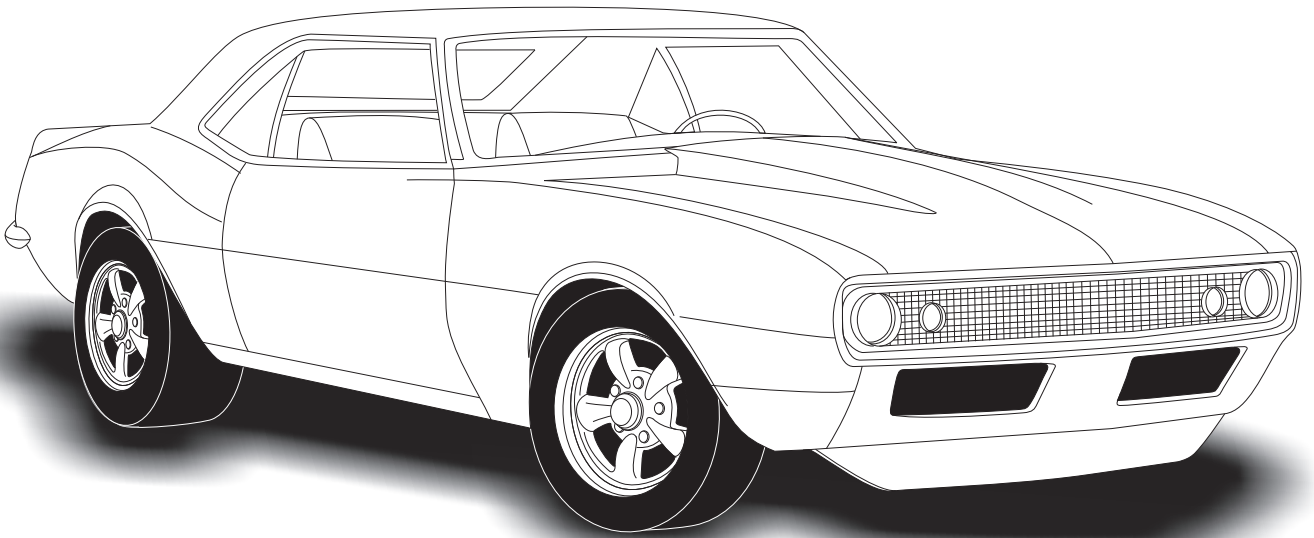

1967-68 CAMARO

w/ & w/o AC CONDENSER KIT w/o DRIER
027067



18865 GOLL ST. - SAN ANTONIO, TX. - 78266 ph.210-654-7171 - fax 210-654-3113



Table of Contents

PAGES

1. COVER
2. TABLE OF CONTENTS
3. PACKING LIST/PARTS DISCLAIMER
4. CONDENSER BRACKET INSTALLATION
FIGURE 1
5. HOOD LATCH ASSEMBLY & CONDENSER INSTALLATION
FIGURES 2 & 3
6. CONDENSER INSTALLATION CONT.
FIGURES 4 & 5
7. PACKING LIST



1967-68 CAMARO CONDENSER KIT w/o DRIER

1967-68 CAMARO w/ or w/o FACTORY AIR CONDENSER KIT w/o DRIER PACKING LIST

CONDENSER KIT
027067

No.	QTY.	PART No.	DESCRIPTION
1.	1	03766-VUC	14" X 22" PARALLEL FLOW COND.
2.	1	18148-VUB	5/16" COARSE NUT
3.	6	18249-VUB	10/24" X 3/8" PH PAN HEAD
4.	6	18260-VUB	10/24" NUT w/STAR WASHER
5.	1	18610-VUB	5/16" LOCK WASHER
6.	2	18611-VUB	5/16" FLAT WASHER
7.	1	18310-VUB	5/16-18" x 1 1/2" COARSE BOLT
8.	2	18977-VUB	5/16" "U" NUT
9.	1	64268-VCB	67-68 CAMARO COND. BRKT. TOP
10.	1	64368-VCB	67-68 CAMARO COND. BRKT. BTM. RT
11.	1	64468-VCB	67-68 CAMARO COND. BRKT. BTM. LF

**** BEFORE BEGINNING INSTALLATION OPEN ALL PACKAGES AND CHECK CONTENTS OF SHIPMENT. PLEASE REPORT ANY SHORTAGES DIRECTLY TO VINTAGE AIR WITHIN 15 DAYS. AFTER 15 DAYS, VINTAGE AIR WILL NOT BE RESPONSIBLE FOR MISSING OR DAMAGED ITEMS.**

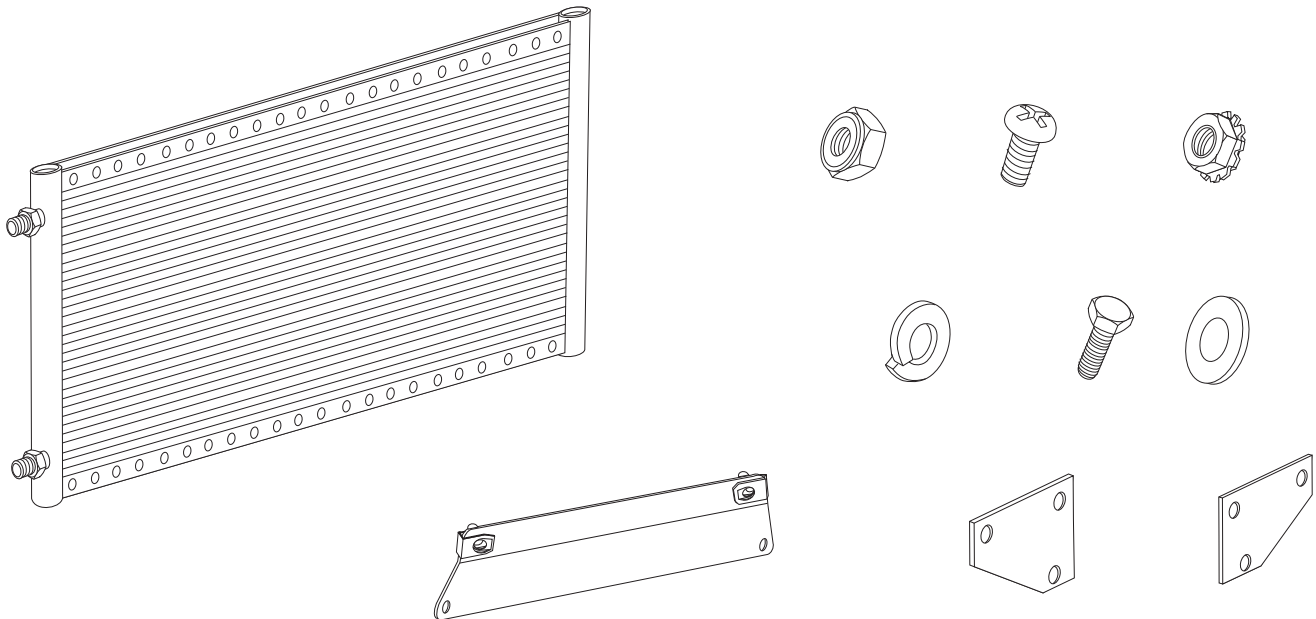

**NOTE: IMAGES MAY NOT DEPICT ACTUAL PARTS AND QUANTITIES.
REFER TO PACKING LIST FOR ACTUAL PARTS AND QUANTITIES**



1967-68 CAMARO CONDENSER KIT w/o DRIER

CONDENSER BRACKET INSTALLATION

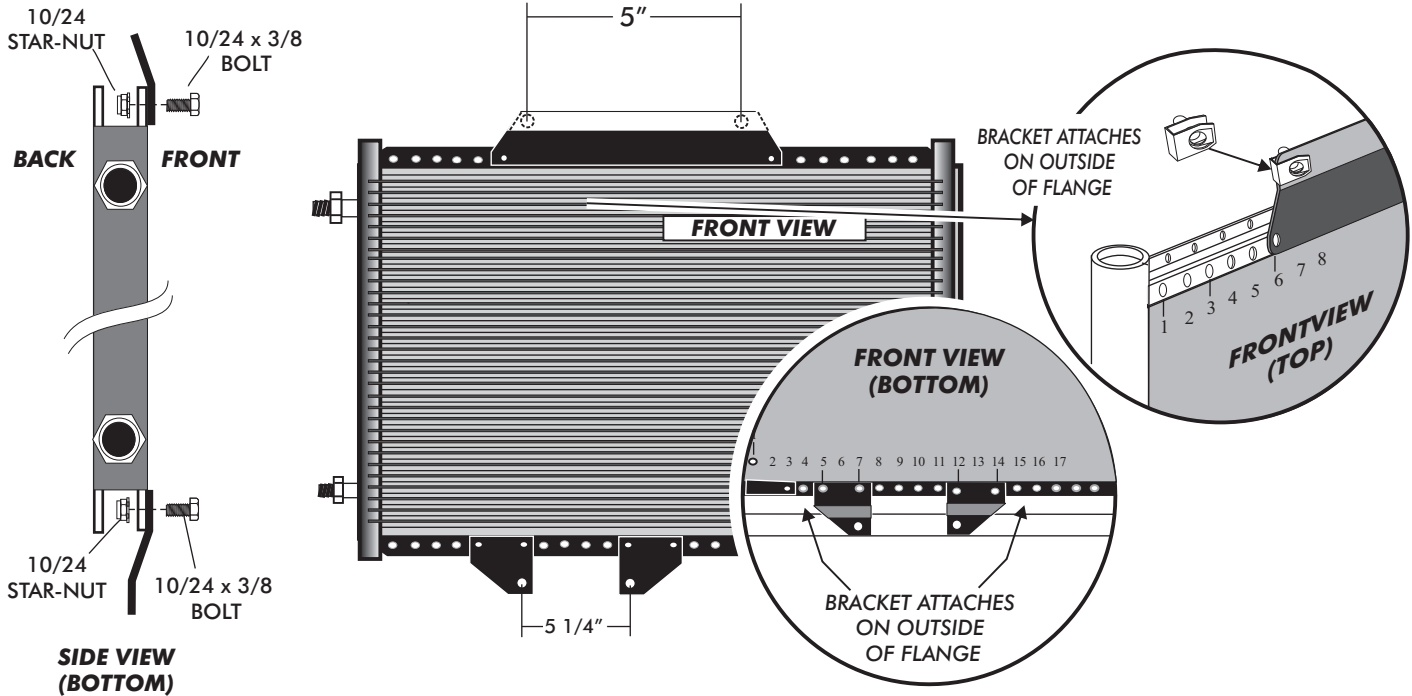

- ❑ INSTALL TOP MOUNTING BRACKET ON TO CONDENSER USING (2) 10/24 x 3/8 PAN HEAD SCREWS AND (2) 10/24 NUTS WITH STAR WASHERS. SEE FIGURE BELOW.

NOTE: BRACKET MOUNT THROUGH THE 6TH HOLE FROM THE LEFT SIDE OF THE CONDENSER.

- ❑ INSTALL BOTTOM MOUNTING BRACKETS ON CONDENSER USING (4) 10/24 x 3/8 PAN HEAD SCREWS AND (4) 10/24 NUTS w/ STAR WASHERS. SEE FIGURE 1 BELOW

FIGURE 1

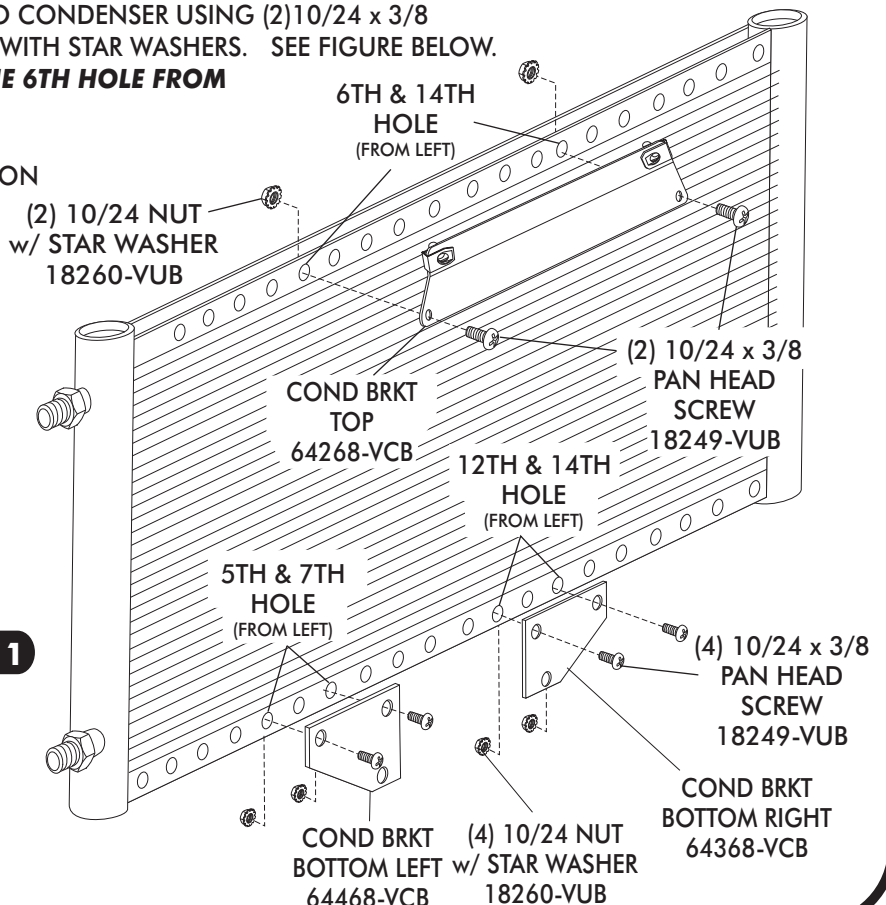



HOOD LATCH ASSEMBLY

- REMOVE OEM HOOD LATCH ASSEMBLY
SEE FIGURE 2 BELOW.

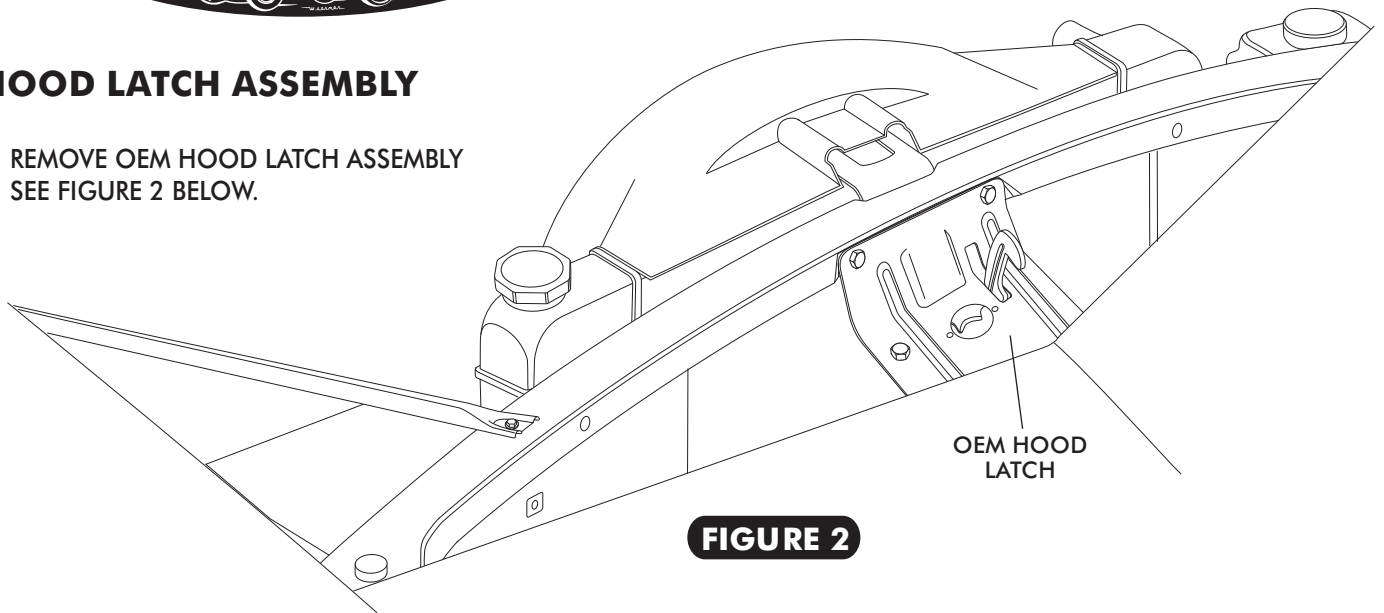

FIGURE 2

CONDENSER INSTALLATION

- INSTALL CONDENSER AS SHOWN BELOW, LOWER CONDENSER
BETWEEN THE FRONT SIDE OF THE CORE SUPPORT
AND THE FRONT HEADER
SEE FIGURE 3 BELOW.

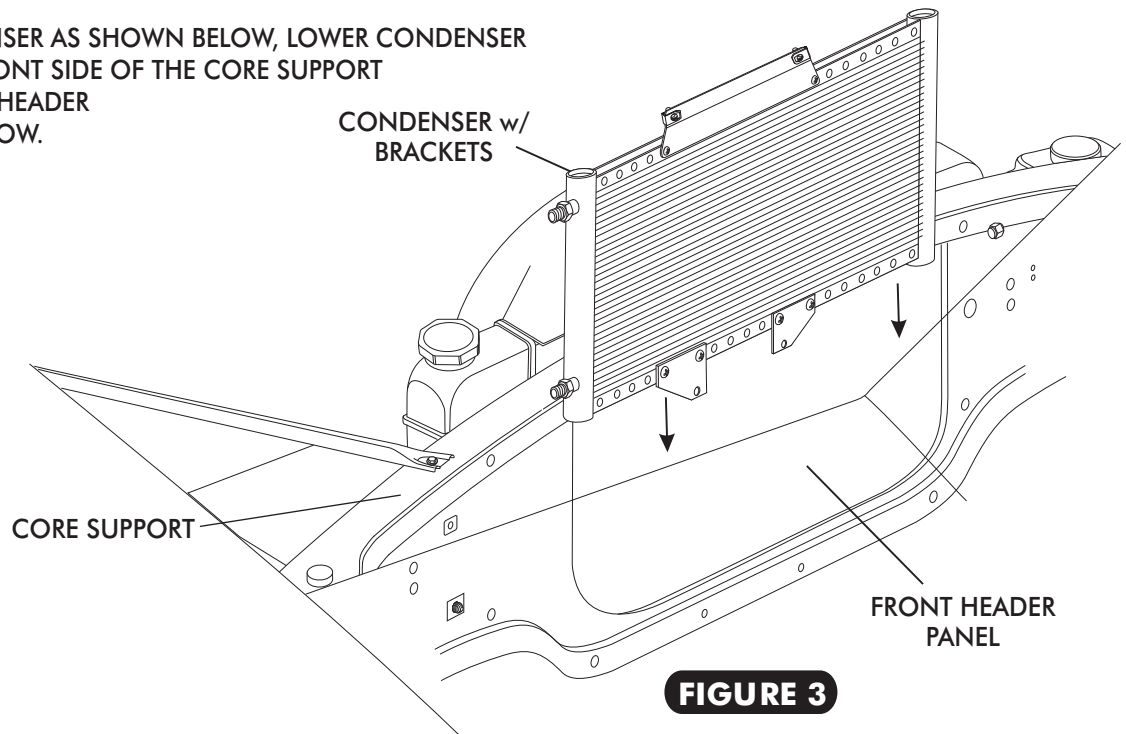

FIGURE 3



CONDENSER INSTALLATION CONT.

- NOTE: THE TOP MOUNTING BRACKET GOES ON THE BACKSIDE OF THE CORE SUPPORT.
- SECURE THE BOTTOM DRIVER SIDE OF THE CONDENSER TO THE CORE SUPPORT USING A 5/16-18 x 1 1/2" HEX BOLT, FLAT WASHER, LOCK WASHER, AND 5/16 HEX NUT. SEE FIGURE 4, BELOW.
- SECURE THE BOTTOM PASSENGER SIDE OF THE CONDENSER TO THE CORE SUPPORT USING OEM BOLT. SEE FIGURE 4, BELOW.

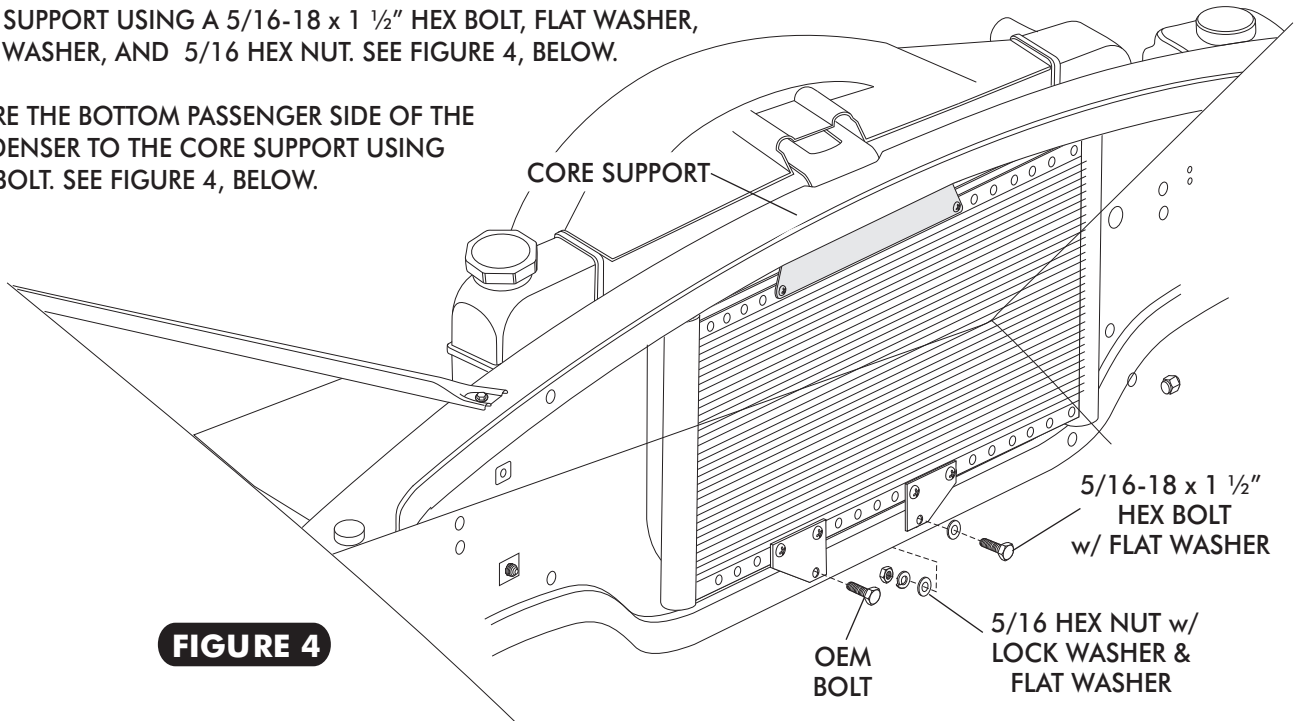

FIGURE 4

- USING OEM BOLTS RE-INSTALL HOOD LATCH ASSEMBLY, INSTALL OEM BOLTS THROUGH THE HOOD LATCH ASSEMBLY THROUGH THE CORE SUPPORT AND THREAD BOLTS INTO U-NUTS ON THE TOP CONDENSER BRACKET. SEE FIGURE 5 BELOW

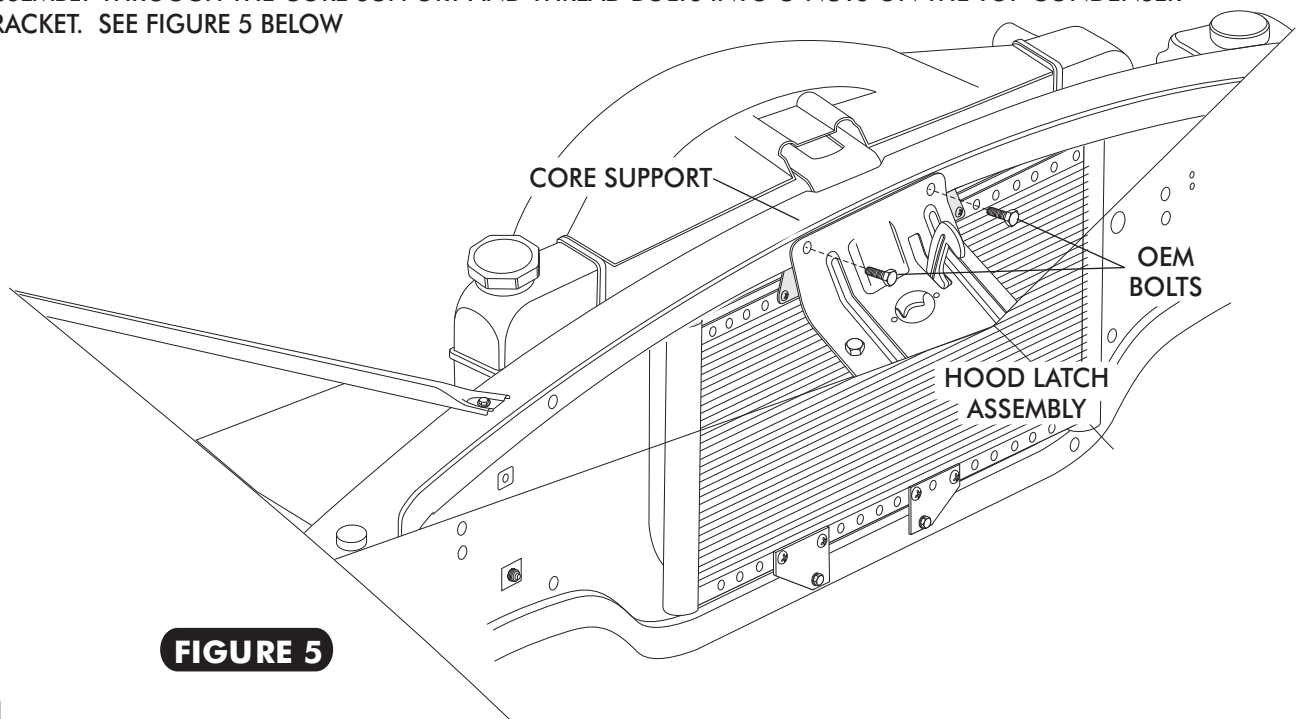

FIGURE 5



1967-68 CAMARO CONDENSER KIT w/o DRIER

1967-68 CAMARO w/ or w/o FACTORY AIR CONDENSER KIT w/o DRIER PACKING LIST

CONDENSER KIT
027067

No.	QTY.	PART No.	DESCRIPTION	
1.	1	03766-VUC	14" X 22" PARALLEL FLOW COND.	_____
2.	1	18148-VUB	5/16" COARSE NUT	_____
3.	6	18249-VUB	10/24" X 3/8" PH PAN HEAD	_____
4.	6	18260-VUB	10/24" NUT w/STAR WASHER	_____
5.	1	18610-VUB	5/16" LOCK WASHER	_____
6.	2	18611-VUB	5/16" FLAT WASHER	_____
7.	1	18310-VUB	5/16-18" x 1 1/2" COARSE BOLT	_____
8.	2	18977-VUB	5/16" "U" NUT	_____
9.	1	64268-VCB	67-68 CAMARO COND. BRKT. TOP	_____
10.	1	64368-VCB	67-68 CAMARO COND. BRKT. BTM. RT	_____
11.	1	64468-VCB	67-68 CAMARO COND. BRKT. BTM. LF	_____

CHECKED BY: _____
 PACKED BY: _____
 DATE: _____

