



**PERFORMANCE AUTOMOTIVE
AIR CONDITIONING**

THE BASICS

18865 GOLL ST. - SAN ANTONIO, TX. - 78266 ph.210-654-7171 - fax 210-654-3113

The Basics of Performance Air Conditioning

1. Primary purpose of air conditioning is to remove heat and humidity from inside the vehicle.
2. How system works.

Refrigerant absorbs heat as it changes states from liquid to gas, (in evaporator) dissipates heat as it changes from gas to liquid in condenser.

*Heat is absorbed through evaporation, dissipated through condensation. (Change of states)

*Refrigerant is high-pressure liquid (high side) low-pressure gas (low side) or suction side.

3. List of basic air conditioning components and purpose.

Evaporator with expansion valve – evaporator absorbs heat/humidity – valve regulates flow of refrigerant.

Compressor – pumps refrigerant through system.

Condenser – cools refrigerant to induce change from gas to liquid.

Receiver/Drier – filters refrigerant, separates vapor from liquid refrigerant, removes moisture.

*Safety switches

- a. Binary - High (406 PSI) and Low (30 PSI) pressure protection
- b. Trinary - High (406 PSI) and Low (30 PSI) pressure plus an electric fan engagement signal at 254 PSI (on high pressure side)

*Thermostat - adjusts compressor cycle time. (Indirect temperature control)

*Explain evaporator freeze up (internal & external)

4. Refrigerants:

CFC-12 - R-134a - blends/replacements - Vintage Air does not recommend blends.

R-134a is a more efficient absorber and carrier of heat, hence the need for larger or more efficient condenser with R-134a refrigerant to keep high side operating pressures within acceptable range.

- 134a molecules smaller – require “O” ring fittings and barrier hose must be crimp connections, no clamps.
- Crimps: 134a standard is beadlock - always recommended!

- Always fill by volume 1.8 PSI with good scale! (Standard Vintage Air System) (Note: 1.8 lbs = 28.8 oz)
 - * Extremely long liquid line or suburban size condenser would require additional charge.
- 5. When to consider air conditioning for your project:
 - *Very early in planning/building phase.
- Mount engine far enough back to allow for condenser, fan, shroud and radiator.
- Use largest evaporator possible.
 - Install evaporator in dash/cowl area first, and position other components around it.

Mounting compressor:

- Do not distort compressor body when mounting. (May cause oil leak)
- Minimum "Grade 5" bolts & sturdy, supportive bracket.
- Align pulleys well!
- At least 1/3" belt wrap – belt should contact/drive sides of pulley. (Should not bottom out in groove)
 - R134a oil - Pag 016. Sanden recommends SP-20 oil
 - 90° maximum "clocking" to retain oil - on Sanden SD508 Compressor.
 - Clutch air gap - .016 - .031

Drier:

- Mount upright in airflow or cool area. (May be mounted inside vehicle.)
- Drier/safety switch combination convenient way to package safety switch.

Condenser:

- In front of radiator up to 3/16" gap - do not place against radiator.
- 1-1/4 volume of evaporator coil. (in³)
- Parallel flow condenser has 25% more capacity than same size tube & fin.
- Under car condenser not recommended for 134a. (As primary condenser)

***Remember – temperature differential induces heat transfer. Air under car is much warmer and more stagnant than clean air coming at front of car.**

- Size evaporator to car – always try to package the largest evaporator possible.
- Mount solid, level – pay attention to drain hole and tube!
*Seal and insulate car!!
- Stretch duct hose to eliminate “ribbing,” reduce turbulence. Route duct hose with smooth, gentle bends. Try not to kink or crush.
- Form ducts?
- Never cap un-used evaporator outlets! Creates cavitation and “cold spots” in coil – may lead to evaporator freeze up.
- Do not completely seal off under dash (air can not re-circulate to blower).
- Cool air drops, so locate vents high enough to blow air on/past people.

TIPS:

- **Seal and insulate cabin area (including cowl and above evaporator).**
- Make sure cooling system and radiator is sufficient.
 - *Remember, without adequate airflow, a radiator is just a reservoir for hot water. In general, coolant transfers heat to radiator tubes, tubes transfer heat to fins, and movement of air through the fins removes heat from the radiator. You must allow air to pass efficiently through the radiator and out!
 - *Allow for air to escape from under hood.
 - *On Walker Radiator or aftermarket: 15-18 lb. Cap.
each 1 lbs. of increased pressure raises boiling point 3° F,
 - *On original recore radiator: 4-7 lb. Cap (tanks not designed to hold pressure).
- Remember: Anti-freeze increases boiling point of water (now called anti-freeze/coolant) - proper mix (50% coolant to 50% water). Corrosion inhibitors protect against scaling and mineral build-up that can reduce heat transfer. Also, proper maintenance (flushing & changing coolant) will extend life of system.
 - not benefit from the housing effect the shroud provides.
- If using an engine driven fan use a shroud. An unshrouded fan only moves air through the portion of the radiator equal to the surface of the fan. A shroud also dramatically improves the efficiency of the fan and does not benefit from the housing effect the shroud provides. An unshrouded fan moves about 50% the volume of a shrouded fan.
 - *Fan should be 1/2 to 2/3 inside of shroud for best performance.
- Water pumps should be overdriven 30 – 35%. (Pulley ratio - crankshaft pulley should be 30% larger than water pump pulley.)
- Always use a thermostat to control engine temperature.

REFRIGERATION FLOW

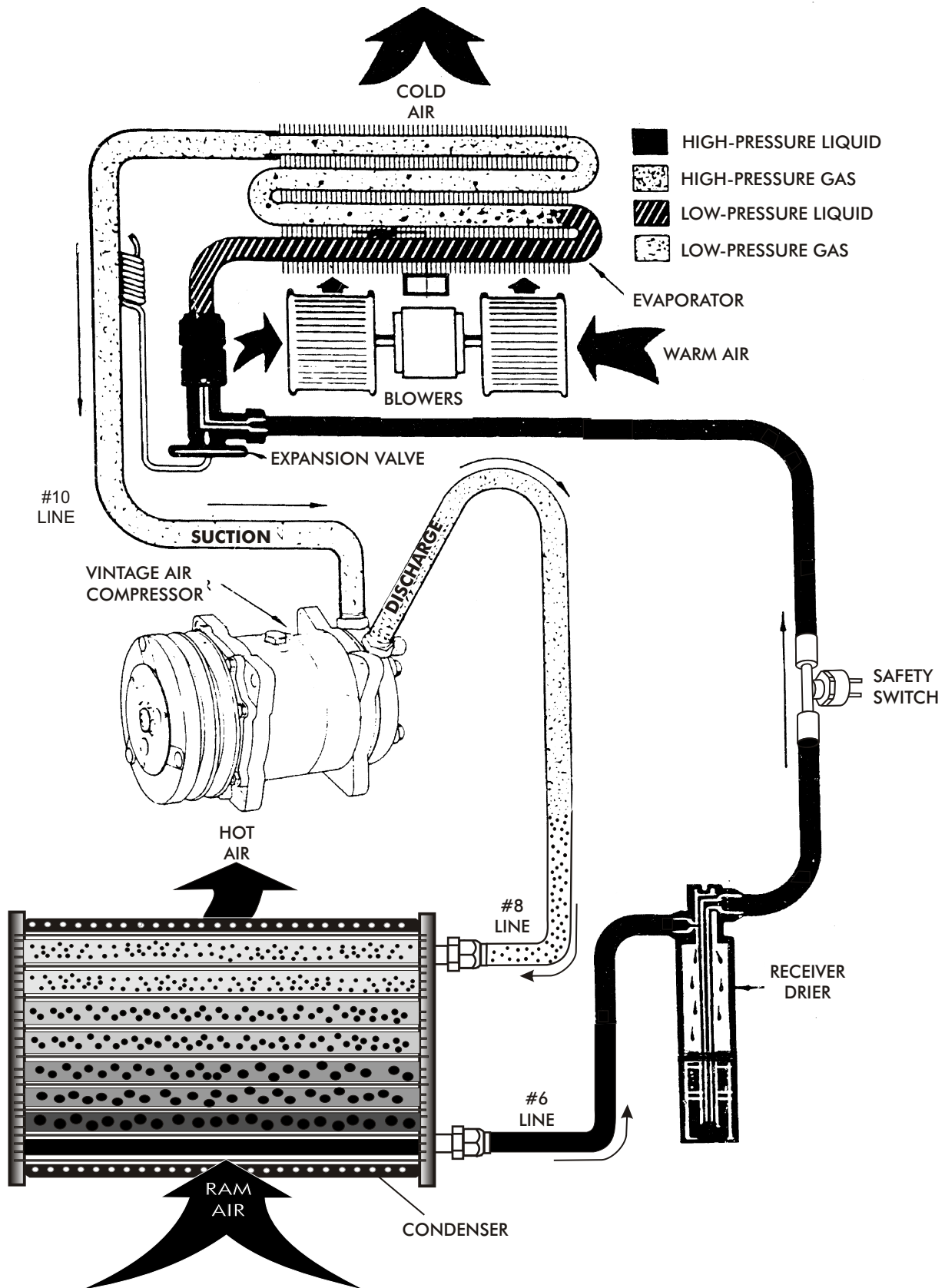

Basic Air Conditioning Components

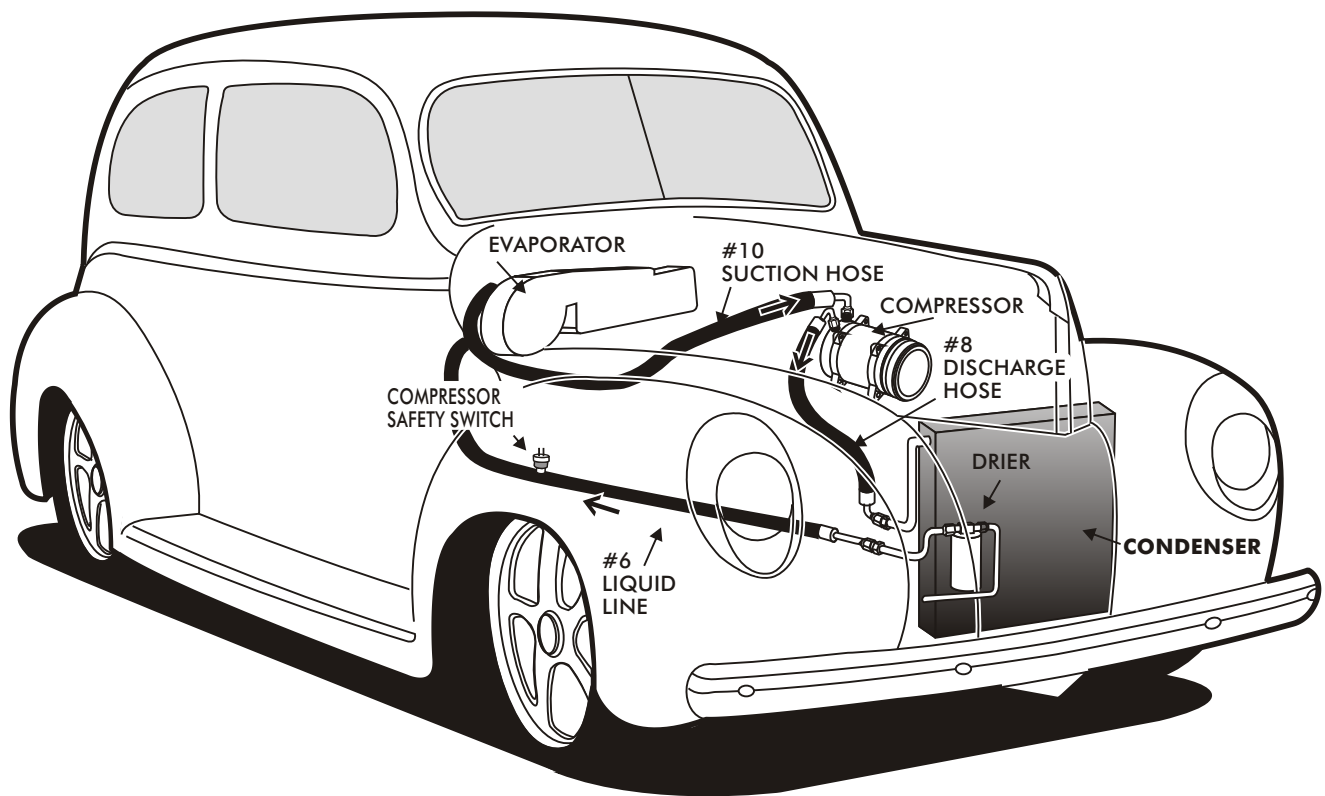

Direction of Refrigerant Flow indicated by
Arrows

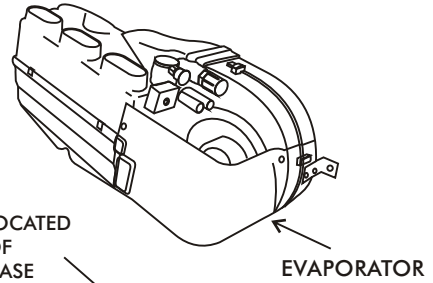
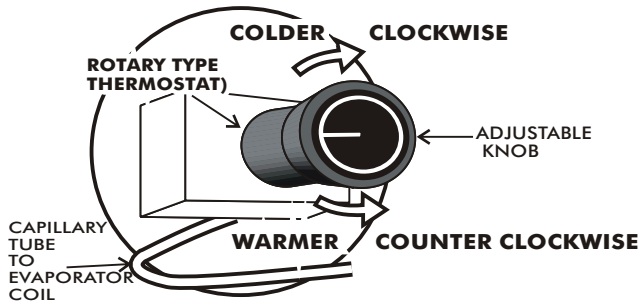

THIS STICKER LOCATED ON TOP SIDE OF EVAPORATOR CASE

EVAPORATOR

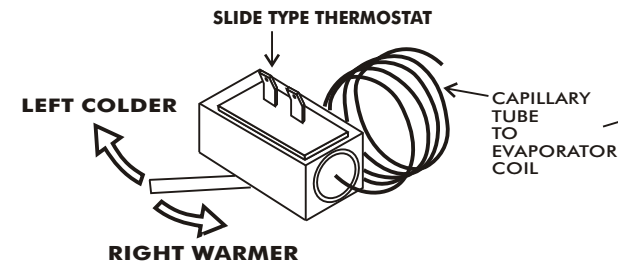

NOTE: YOUR SYSTEM MAY HAVE A ROTARY OR SLIDE TYPE THERMOSTAT. IF YOU ARE UPGRADING TO A NEW CONTROL PANEL, USE THE THERMOSTAT INCLUDED WITH THE NEW PANEL. REMOVE YOUR ORIGINAL THERMOSTAT AND DISCARD.

AIR CONDITIONING ADJUSTMENTS:

- THE AIR CONDITIONER THERMOSTAT CONTROLS COIL TEMPERATURE. ROTARY TYPE THERMOSTATS ARE SHIPPED ADJUSTED FULLY COLD (CLOCKWISE), IN THE MAJORITY OF CASES THE A/C WILL OPERATE CORRECTLY AS SHIPPED.
- TURNING THE KNOB ON THE **ROTARY TYPE THERMOSTAT** TO THE RIGHT (CLOCKWISE) MAKES THE SYSTEM OPERATE COLDER. MOVING THE LEVER TOWARD COLDER ON THE **SLIDE TYPE THERMOSTAT** MAKES THE SYSTEM OPERATE COLDER. IF THE THERMOSTAT IS SET TOO COLD THE EVAPORATOR COIL WILL "ICE UP"- MEANING, THE EVAPORATOR COIL IS RESTRICTED WITH ICE AND COLD AIR FLOW WILL BE REDUCED.
- TURNING THE KNOB TO THE LEFT (COUNTER CLOCKWISE) ON A **ROTARY TYPE THERMOSTAT** MAKES THE SYSTEM OPERATE WARMER. MOVING THE LEVER TOWARD S THE RED LINES ON A **SLIDE TYPE THERMOSTAT** MAKES THE SYSTEM OPERATE WARMER. THE COMPRESSOR CLUTCH WILL CYCLE OFF FREQUENTLY. THE EVAPORATOR COIL WILL NOT GET AS COLD AND THE AIR TEMPERATURE WILL NOT BE AS COLD.

ADJUSTING A/C THERMOSTAT

- 1.) **SYMPTOM:** THE A/C WORKS WELL AT FIRST THEN QUILTS COOLING. THE AIR FLOW FROM THE VENTS IS LOW, AND THE COMPRESSOR CLUTCH CYCLES INFREQUENTLY.
SOLUTION: THE THERMOSTAT IS SET TOO COLD AND THE EVAPORATOR IS "ICING UP" AND RESTRICTING AIR FLOW. **ALLOW THE ICE TO MELT** AND SET THE **ROTARY TYPE THERMOSTAT** WARMER (COUNTER CLOCKWISE) 1/8 OF A TURN EACH ADJUSTMENT UNTIL THE SYMPTOMS DIMINISH. ADJUST THE **SLIDE TYPE THERMOSTAT** IN 1/8" INCREMENTS TOWARDS THE SMALLER BLUE GRADIENTS, UNTIL THE SYMPTOMS DIMINISH.
- 2.) **SYMPTOM:** A/C NEVER GETS COLD AND THE COMPRESSOR CLUTCH CYCLES FREQUENTLY.
SOLUTION: THE THERMOSTAT IS SET TOO WARM. SET THE **ROTARY TYPE THERMOSTAT** COLDER (CLOCKWISE) 1/8 OF A TURN EACH ADJUSTMENT, UNTIL THE DESIRED AIR TEMPERATURE IS REACHED. ADJUST **SLIDE TYPE THERMOSTAT** IN 1/8" INCREMENTS TOWARDS COLDER UNTIL THE DESIRED AIR TEMP IS REACHED **AVOID SETTING THE THERMOSTAT TOO COLD.**
- 3.) **SYMPTOM:** THE A/C NEVER GETS COLD, SOMETIMES EVEN BLOWS HOT, AND THE A/C COMPRESSOR CLUTCH INFREQUENTLY CYCLES OFF.
SOLUTION: THE HEATER MAY BE ON AT ALL TIMES. **CAREFULLY** FEEL THE HEATER HOSE BETWEEN THE **EVAPORATOR** AND THE **HEATER CONTROL VALVE**. THIS HOSE SHOULD NOT BE HOT IN THE **A/C MODE**. IF THE HOSES ARE HOT
 - A)- THE HEATER CONTROL VALVE MAY BE INSTALLED BACKWARDS. CHECK THE FLOW DIRECTION ARROW ON THE VALVE AGAINST THE ILLUSTRATION IN YOUR INSTALLATION INSTRUCTIONS.
 - B)- IF CABLE OPERATED: THE VALVE MAY BE MISADJUSTED.
 - C)- IF VACUUM OPERATED: IT MAY BE GETTING VACUUM AT ALL TIMES (CHECK ELECTRIC SOLENOID).
 - D)- THE HEATER CONTROL VALVE MAY BE INSTALLED IN THE WRONG HOSE. IT MUST BE INSTALLED IN THE HOSE COMING FROM THE INTAKE MANIFOLD ENGINE COOLANT **PRESSURE PORT**.

MOUNTING AND BELT ADJUSTMENT DIAGRAM

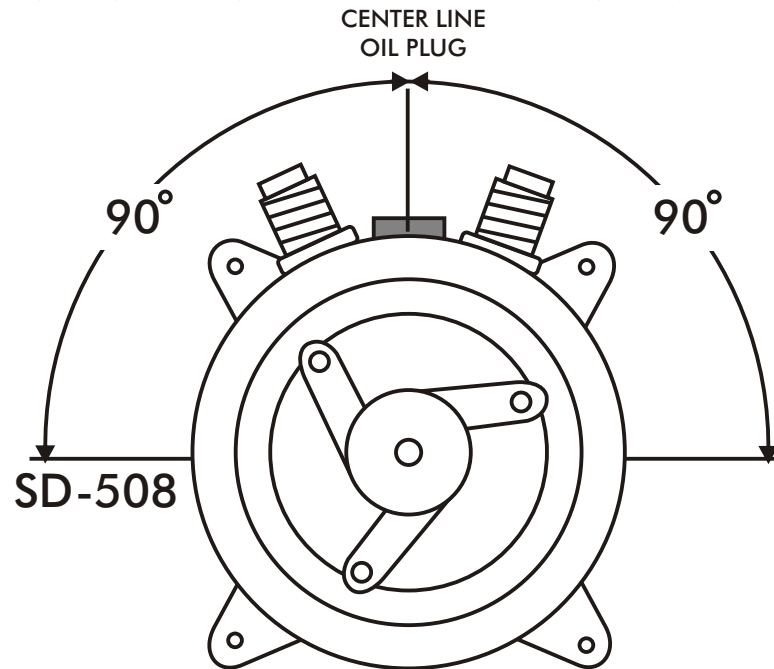

COMPRESSORS ARE FACTORY CHARGED WITH OIL

WARNING

1. WHEN MOUNTING AND ADJUSTING YOUR BELT, MAKE SURE THE CENTERLINE OF COMPRESSOR DOES NOT EXCEED 90 DEGREES. GOING PAST 90 DEGREES WILL CAUSE LOSS OF OIL CHARGE AND RESULT IN COMPRESSOR FAILURE.
2. DO NOT CONNECT COMPRESSOR CLUTCH WIRE UNTIL SYSTEM IS BEING CHARGED WITH REFRIGERANT. RUNNING COMPRESSOR WITHOUT REFRIGERANT CHARGE WILL RESULT IN COMPRESSOR FAILURE.
3. VINTAGE AIR RECOMMENDS ONLY DAYCO, GATES, OR GOODYEAR BRAND REINFORCED SERIES 17 V BELT BE USED WITH THIS COMPRESSOR. ANY USE OF LESSER QUALITY BELTS MAY CAUSE COMPRESSOR TO PERFORM IMPROPERLY.

NOTE: FAILURE TO FOLLOW THESE PROCEDURES VOIDS ALL WARRANTIES.

IMPORTANT NOTICE

DO NOT CONNECT COMPRESSOR
CLUTCH WIRE UNTIL SYSTEM IS
BEING CHARGED WITH REFRIGERANT.
RUNNING COMPRESSOR WITHOUT
REFRIGERANT WILL VOID WARRANTY.

A/C HOSE CRIMPS

BEADLOCK CRIMPING TOOL

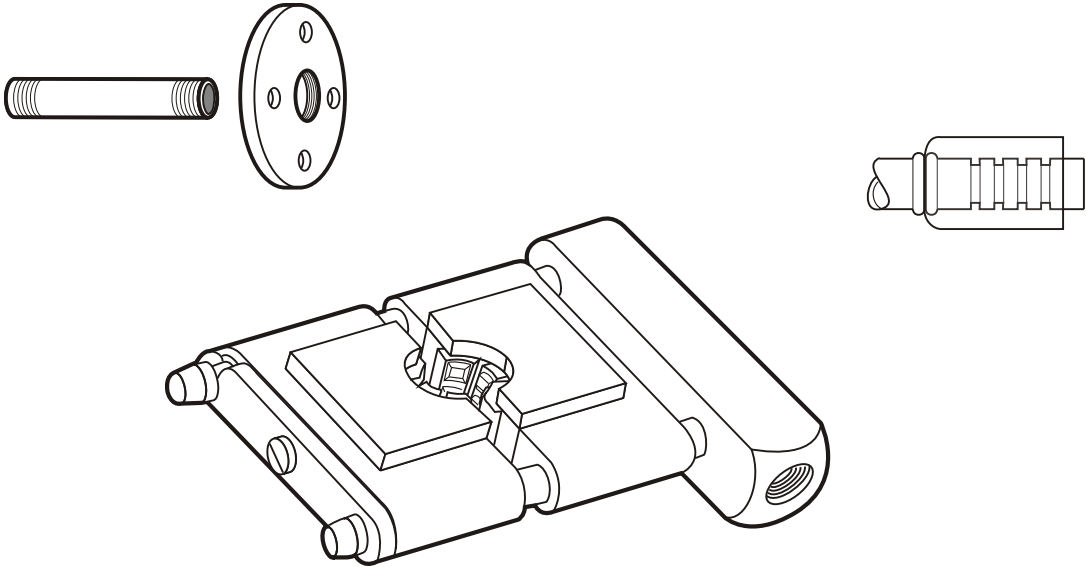

BARB FITTING CRIMPING TOOL

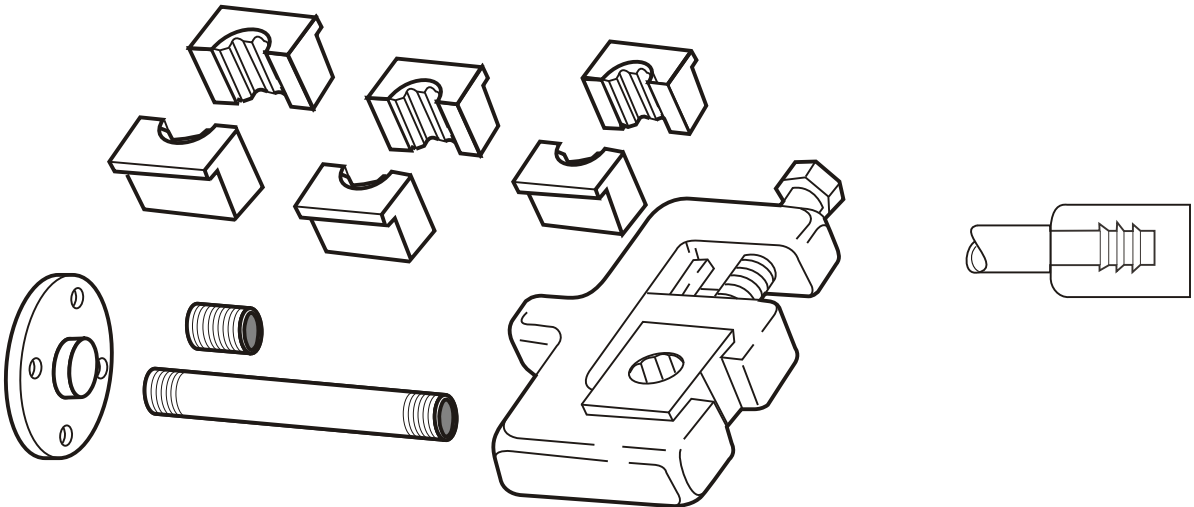

Vintage Air Service Procedure Guide Without Recovery and Charge Station

Finish installation. If using new Sanden Compressor, do not add oil to system. New Sanden Compressors are pre-charged with 7.2 oz of PAG Oil.

Put gauges on car.

Evacuate for 30 to 60 minutes, system should reach at least 29" inches of vacuum for 5 minutes (with room temperature at 85° or warmer or components heated).

Turn off vacuum pump, close valves and watch for vacuum drop as a clean leak check.

Do not start engine yet. Open both sides for a static charge. Charge into hi & low side with proper charge. If refrigerant does not continue to flow, you may want to immerse refrigerant container (a little over half way) in a pan of warm water (up to 100° F) to complete static charge.

After proper charging, turn compressor over by hand 5 or 6 times before operating system.

If charging without warm water assist, charge through both sides as long as refrigerant will flow into system. Turn compressor over by hand 5 or 6 times and close high side valve.

Start engine and finish charging through low side until system is charged with proper amount. Vintage Air systems require 1.8 lbs. (28.8 oz) of 134a Refrigerant.

Leak check and evaluation performance.

- * Doors & windows closed
- * Med./Hi blower
- * Engine RPM - 1500
- * Duct temp. - 42-48°
- * Pressures stabilized
- * Hi-side - 2X ambient + 10 to 20%
- * Low side - 8 to 15 lbs. In steady state to cycle (HFC-134a)

Notes:

Gas charging is safest; however, most compressors today do have anti-slug valves. Always charge with manufacturers recommended charge. If you don't think the charge is working correctly, call Vintage Air.

Oil:

New compressor - no additional oil needed - if using remote condenser or rear-mounted system, call Vintage Air for advice on possible additional refrigerant.

Used compressors - call Vintage Air
Leak check - dye - soap/water

Recommendations.

Inject a quality leak detection dye at time of charging.
Bead lock fittings crimped with (bubble crimp) crimping tool are best option with barrier hose.

NOTE: This procedure applies when using complete Vintage Air System only.

Vintage Air Service Procedure Guide With Recovery and Charge Station

Finish installation. If using new Sanden Compressor, do not add oil to system. New Sanden Compressors are pre-charged with 7.2 oz of PAG Oil.

Put gauges on car.

Evacuate for 30 to 60 minutes, system should reach at least 29" inches of vacuum for 5 minutes (with room temperature at 85° or warmer or components heated).

Turn off vacuum pump, close valves and watch for vacuum drop as a clean leak check.

Do not start engine yet. Open both sides for a static charge. Charge into hi & low side with proper charge. If refrigerant does not continue to flow, you may want to immerse refrigerant container (a little over half way) in a pan of warm water (up to 100° F) to complete static charge.

After proper charging, turn compressor over by hand 5 or 6 times before operating system.

If charging without warm water assist, charge through both sides as long as refrigerant will flow into system. Turn compressor over by hand 5 or 6 times and close high side valve.

Start engine and finish charging through low side until system is charged with proper amount. Vintage Air systems require 1.8 lbs. (28.8 oz) of 134a Refrigerant.

Leak check and evaluation performance.

- * Doors & windows closed
- * Med./Hi blower
- * Engine RPM - 1500
- * Duct temp. - 42-48°
- * Pressures stabilized
- * Hi-side - 2X ambient + 10 to 20%
- * Low side - 8 to 15 lbs. In steady state to cycle (HFC-134a)

Notes:

Gas charging is safest; however, most compressors today do have anti-slug valves. Always charge with manufacturers recommended charge. If you don't think the charge is working correctly, call Vintage Air.

Oil:

New compressor - no additional oil needed - if using remote condenser or rear-mounted system, call Vintage Air for advice on possible additional refrigerant.

Used compressors - call Vintage Air

Leak check - dye - soap/water

Recommendations.

Inject a quality leak detection dye at time of charging.

Bead lock fittings crimped with (bubble crimp) crimping tool are best option with barrier hose.

NOTE: This procedure applies when using complete Vintage Air System only.

TROUBLESHOOTING GUIDE

The following guide will help the installer determine if a problem exists in the system that would cause a malfunction. **If you are experiencing problems in the physical operation of the unit (blower speeds, door operation, etc.) We encourage you to refer to the wiring diagram located in the instruction manual.** Using a continuity or light tester you can solve many of the simple problems by tracing a connections, and testing them individually. However, if the unit is functioning correctly, but it is not cooling, you can refer to the following guide that will outline the most common problems encountered by installers.

I. TEST CONDITIONS USED TO DETERMINE SYSTEM OPERATION

- A. PLACE TEMPERATURE PROBE (THERMOMETER) INTO CENTER OUTLET.
- B. CONNECT THE GAUGES OR SERVICE EQUIPMENT TO THE HIGH/LOW CHARGING PORTS.
- C. PLACE BLOWER FAN SWITCH ON MEDIUM.
- D. CLOSE ALL DOORS AND WINDOWS ON VEHICLE.
- E. PLACE SHOP FAN OR HEAVY DUTY SQUIRREL-CAGE BLOWER DIRECTLY IN FRONT OF THE CONDENSER.
- F. RUN ENGINE IDLE UP TO 1500 RPM

(THESE TEST CONDITIONS WILL SIMULATE THE AFFECT OF DRIVING THE VEHICLE AND GIVE THE TECHNICIAN THE THREE CRITICAL READINGS THAT THEY WILL NEED TO DIAGNOSE ANY POTENTIAL PROBLEMS)

II. ACCEPTABLE OPERATING PRESSURE RANGES FOR VINTAGE AIR SYSTEMS

A. R134A TYPE

1. **HIGH-SIDE PRESSURE** (160 - 250 PSI) * Note - general rule of thumb is two times the ambient (daytime) temperature, plus 15 - 20%.
2. **LOW-SIDE PRESSURE** (06- 12 PSI in a steady state)
3. **CENTER DUCT TEMPERATURE** (36 - 46 DEGREES F.)

B. R12 TYPE

1. **HIGH-SIDE PRESSURE** (140 - 230 PSI) * Note - general rule of thumb is two times the ambient (daytime) temperature, plus 15%.
2. **LOW-SIDE PRESSURE** (12- 15 PSI in a steady state)
3. **CENTER DUCT TEMPERATURE** (36 - 46 DEGREES F.)

**Charges as follows R134A = 1.8 lbs. R12 = 2.0 lbs.
No additional oil is necessary in new compressors**

III. TYPICAL PROBLEMS ENCOUNTERED IN CHARGING SYSTEMS

A. NOISY COMPRESSOR

1. A noisy compressor is generally caused by over charging the system or introducing outside air into the system.
 - a. If a system is over charged both gauges will read abnormally high readings. This is causing a feedback pressure on the compressor, causing it to rattle or shake from the increased cylinder head pressure. System must be evacuated a weight specifications.
 - b. If air is introduced into the system during the charging process, it will introduce moisture that will cause ice to form in the refrigerant flow and will cause the compressor to rattle or growl under acceleration. System must be evacuated and re-charged to the exact weight specifications making sure to bleed any air from lines when introducing the refrigerant

B. SYSTEM NOT COOLING

1. There are numerous factors that can cause the cooling to be less than optimal.
 - a. **Improper charge in system** - Improper charging is the number one cause of system failure. The pressure readings should be taken before any determination can be made. High or low readings in direct proportion to the normal pressures (see sect. II) will tell you if the charge is too high or low. Excessive system pressure can also cause vibrations and whistling noise from the expansion valve and refrigerant lines.
 - B. **Heater control valve installation** - Installing the heater control valve in the incorrect hose will allow water to collect in the unit. **The heater control is a directional valve; make sure the water flow is with the direction of the arrow.** As the engine heats up the water transfers the heat to the coil, thus overpowering the a/c coil. A leaking or faulty valve will have a more pronounced affect on the unit's cooling ability. Installing the valve improperly (such as having the flow reversed) will allow water to flow through, thus inhibiting cooling. Check for heat transfer by disconnecting hosed from the system completely. By running down the road with the hosed looped back through the motor, you eliminate the possibility of heat transfer to the unit. Move or replace the valve if necessary.
 - C. **Evaporator freezing** - Freezing can occur both externally and internally on an evaporator core. **External freeze-up** occurs when the coil cannot effectively displace the condensation on the outsides of the fins and the water forms to ice (the evaporator core resembles a block of solid ice) it restricts the flow of air that can pass through it, which gives the illusion of the air not functioning. The common cause of external freezing is the setting of the thermostat and the presence of high humidity in the passenger compartment. All the door and window seals should be checked in the event of constant freeze-up. A thermostat is provided with all units to control the cycling of the compressor. **The rotary-type thermostat should be turned all of the way clockwise and then turned back counter clockwise an eight of a turn. The lever type thermostat should be back away from the cold position slightly.**

Internal freeze-up occurs when there is too much moisture inside the system. The symptoms of internal freeze-up often surface after extended highway driving. The volume of air stays constant, but the temperature of the air gradually rises. When this freezing occurs the low side pressure will drop, eventually going into a vacuum. At this point, the system should be checked by a professional who will evacuate the system and charge the drier.

d. **Inadequate airflow to condenser** - The condenser works best in front of the radiator with a large supply of fresh air. Abnormally high pressure will result from improper airflow. Check the airflow requirements by placing a large capacity fan in front of the condenser, and running cool water over the surface. If the pressure drops significantly, this will indicate the need for better airflow.

e. **Incorrect or inadequate condenser capacity** - Incorrect condenser capacity will cause abnormally high head pressure. Vintage Air recommends at least 300 cubic inches of fin area on a double-pass (two rows of tubes) condenser. (This can be measured by multiplying the height times the width times the thickness.) This rule only applies to the tube and fin style, the efficiency of the superflow design allows the use of a smaller area. A quick test that can be performed is to run cool water over the condenser while the system is operating, if the pressure decreases significantly, it is likely a airflow or capacity problem.

f. **Expansion valve failure** - An expansion valve failure is generally caused by dirt or debris entering the system during assembly. If an expansion valve fails it will be indicated by abnormal gauge readings. A valve that is blocked will be indicated by the high side that is usually high, while the low side will be usually low or may even go into a vacuum. A valve that is stuck open will be indicated by both the high and low pressures rising to unusually high readings, seeming to move toward equal readings on the gauges.

g. **Restrictions in system** - A restriction in the cooling system will cause abnormal readings on the gauges. A high-side restriction (between the compressor and the drier inlet) will be indicated by the discharge gauges reading excessively high.

These simple tests can be performed by a local shop and can help determine the extent of the system's problem. ***If further assistance is needed, our technical line is (210) 654-7171.*** If you have performed the initial test, please document results and readings before calling our technical line, it will help us solve the problem faster.