

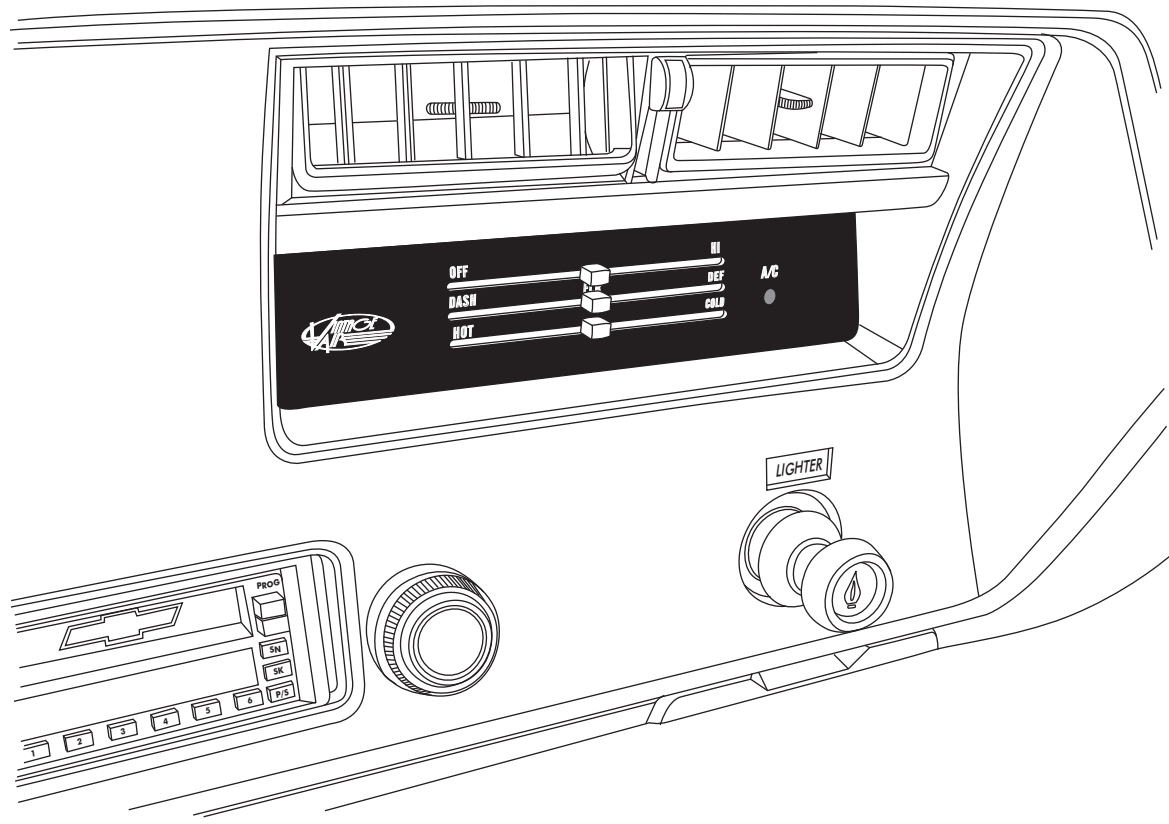

# 1970-72 CHEVELLE

CONTROL PANEL CONVERSION KIT

473072





## ***Table of Contents***

### PAGES

1. COVER
2. TABLE OF CONTENTS
3. PACKING LIST/ PARTS DISCLAIMER
4. REMOVING OEM CONTROL PANEL
5. CONTROL PANEL & CONTROL HARNESS INSTALLATION
6. WIRING DIAGRAM
7. OPERATION OF CONTROLS
8. CONTROL PANEL KIT PACKING LIST



CONTROL KIT  
473072

CONTROL KIT PACKING LIST

No.	QTY.	PART No.	DESCRIPTION
1.	1	473069	1970-72 CHEVELLE CNTRL PNL ASM
2.	1	232007-VUR	GEN IV UNIVERSAL CONTROL HARNESS (TYPE C)

**\*\* BEFORE BEGINNING INSTALLATION OPEN ALL PACKAGES AND CHECK CONTENTS OF SHIPMENT. PLEASE REPORT ANY SHORTAGES DIRECTLY TO VINTAGE AIR WITHIN 15 DAYS. AFTER 15 DAYS, VINTAGE AIR WILL NOT BE RESPONSIBLE FOR MISSING OR DAMAGED ITEMS.**

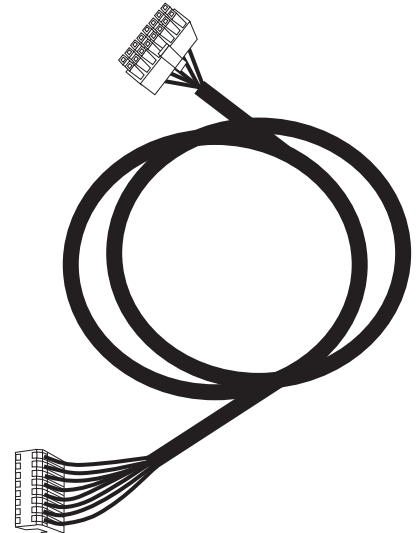
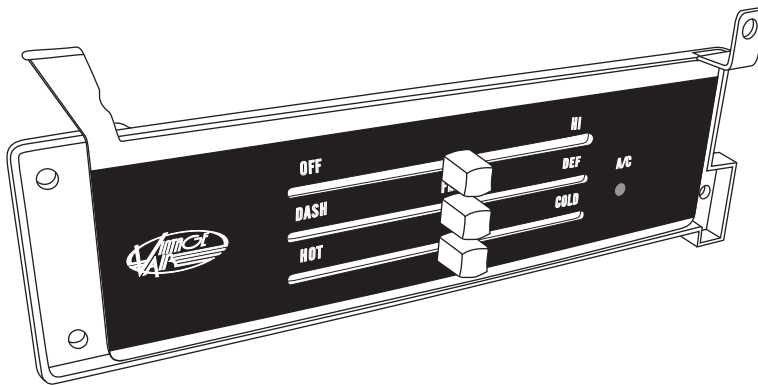

**NOTE: IMAGES MAY NOT DEPICT ACTUAL PARTS AND QUANTITIES. REFER TO PACKING LIST FOR ACTUAL PARTS AND QUANTITIES**



## 1970-72 CHEVELLE CONTROL PANEL CONVERSION KIT INSTRUCTIONS

### REMOVING OEM CONTROL PANEL

**NOTE:** REMOVAL OF DASHBOARD REQUIRED TO INSTALL THE CONTROL PANEL. VINTAGE AIR RECOMMENDS THAT YOU UTILIZE THE FACTORY SERVICE MANUAL WHEN YOU DISASSEMBLE AND REASSEMBLE THE DASHBOARD.

- DISCONNECT BATTERY GROUND CABLE.
- REMOVE THE DASH PAD BY REMOVING (6) OEM SCREWS.(RETAIN)
- LOWER STEERING COLUMN, PROTECT STEERING COLUMN WITH A CLOTH.
- DISCONNECT ALL WIRE AND CABLES FROM INSTRUMENT PANEL, SPEEDOMETER, CONTROL PANEL, AND RADIO.
- REMOVE CONTROL PANEL FROM INSTRUMENT PANEL.

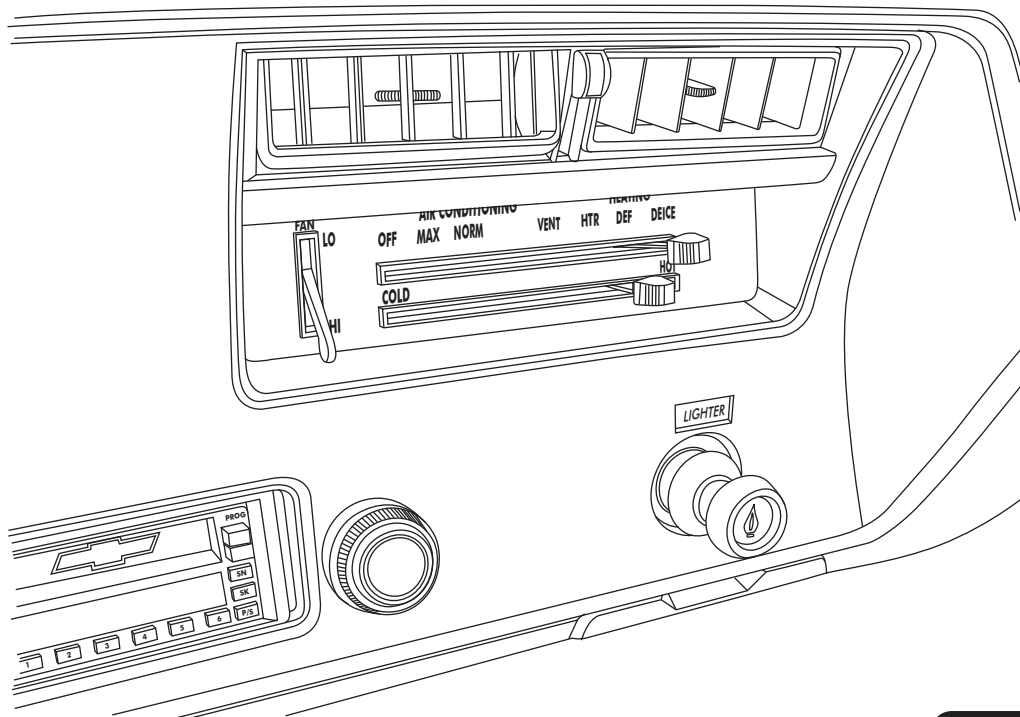
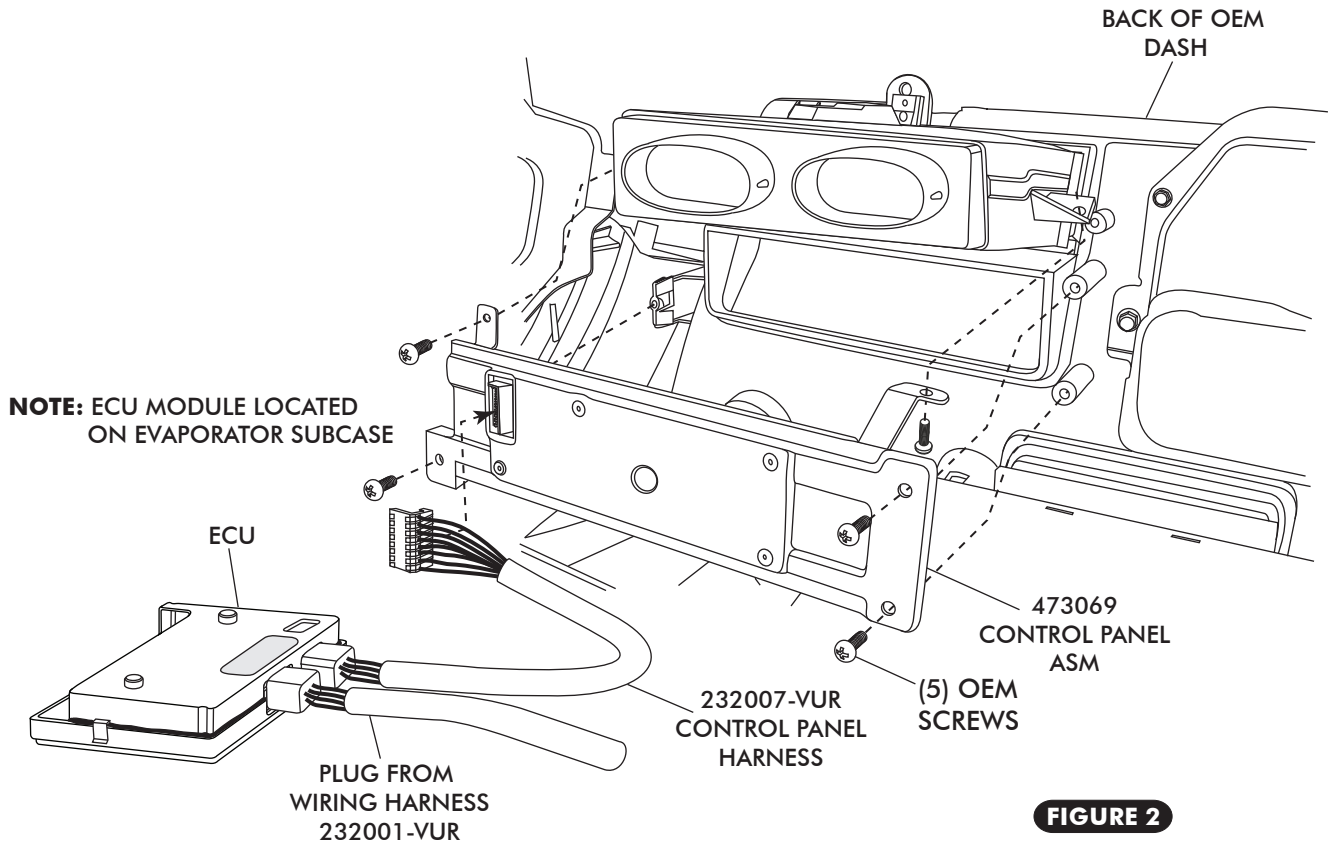

FIGURE 1

**CONTROL PANEL AND CONTROL HARNESS INSTALLATION**

- INSTALL CONTROL PANEL ASM TO BACK SIDE OF INSTRUMENT PANEL AS SHOWN IN FIGURE 2 BELOW.
- SECURE THE CONTROL PANEL ASM TO INSTRUMENT PANEL USING OEM SCREWS AS SHOWN IN FIGURE 2 BELOW.
- PLUG THE CONTROL PANEL HARNESS INTO ECU AS SHOWN IN FIGURE 2 BELOW. PLUG THE OPPOSITE END OF THE HARNESS INTO THE CONTROL PANEL PC BOARD AS SHOWN IN FIGURE 2 BELOW.



**FINAL STEPS**

- REINSTALL ALL PREVIOUSLY REMOVED ITEMS ( INSTRUMENT PANEL, RADIO AND WIRING)
- REINSTALL DASH PAD USING THE (6) OEM SCREWS.

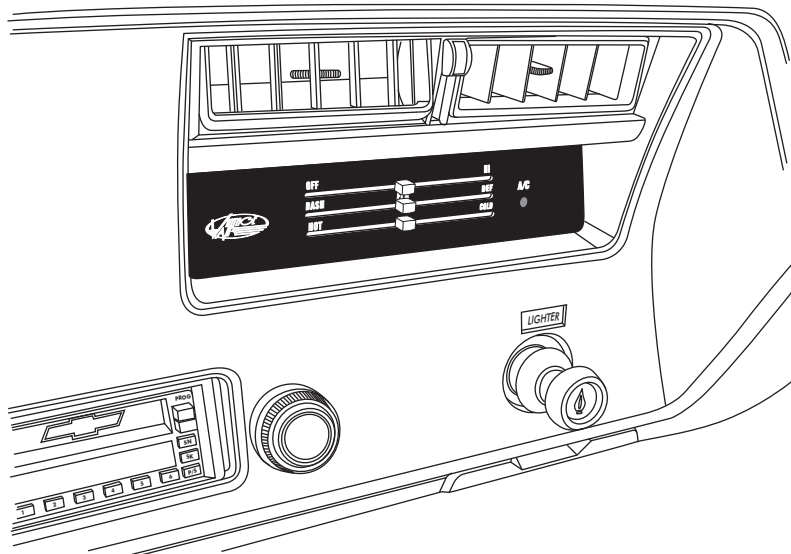



WIRING DIAGRAM

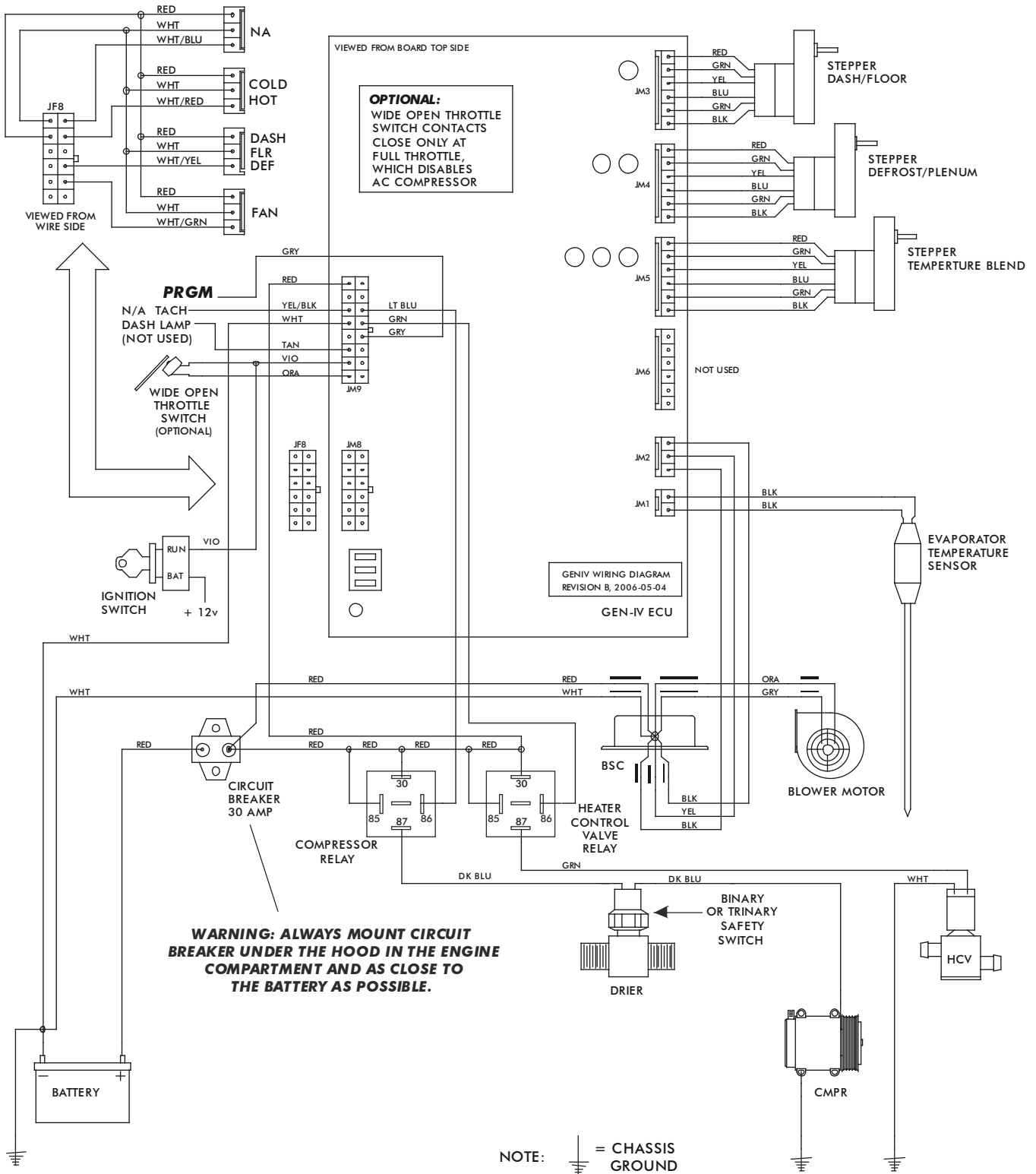



## OPERATION OF CONTROLS

**NOTE: WHEN BATTERY POWER IS FIRST CONNECTED TO THE ECU, THE COMPUTER GOES THROUGH AN INITIALIZATION SEQUENCE. THIS INITIALIZATION MAY TAKE UP TO 30 SECONDS. DURING INITIALIZATION THE BLOWER WILL NOT OPERATE, BUT THE DOORS INSIDE THE UNIT WILL BE OPERATING. A LOW BATTERY OR DISCONNECTING THE BATTERY MAY ALSO TRIGGER RE-INITIALIZATION. DURING START UP, A LOW BATTERY MAY DROP BELOW 7 VOLTS, TRIGGERING RE-INITIALIZATION.**

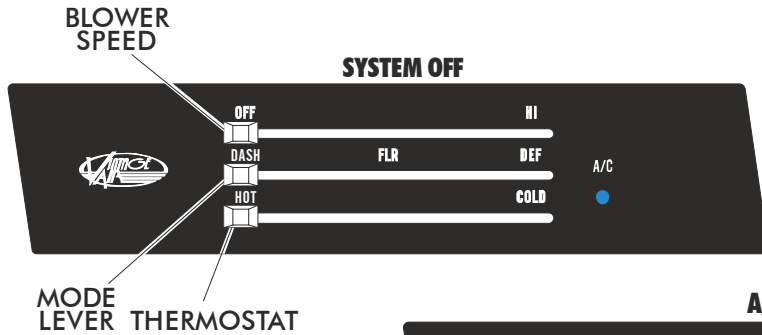

BLOWER SPEED

### SYSTEM OFF

MODE LEVER THERMOSTAT

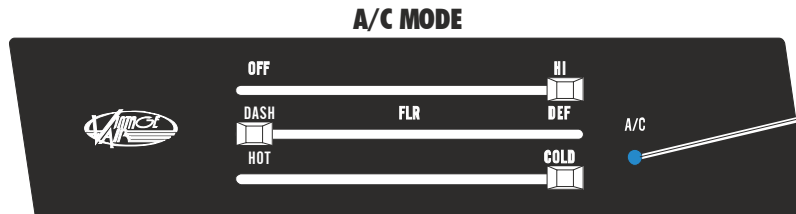

### A/C MODE

BLUE AC INDICATOR LIGHT

**BLOWER SPEED**  
THIS LEVER CONTROLS THE BLOWER SPEED, FROM OFF TO HI

**A/C THERMOSTAT LEVER**  
IN A/C MODE SLIDE THE THERMOSTAT LEVER ALL THE WAY RIGHT TO THE COLD POSITION, FOR MAXIMUM COOLING. BLUE AC INDICATOR LIGHT WILL COME ON ONLY WHEN AC COMPRESSOR IS ENGAGED (**SLIDE LEVER LEFT OR RIGHT TO ADJUST DESIRED TEMPERATURE**)

**MODE LEVER**  
SLIDE THE LEVER TO THE "DASH" POSITION

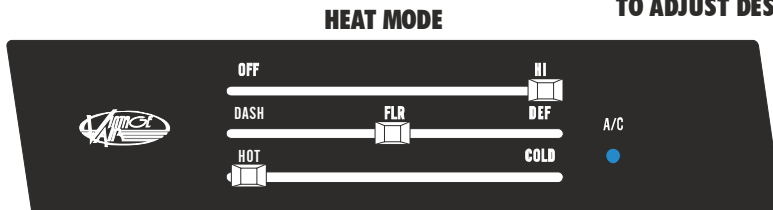

### HEAT MODE

**A/C THERMOSTAT LEVER**  
IN HEAT MODE SLIDE THE THERMOSTAT LEVER ALL THE WAY TO THE LEFT TO THE HOT POSITION, FOR MAXIMUM HEATING (**SLIDE LEVER LEFT OR RIGHT TO ADJUST DESIRED TEMPERATURE**)

**MODE LEVER**  
SLIDE THE LEVER TO THE "FLR" POSITION (SLIDE THE LEVER TO THE LEFT OR RIGHT, TO ADJUST DESIRED DASH/FLR/DEF LOCATION)

### DEFROST MODE



**A/C THERMOSTAT LEVER**  
IN DEF MODE SLIDE THE THERMOSTAT LEVER ALL THE WAY TO THE LEFT TO THE HOT POSITION, FOR MAXIMUM HEATING (**SLIDE LEVER LEFT OR RIGHT TO ADJUST DESIRED TEMPERATURE**)

**MODE LEVER**  
SLIDE THE LEVER TO THE "DEF" POSITION



**CONTROL KIT PACKING LIST**

**CONTROL KIT  
473072**

No.	QTY.	PART No.	DESCRIPTION
1.	1	473069	1970-72 CHEVELLE CNTRL PNL ASM
2.	1	232007-VUR	GEN IV UNIVERSAL CONTROL HARNESS (TYPE C)

CHECKED BY: \_\_\_\_\_  
 PACKED BY: \_\_\_\_\_  
 DATE: \_\_\_\_\_

**\*\* BEFORE BEGINNING INSTALLATION OPEN ALL PACKAGES AND CHECK CONTENTS OF SHIPMENT. PLEASE REPORT ANY SHORTAGES DIRECTLY TO VINTAGE AIR WITHIN 15 DAYS. AFTER 15 DAYS, VINTAGE AIR WILL NOT BE RESPONSIBLE FOR MISSING OR DAMAGED ITEMS.**

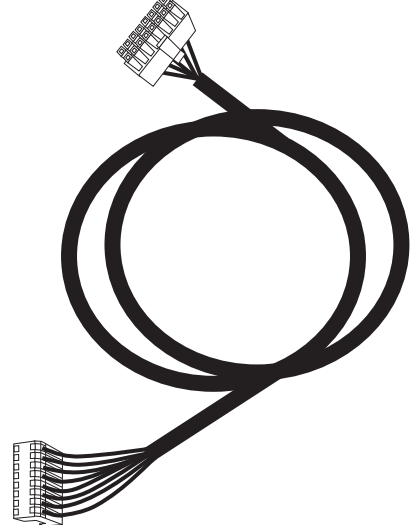
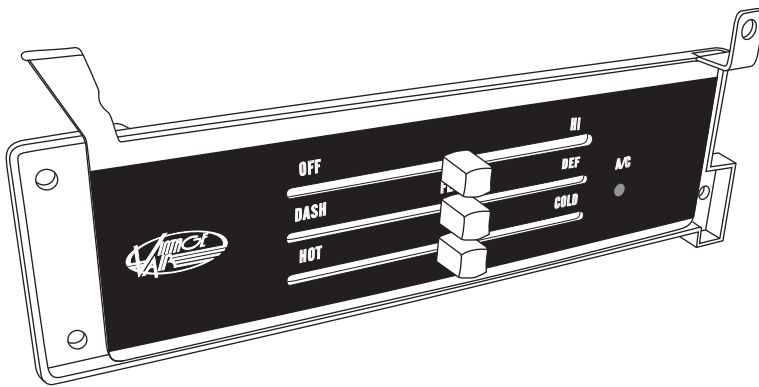

**NOTE: IMAGES MAY NOT DEPICT ACTUAL PARTS AND QUANTITIES.  
 REFER TO PACKING LIST FOR ACTUAL PARTS AND QUANTITIES**