

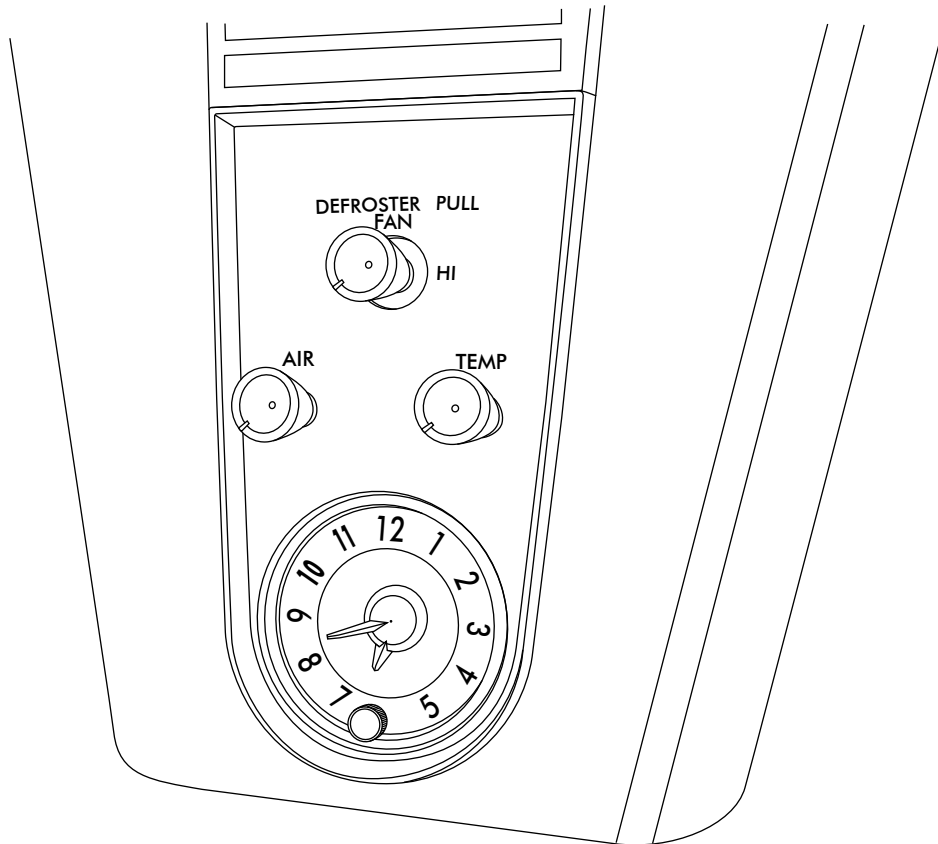

an ISO 9001: 2008 Registered Company

# 1961-62 CORVETTE

CONTROL PANEL  
CONVERSION KIT  
473160



18865 GOLL ST. - SAN ANTONIO, TX. - 78266 ph.210-654-7171 - fax 210-654-3113



## Table of Contents

### PAGES

1. COVER
2. TABLE OF CONTENTS
3. PACKING LIST/ PARTS DISCLAIMER
4. OEM CENTER CONSOLE HEATER CONTROL BEZEL
5. ROTARY POT INSTALLATION
6. FINAL STEPS
7. CONTROL PANEL CALIBRATION PROCEDURE
8. CONTROL PANEL CALIBRATION PROCEDURE CONT.
9. WIRING DIAGRAM
10. OPERATION OF CONTROLS
11. CONTROL PANEL KIT PACKING LIST



**CONTROL KIT  
473160**

No	QTY	PART No.	DESCRIPTION
1.	3	246018-0	ROTARY POT ASM
2.	1	232002-VUA	GEN IV UNIVERSAL CONTROL HARNESS
3.	3	497003	KNOB, ALUMINUM FLUTED
4.	2	186011	WASHER .625 OD x .281 ID
5.	5	21301-VUP	4" TIE WRAP
6.	1	231520	GROUND WIRE
7.	3	18399-VUB	4-40 X 3/16 SOCKET SET SCREW
8.	1	117000	ADAPTER, 58-62 CORVETTE CONTROL POT UPPER
9.	2	117001	ADAPTER, 58-62 CORVETTE CONTROL POT LOWER

**\*\* BEFORE BEGINNING INSTALLATION OPEN ALL PACKAGES AND CHECK CONTENTS OF SHIPMENT. PLEASE REPORT ANY SHORTAGES DIRECTLY TO VINTAGE AIR WITHIN 15 DAYS. AFTER 15 DAYS, VINTAGE AIR WILL NOT BE RESPONSIBLE FOR MISSING OR DAMAGED ITEMS.**

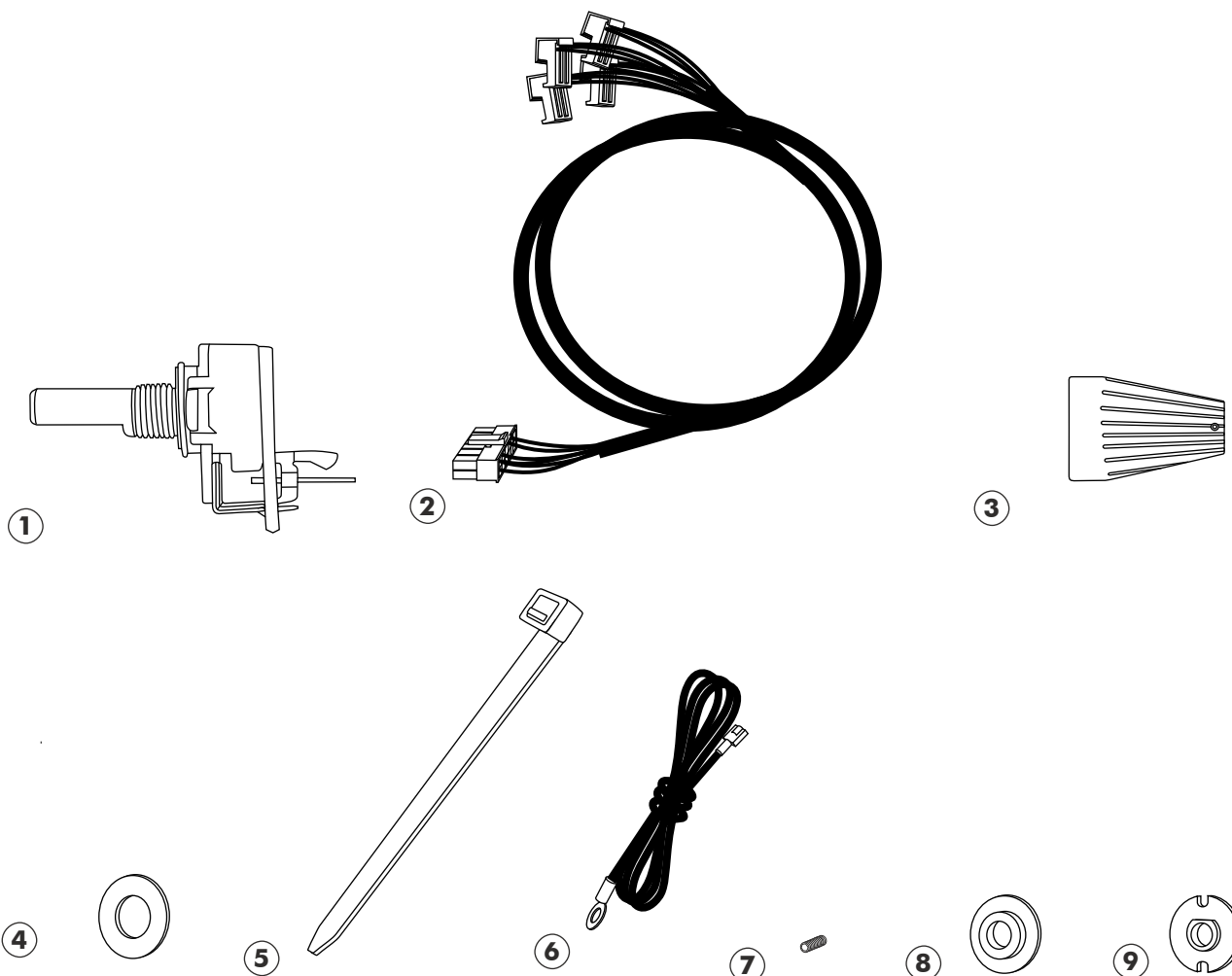



## ROTARY POT CONTROL CONVERSION INSTRUCTIONS FOR 1961-62 CORVETTE

### OEM CENTER CONSOLE HEATER CONTROL BEZEL

- DISCONNECT CABLES, WIRES FROM BACK OF CONTROL BEZEL.
- REMOVE OEM CONTROL BEZEL.

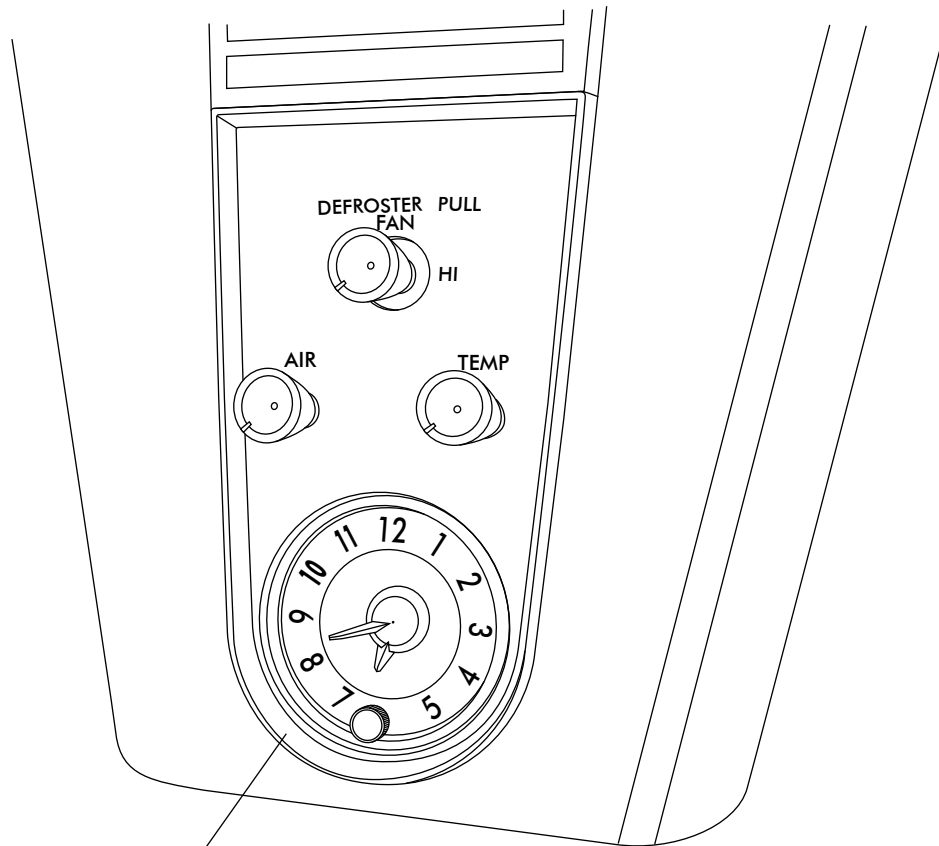

OEM CENTER  
CONSOLE HEATER  
CONTROL BEZEL



## ROTARY POT INSTALLATION

- CUT 1/8" SLOT IN OEM DEFROSTER PULL FAN HOLE IN CONTROL BEZEL. SEE BELOW.
- LOCATE THE (3) ROTARY POT ASSEMBLIES, AND INSTALL IN OEM CONTROL BEZEL AS SHOWN BELOW.
- TIE WRAP WIRES TO ROTARY POTS AS SHOWN.
- INSTALL CONTROL KNOB AS SHOWN BELOW.

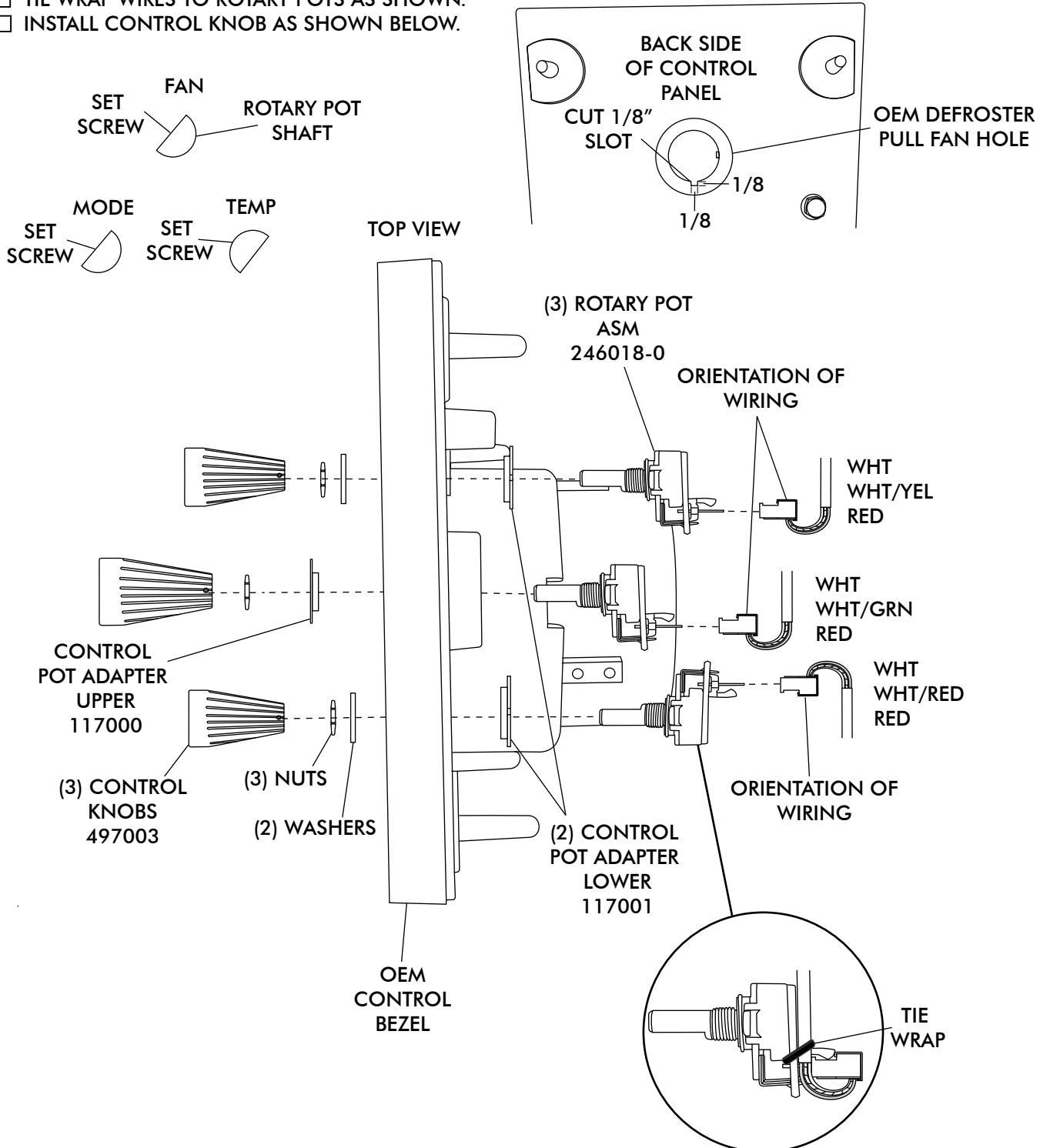



## FINAL STEPS

- PLUG THE WIRING HARNESS INTO THE ECU MODULE ON SUB CASE. SEE BELOW.
- WIRE ACCORDING TO WIRING DIAGRAM ON PAGE 9.
- TO CALIBRATE THE CONTROLS FOLLOW THE CALIBRATION PROCEDURES ON PAGES 7 & 8.

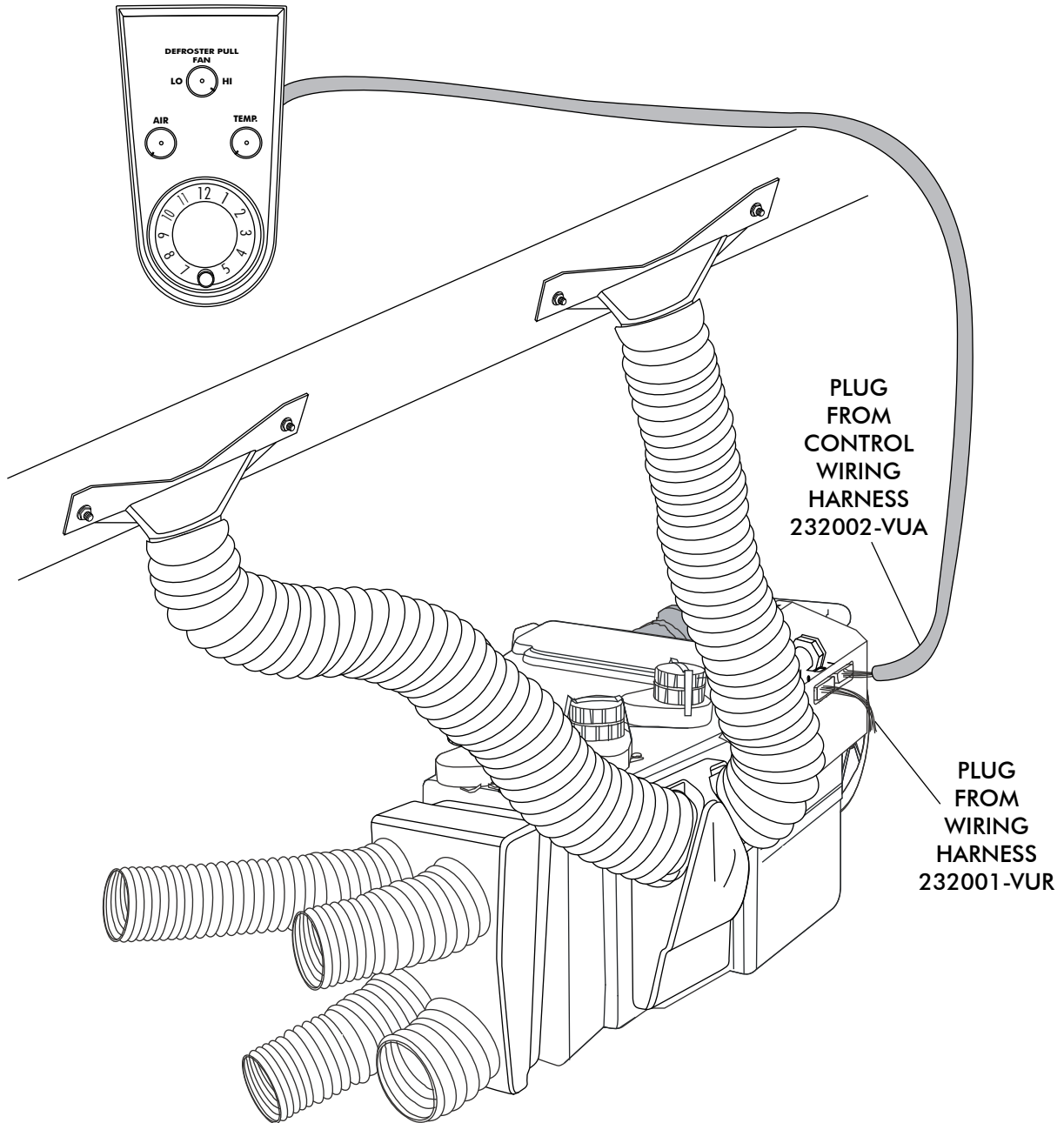



## CONTROL PANEL CALIBRATION PROCEDURE

ON VINTAGE AIR GEN 4 SYSTEMS USING FACTORY CONTROLS, IT IS NECESSARY TO CALIBRATE THE SYSTEM TO YOUR SPECIFIC CONTROL PANEL. THIS PROCEDURE ENSURES THAT THE STROKE OF YOUR CONTROL PANEL LEVERS OR KNOBS IS TRANSLATED INTO PRECISE CONTROL OF THE FAN SPEED, TEMPERATURE BLEND, AND MODE DOOR POSITION. PLEASE CAREFULLY READ AND UNDERSTAND THESE PROCEDURES BEFORE BEGINNING. THE PROCEDURE MAY BE REPEATED AS MANY TIMES AS NECESSARY TO GET IT RIGHT.

IN PREPARATION FOR CALIBRATION, YOU WILL NEED TO ATTACH THE SUPPLIED WHITE GROUND JUMPER WIRE TO A SUITABLE CHASSIS GROUND. THIS JUMPER WIRE MUST BE EASILY CONNECTED TO THE GRAY PROGRAMMING WIRE LOCATED IN THE MAIN GEN 4 WIRING HARNESS NEXT TO THE RELAYS. DURING THE CALIBRATION PROCEDURE, YOU WILL CONNECT THE WHITE JUMPER TO THE GRAY PROGRAM WIRE WHICH WILL "TEACH" THE GEN 4 ECU THE UPPER LIMITS OF THE CONTROL LEVERS OR KNOBS. THE BLOWER WILL MOMENTARILY CHANGE SPEEDS, SIGNALING THAT THE UPPER LIMITS HAVE BEEN "LEARNED". YOU WILL MOVE THE LEVERS OR KNOBS TO OPPOSITE EXTREME POSITIONS OF THEIR TRAVEL AND THEN DISCONNECT THE WHITE JUMPER. THE BLOWER WILL AGAIN CHANGE SPEEDS, SIGNALING THAT THE LOWER LIMITS HAVE BEEN LEARNED AND THAT THE CALIBRATION PROCEDURE IS COMPLETE.

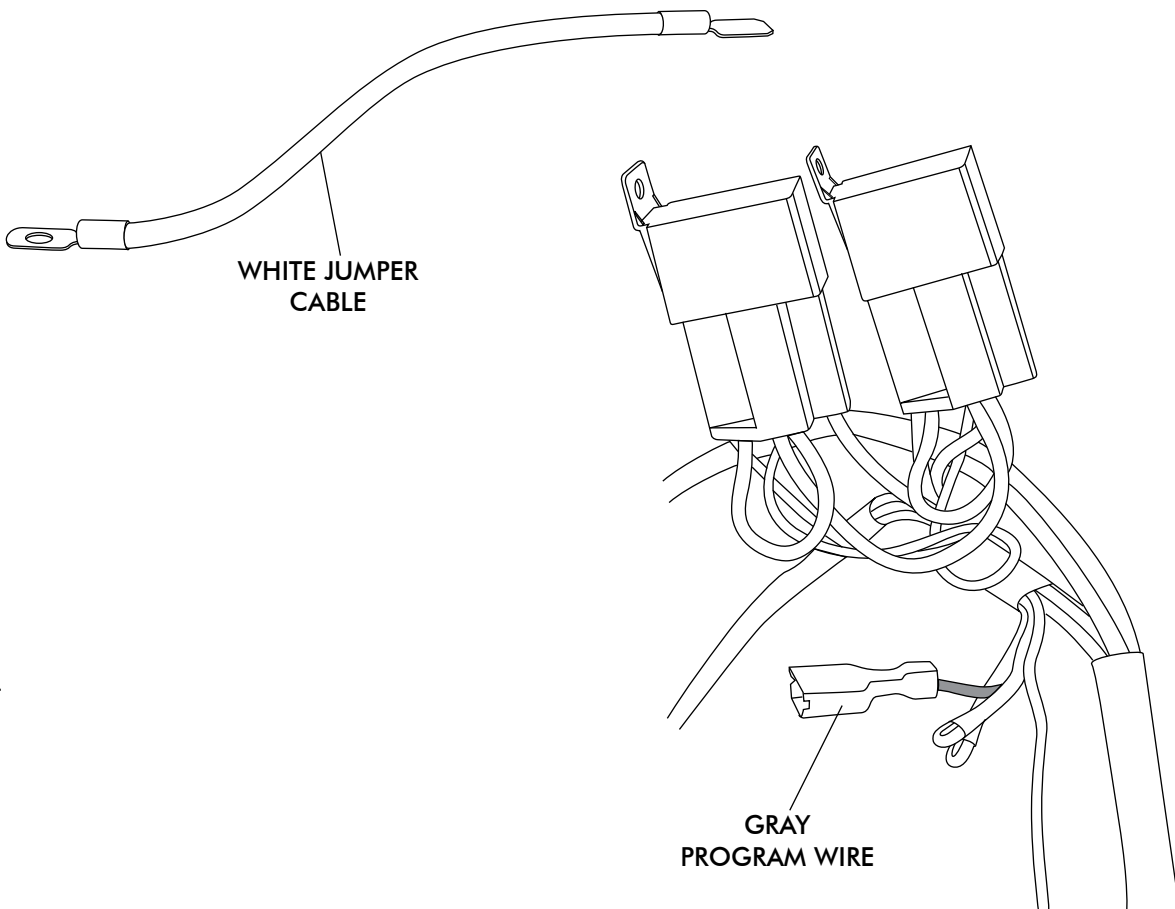



## CONTROL PANEL CALIBRATION PROCEDURE CONT.

- TURN THE IGNITION SWITCH ON (DO NOT START THE ENGINE)

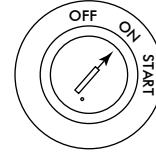

- MOVE THE FAN SWITCH (IF USED) AND CONTROL KNOBS TO THE POSITION SHOWN.

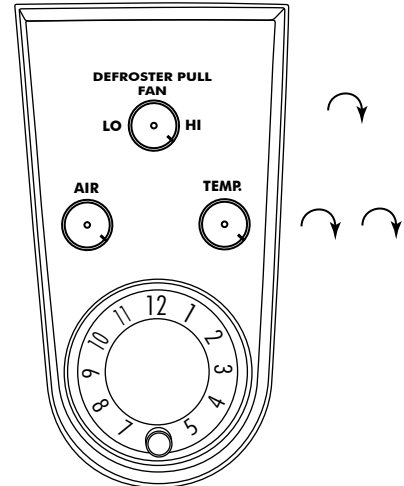

- CONNECT THE WHITE JUMPER WIRE TO THE GRAY PROGRAM WIRE. WAIT FOR THE BLOWER SPEED TO CHANGE. (APPROXIMATELY 5 SECONDS)

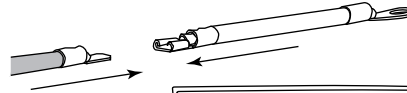

- MOVE THE FAN SWITCH AND CONTROL KNOBS TO THE POSITIONS SHOWN

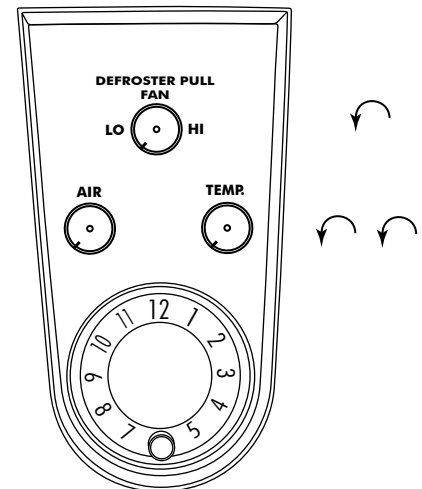

- DISCONNECT THE WHITE JUMPER WIRE FROM THE GRAY PROGRAM WIRE. THE BLOWER SPEED WILL CHANGE, INDICATING COMPLETION OF THE CALIBRATION PROCEDURE.

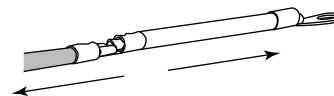

- CONFIRM PROPER OPERATION OF CONTROLS. REPEAT PROCEDURE IF NECESSARY. **WHEN FINISHED, TAPE OVER PROGRAM WIRE CONNECTOR WITH ELECTRICAL TAPE TO PREVENT ACCIDENTAL CONTACT WITH CHASSIS GROUND.**



# WIRING DIAGRAM

## 232006-VUR

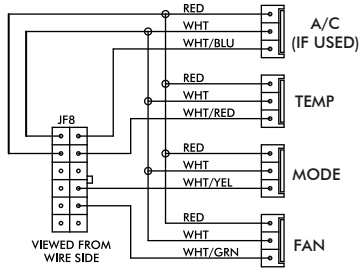

## 232007-VUR

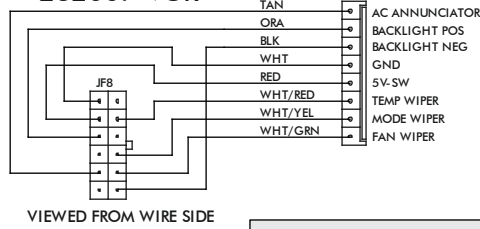

## 232002-VUA

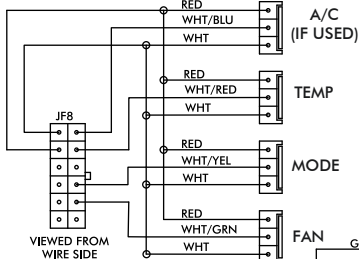

## GEN IV ECU

GEN IV WIRING DIAGRAM  
REV C, 11/24/2009

## PRE-WIRED

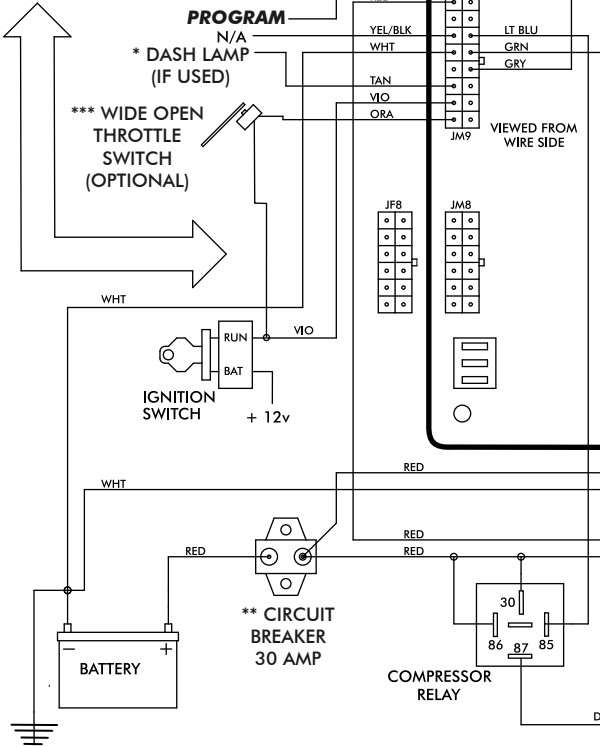
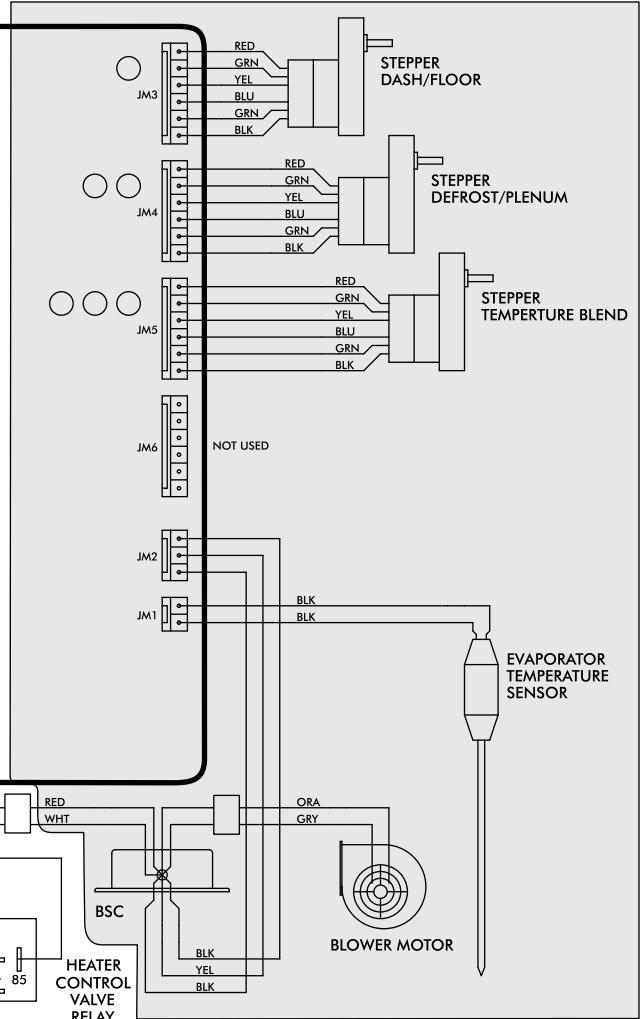

NOTE: = CHASSIS GROUND

\* DASH LAMP IS ONLY USED WITH TYPE C HARNESS

\*\* WARNING: ALWAYS MOUNT CIRCUIT BREAKER UNDER THE HOOD IN THE ENGINE COMPARTMENT AND AS CLOSE TO THE BATTERY AS POSSIBLE.

\*\*\* WIDE OPEN THROTTLE SWITCH CONTACTS CLOSE ONLY AT FULL THROTTLE, WHICH DISABLES AC COMPRESSOR.



## OPERATION OF CONTROLS

THE TEMPERATURE KNOB TOGGLES BETWEEN A/C AND HEAT MODES. FOR A/C MODE ROTATE THE TEMPERATURE KNOB ALL THE WAY LEFT. FOR HEAT MODE ROTATE THE KNOB ALL THE WAY TO THE RIGHT TO DISENGAGE THE COMPRESSOR, THEN MOVE THE KNOB TO SELECT DESIRED TEMPERATURE.

NOTE: EACH TIME THE SYSTEM TOGGLES BETWEEN MODES, THE BLOWER WILL MOMENTARILY CHANGE SPEEDS.

ALL SWITCHES ARE VARIABLE BETWEEN POSITIONS, SYSTEM WILL PERFORM A BLEND BETWEEN THE FUNCTIONS.

### BLOWER SPEED

THIS KNOB CONTROLS THE BLOWER SPEED, FROM OFF TO HI

### MODE KNOB

ROTATE THE KNOB TO THE LEFT TO DIRECT AIR FLOW TO THE DASH VENTS

### TEMPERATURE KNOB

IN A/C MODE ROTATE THE TEMPERATURE KNOB ALL THE WAY LEFT TO THE COLD POSITION TO ENGAGE COMPRESSOR. (ROTATE KNOB LEFT OR RIGHT TO ADJUST DESIRED TEMPERATURE)

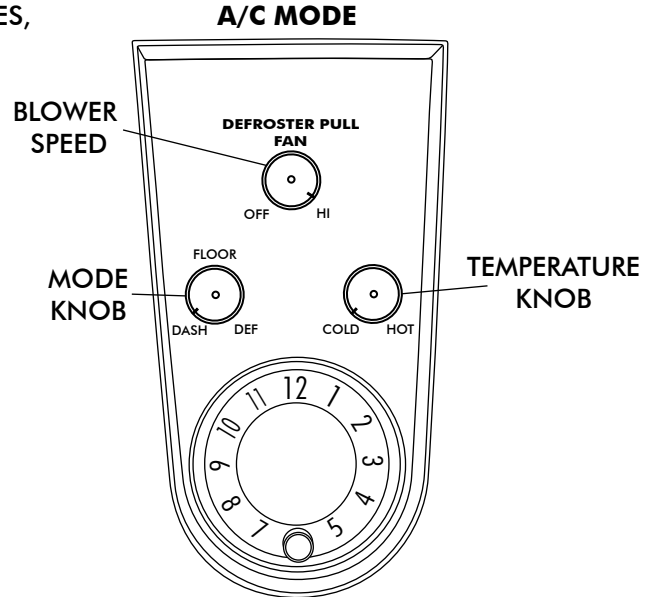

### HEAT MODE

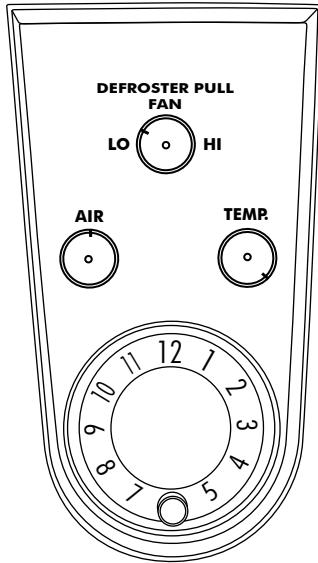

### BLOWER SPEED

ROTATE KNOB RIGHT TO DESIRED BLOWER SPEED FROM OFF TO HI.

### MODE KNOB

ROTATE THE KNOB TO THE CENTER TO DIRECT AIR FLOW TO THE FLOOR.

### TEMPERATURE KNOB

IN HEAT MODE ROTATE THE TEMPERATURE KNOB ALL THE WAY RIGHT TO THE HOT POSITION. (ROTATE KNOB LEFT OR RIGHT TO ADJUST DESIRED TEMPERATURE)

### DEFROST/ DE-FOG MODE

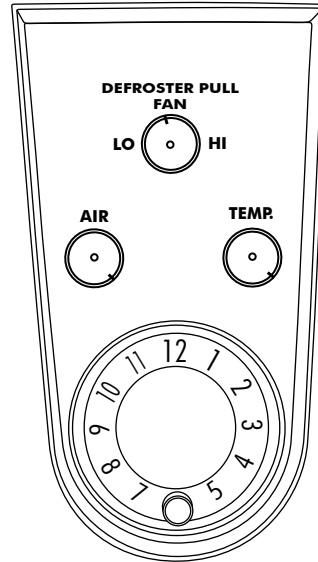

### BLOWER SPEED

ROTATE KNOB RIGHT TO DESIRED BLOWER SPEED FROM OFF TO HI.

### MODE KNOB

ROTATE THE KNOB TO THE RIGHT TO DIRECT AIR FLOW TO THE DEFROST VENTS.

### TEMPERATURE KNOB

ROTATE KNOB LEFT OR RIGHT TO ADJUST DESIRED TEMPERATURE. (COMPRESSOR IS AUTOMATICALLY ENGAGED)



**CONTROL KIT  
473160**

No	QTY	PART No.	DESCRIPTION	CHECK LIST
1.	3	246018-0	ROTARY POT ASM	_____
2.	1	232002-VUA	GEN IV UNIVERSAL CONTROL HARNESS	_____
3.	3	497003	KNOB, ALUMINUM FLUTED	_____
4.	2	186011	WASHER .625 OD x .281 ID	_____
5.	5	21301-VUP	4" TIE WRAP	_____
6.	1	231520	GROUND WIRE	_____
7.	3	18399-VUB	4-40 x 3/16 SOCKET SET SCREW	_____
8.	1	117000	ADAPTER, 58-62 CORVETTE CONTROL POT UPPER	_____
9.	2	117001	ADAPTER, 58-62 CORVETTE CONTROL POT LOWER	_____

CHECKED BY: \_\_\_\_\_  
 PACKED BY: \_\_\_\_\_  
 DATE: \_\_\_\_\_

