



an ISO 9001:2008 Registered Company

1966-67 CORVETTE

CONDENSER w/DRIER

021164

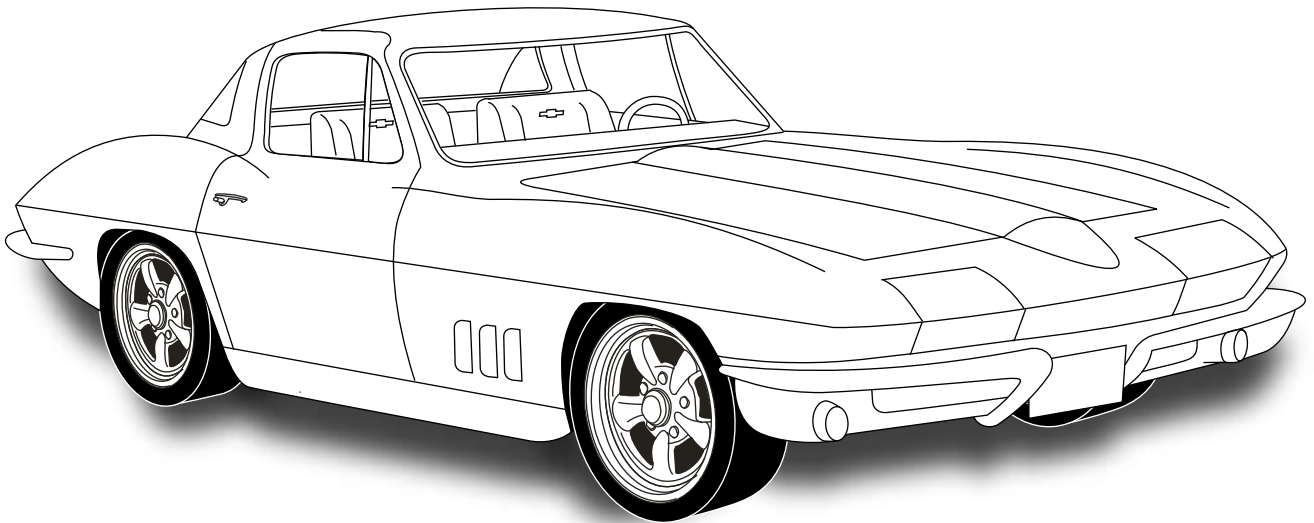



Table of Contents

PAGES

1. COVER
2. TABLE OF CONTENTS
3. PACKING LIST/PARTS DISCLAIMER
4. MOUNTING BRACKET INSTALLATION
5. MOUNTING BRACKET INSTALLATION CONT./DRIER INSTALLATION
6. CONDENSER & HARDLINE INSTALLATION
7. HARDLINE CLAMP & SAFETY SWITCH INSTALLATION
8. PACKING LIST



**CONDENSER KIT
021164**

No.	QTY.	PART No.	DESCRIPTION
1.	1	03767-VUC	14 X 24 PARALLEL FLOW COND.
2.	2	07113-VUB	DRIER CLAMP
3.	1	07321-VUC	DRIER
4.	1	644034	BRKT 66-67 VETTE COND TOP
5.	1	644038	BRKT 63-67 VETTE COND PASS SIDE BTM
6.	1	644039	BRKT 63-67 VETTE COND DR SIDE BTM
7.	1	644051	BRKT 14 3/4" TYPE 2 UNIVERSAL DRIER
8.	1	091081	HARDLINE 66-67 VETTE #6 DRIER/CORE
9.	1	091082	HARDLINE 66-67 VETTE #8 COND
10.	1	35130-VCG	HARDLINE 63-67 VETTE COND/DRIER
11.	8	18260-VUB	10-24 NUT w/STAR WASHER
12.	8	18249-VUB	10-24 x 3/8" PAN HEAD SCREW
13.	3	33857-VUF	#6 O-RING
14.	1	33858-VUF	#8 O-RING
15.	2	18247-VUB	#10 x 1/2" HEX SCREW
16.	1	11079-VUS	MALE BINARY SWITCH
17.	1	23135-VUW	COMPRESSOR LEAD
18.	1	31600-VUD	#2 ADEL CLAMP
19.	1	18250-VUB	10-32 x 1/2" PAN HEAD SCREW
20.	1	18251-VUB	10-32 NUT w/STAR WASHER

**** BEFORE BEGINNING INSTALLATION OPEN ALL PACKAGES AND CHECK CONTENTS OF SHIPMENT. PLEASE REPORT ANY SHORTAGES DIRECTLY TO VINTAGE AIR WITHIN 15 DAYS. AFTER 15 DAYS, VINTAGE AIR WILL NOT BE RESPONSIBLE FOR MISSING OR DAMAGED ITEMS.**

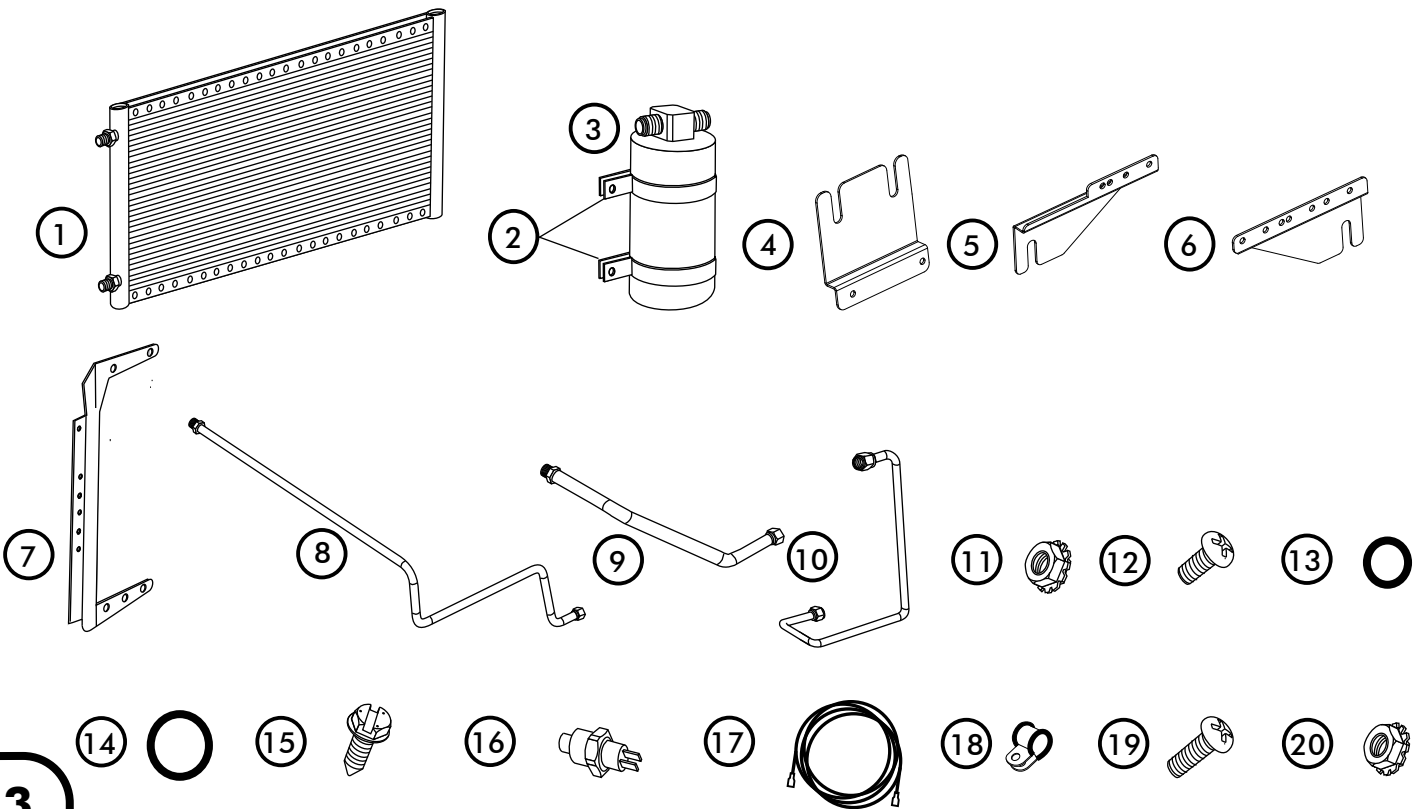



NOTE: MARK HINGE LOCATION ON HOOD AND REMOVE HOOD. REMOVE HOOD PROP.

MOUNTING BRACKET INSTALLATION

- INSTALL MOUNTING BRACKETS ON TO CONDENSER USING 10-24 x 3/8" PAN HEAD SCREWS AND 10-24 NUTS w/STAR WASHERS AS SHOWN BELOW.

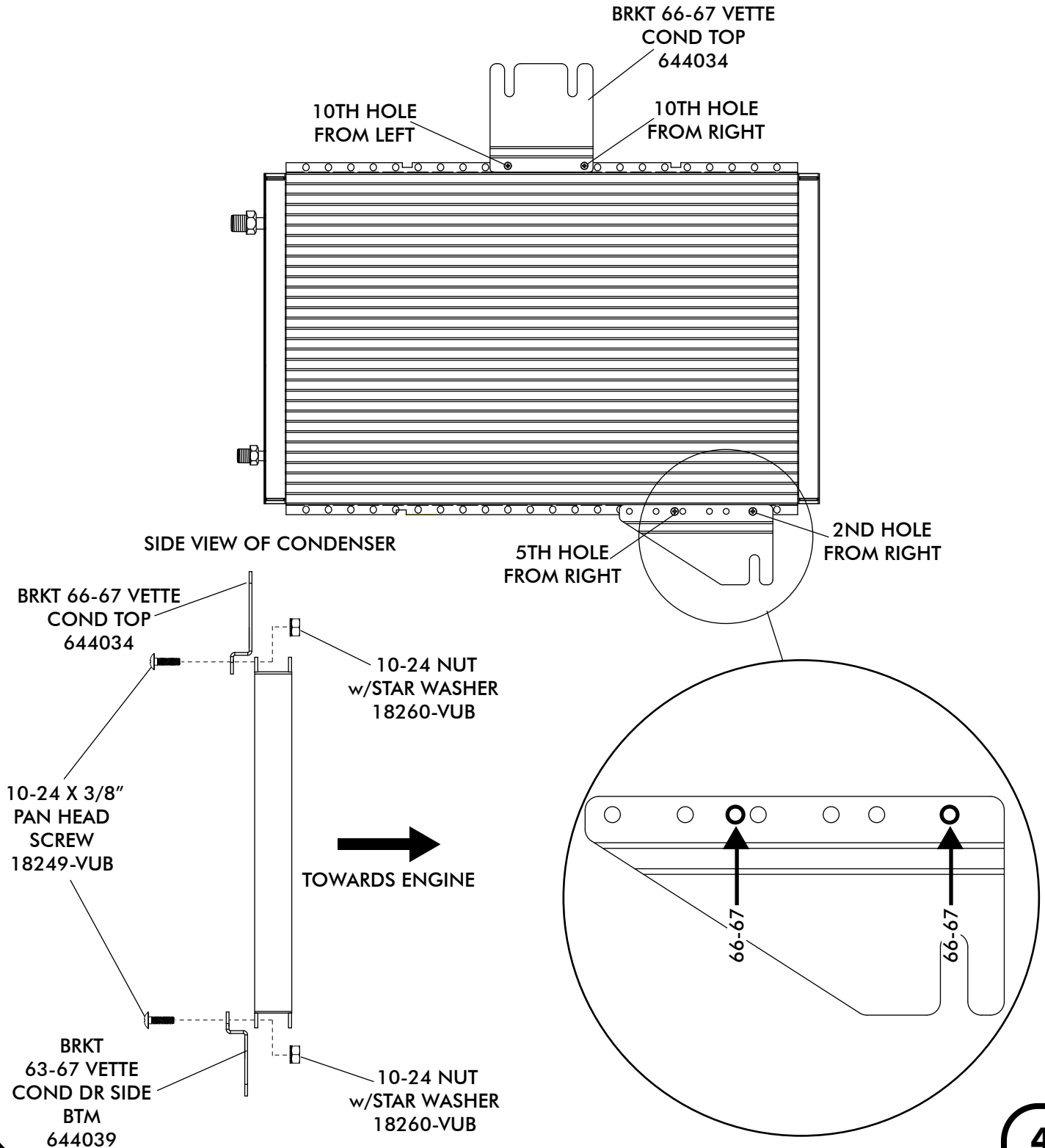



MOUNTING BRACKET INSTALLATION CONT./DRIER INSTALLATION

- INSTALL MOUNTING BRACKETS ON TO CONDENSER USING 10-24 x 3/8" PAN HEAD SCREWS AND 10-24 NUTS w/STAR WASHERS AS SHOWN BELOW. NOTE: BRACKETS MOUNT THROUGH THE 1ST AND 3RD HOLES ON THE TOP AND 2ND AND 3RD HOLES ON THE BOTTOM OF THE CONDENSER.
- INSTALL DRIER CLAMPS ON DRIER AS SHOWN.
- USING (2) #10 x 1/2" SHEETMETAL SCREWS INSTALL DRIER ON BRACKET IN THE 4TH AND 6TH HOLES FROM THE TOP.

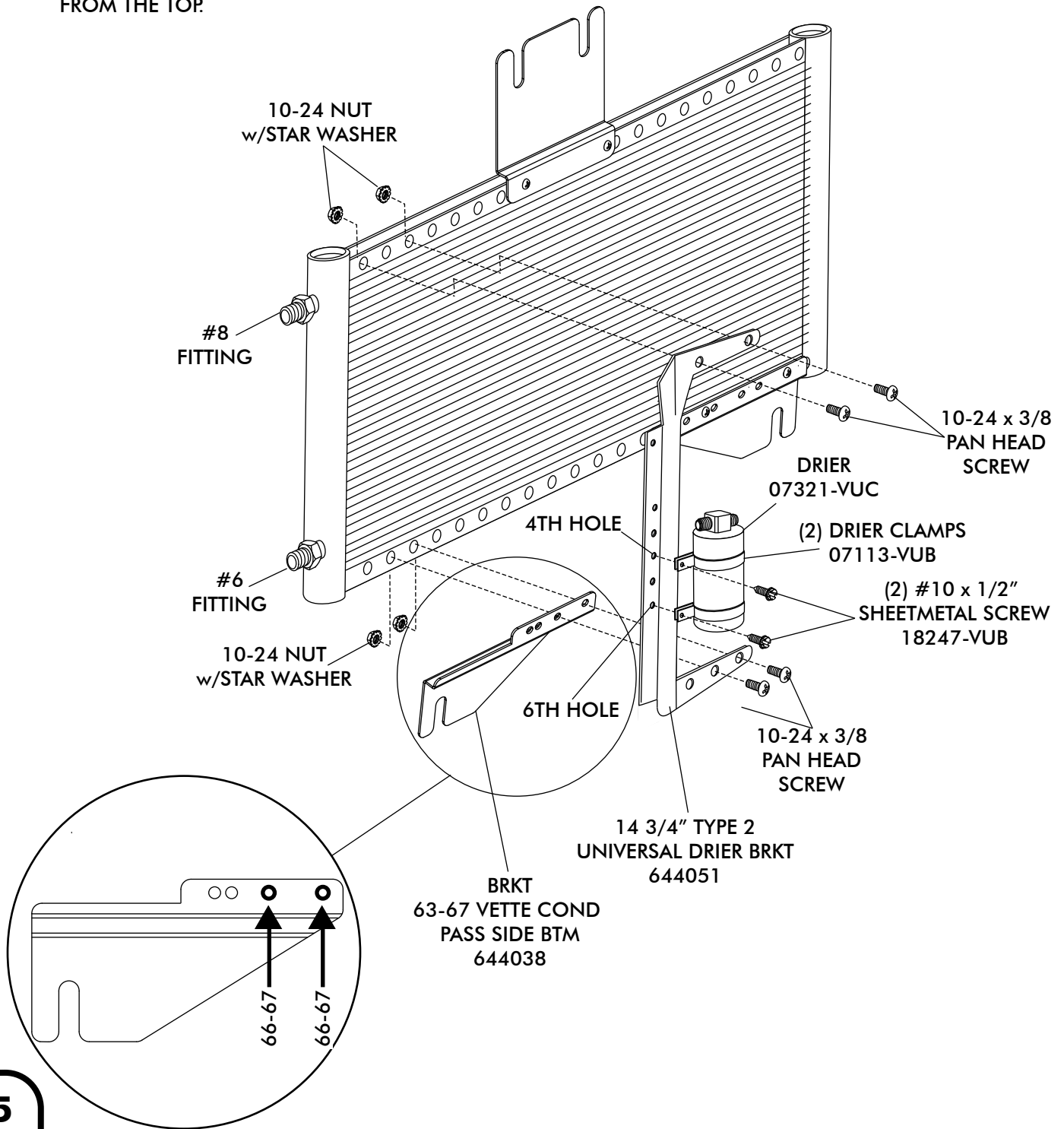



CONDENSER & HARDLINE INSTALLATION

- LUBRICATE (2) #6 O-RING (SEE FIGURE 1) AND INSTALL THE #6 COND/DRIER HARDLINE AS SHOWN.

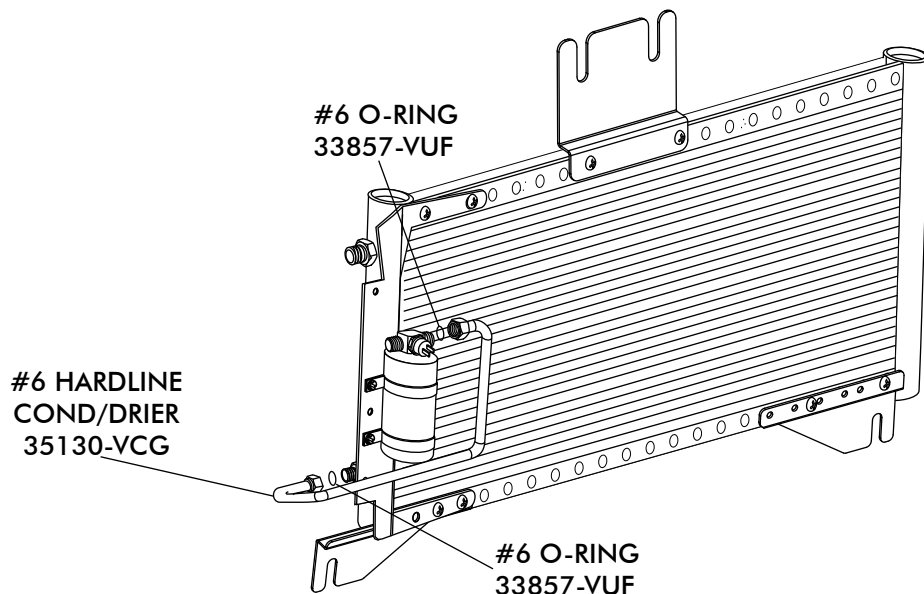

- INSTALL CONDENSER IN FRONT OF CORE SUPPORT AS SHOWN BELOW, USING OEM BOLTS.
- LUBRICATE #6 O-RING AND INSTALL THE #6 DRIER/CORE HARDLINE. LUBRICATE #8 O-RING AND INST THE #8 COND HARDLINE AS SHOWN. (SEE FIGURE 1)

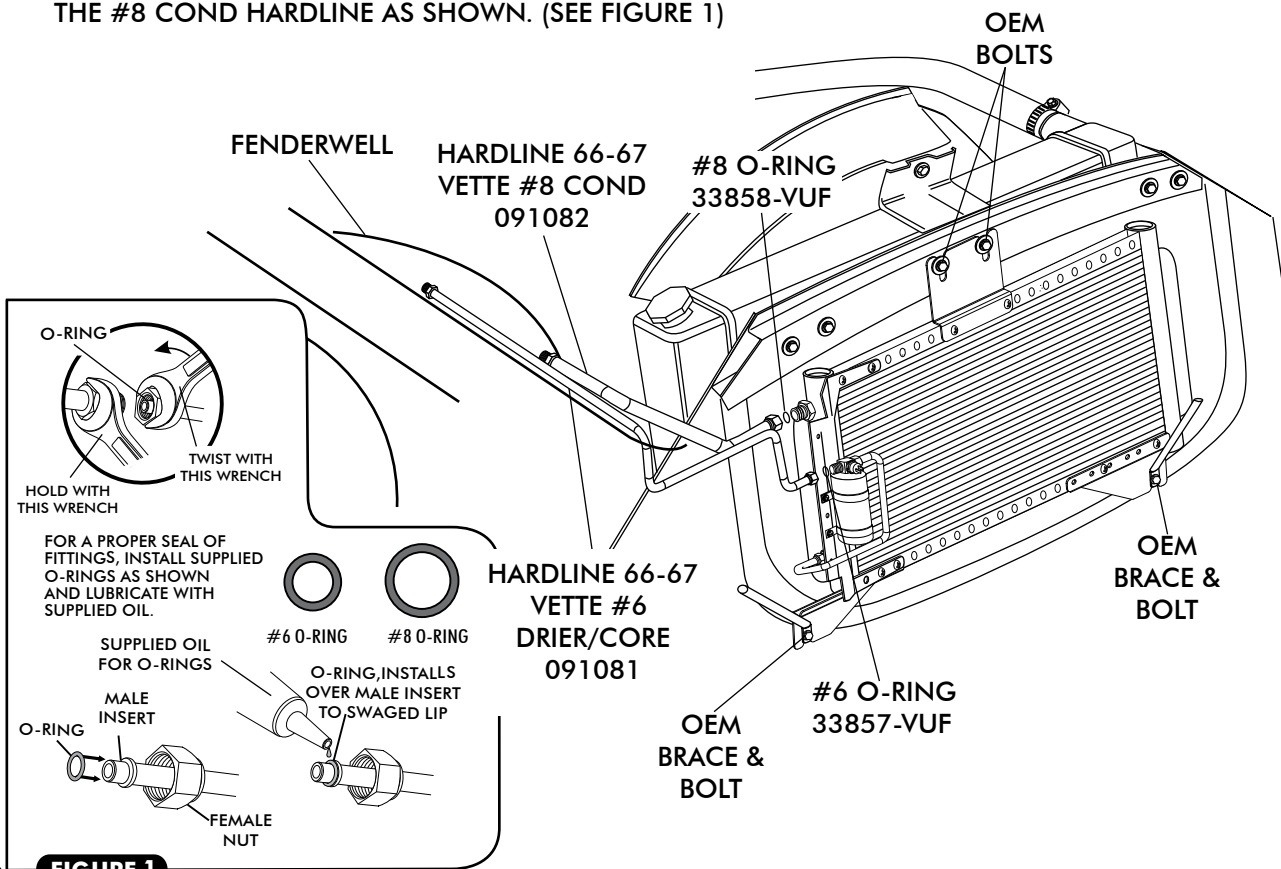
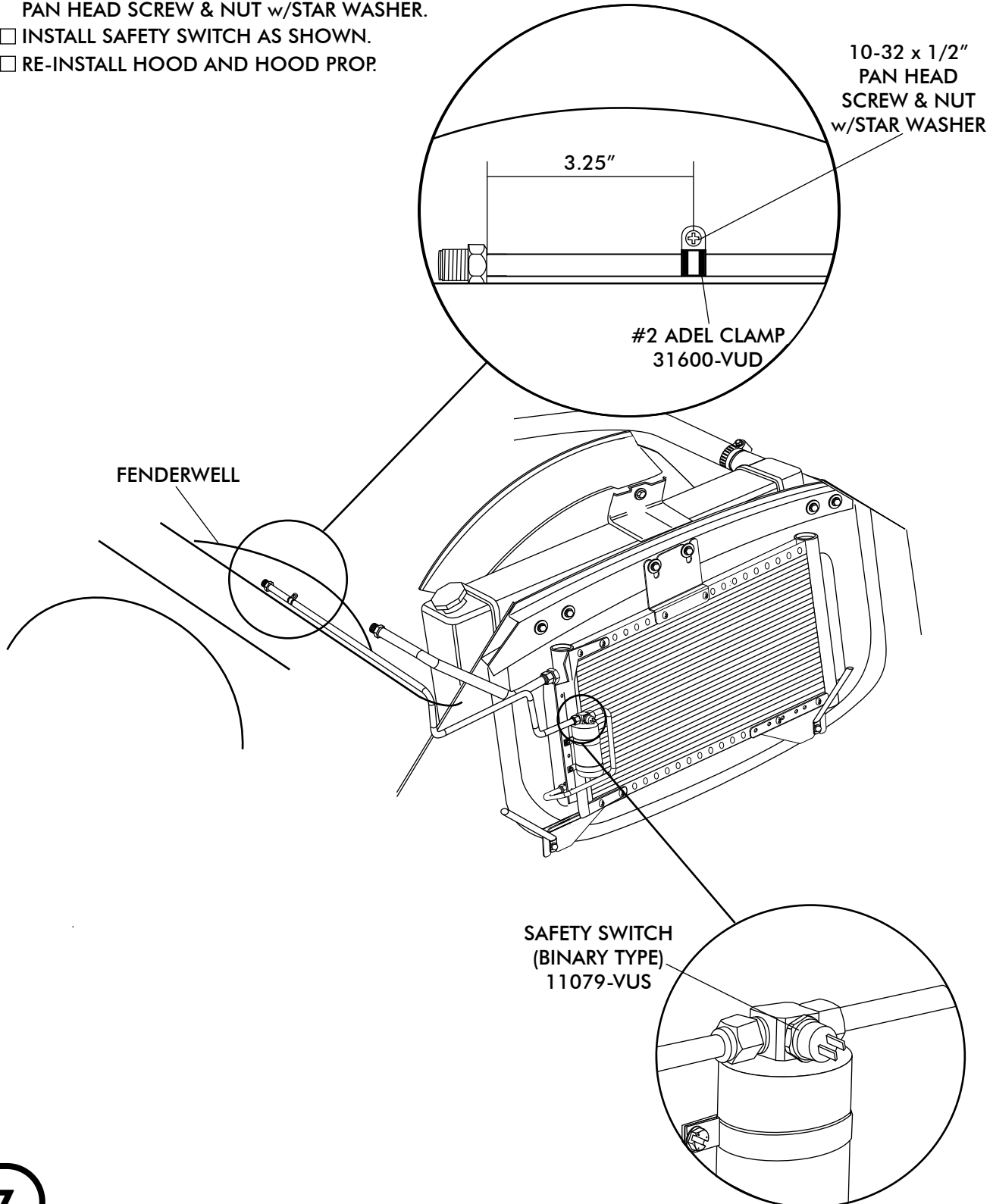

FIGURE 1



HARDLINE CLAMP & SAFETY SWITCH INSTALLATION

- SECURE #6 DRIER/CORE HARDLINE TO INNER FENDER AS SHOWN USING #2 ADEL CLAMP AND 10-32 x 1/2" PAN HEAD SCREW & NUT w/STAR WASHER.
- INSTALL SAFETY SWITCH AS SHOWN.
- RE-INSTALL HOOD AND HOOD PROP.





**CONDENSER KIT
021164**

No.	QTY.	PART No.	DESCRIPTION
1.	1	03767-VUC	14 X 24 PARALLEL FLOW COND.
2.	2	07113-VUB	DRIER CLAMP
3.	1	07321-VUC	DRIER
4.	1	644034	BRKT 66-67 VETTE COND TOP
5.	1	644038	BRKT 63-67 VETTE COND PASS SIDE BTM
6.	1	644039	BRKT 63-67 VETTE COND DR SIDE BTM
7.	1	644051	BRKT 14 3/4" TYPE 2 UNIVERSAL DRIER
8.	1	091081	HARDLINE 66-67 VETTE #6 DRIER/CORE
9.	1	091082	HARDLINE 66-67 VETTE #8 COND
10.	1	35130-VCG	HARDLINE 63-67 VETTE COND/DRIER
11.	8	18260-VUB	10-24 NUT w/STAR WASHER
12.	8	18249-VUB	10-24 x 3/8" PAN HEAD SCREW
13.	3	33857-VUF	#6 O-RING
14.	1	33858-VUF	#8 O-RING
15.	2	18247-VUB	#10 x 1/2" HEX SCREW
16.	1	11079-VUS	MALE BINARY SWITCH
17.	1	23135-VUW	COMPRESSOR LEAD
18.	1	31600-VUD	#2 ADEL CLAMP
19.	1	18250-VUB	10-32 x 1/2" PAN HEAD SCREW
20.	1	18251-VUB	10-32 NUT w/STAR WASHER

CHECKED BY: _____
 PACKED BY: _____
 DATE: _____

