

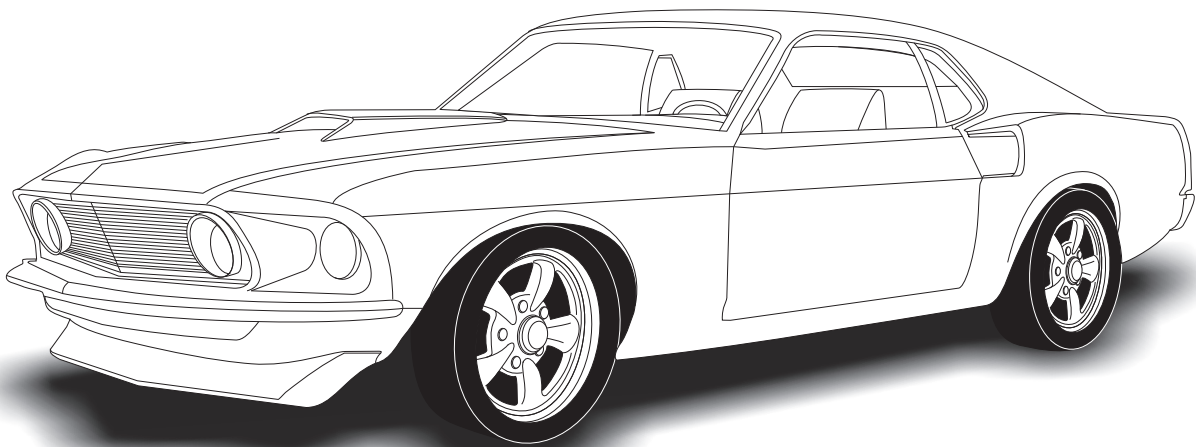

1969-70 MUSTANG

w & w/o AC CONDENSER KIT

017069



18865 GOLL ST. - SAN ANTONIO, TX. - 78266 ph.210-654-7171- fax 210-654-3113



Table of Contents

PAGES

1. COVER
2. TABLE OF CONTENTS
3. PACKING LIST/PARTS DISCLAIMER
4. INFORMATION PAGE
5. CONDENSER BRACKET INSTALLATION
FIGURE 1
6. CONDENSER ASSEMBLY AND FAN SHROUD INSTALLATION
FIGURES 2 & 3
7. PACKING LIST



1969-70 MUSTANG CONDENSER KIT

1969-70 MUSTANG w & w/o AC CONDENSER KIT PACKING LIST

CONDENSER KIT
017069

No.	QTY.	PART No.	DESCRIPTION
1.	1	03765-VUC	SUPER FLOW CONDENSER 14 X 20
2.	1	642070	69-70 MUSTANG DS COND BRKT
3.	1	642069	69-70 MUSTANG PS COND BRKT
4.	8	18260-VUB	10/24 NUT w/STAR WASHER
5.	8	18249-VUB	10-24 X 3/8 PAN HEAD SCREW
6.	4	18290-VUB	1/4-20 X 1 HEX BOLT
7.	4	18125-VUB	1/4 FLAT WASHER
8.	4	18978-VUB	1/4 U-NUT

**** BEFORE BEGINNING INSTALLATION OPEN ALL PACKAGES AND CHECK CONTENTS OF SHIPMENT. PLEASE REPORT ANY SHORTAGES DIRECTLY TO VINTAGE AIR WITHIN 15 DAYS. AFTER 15 DAYS, VINTAGE AIR WILL NOT BE RESPONSIBLE FOR MISSING OR DAMAGED ITEMS.**

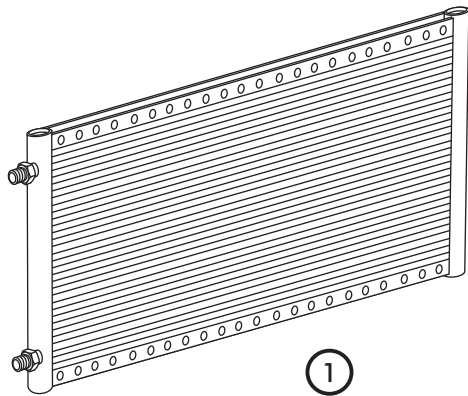

①

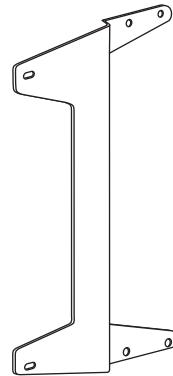

②

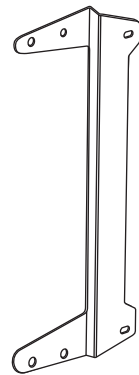

③



④



⑤

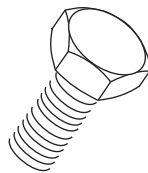

⑥



⑦

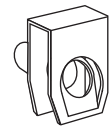

⑧



1969-70 MUSTANG

IMPORTANT NOTICE-PLEASE READ

THIS KIT WAS DEVELOPED BASED ON THE MEASUREMENTS BELOW, WHICH WERE TAKEN FROM A 1969 MUSTANG w/ FACTORY AIR CORE SUPPORT.

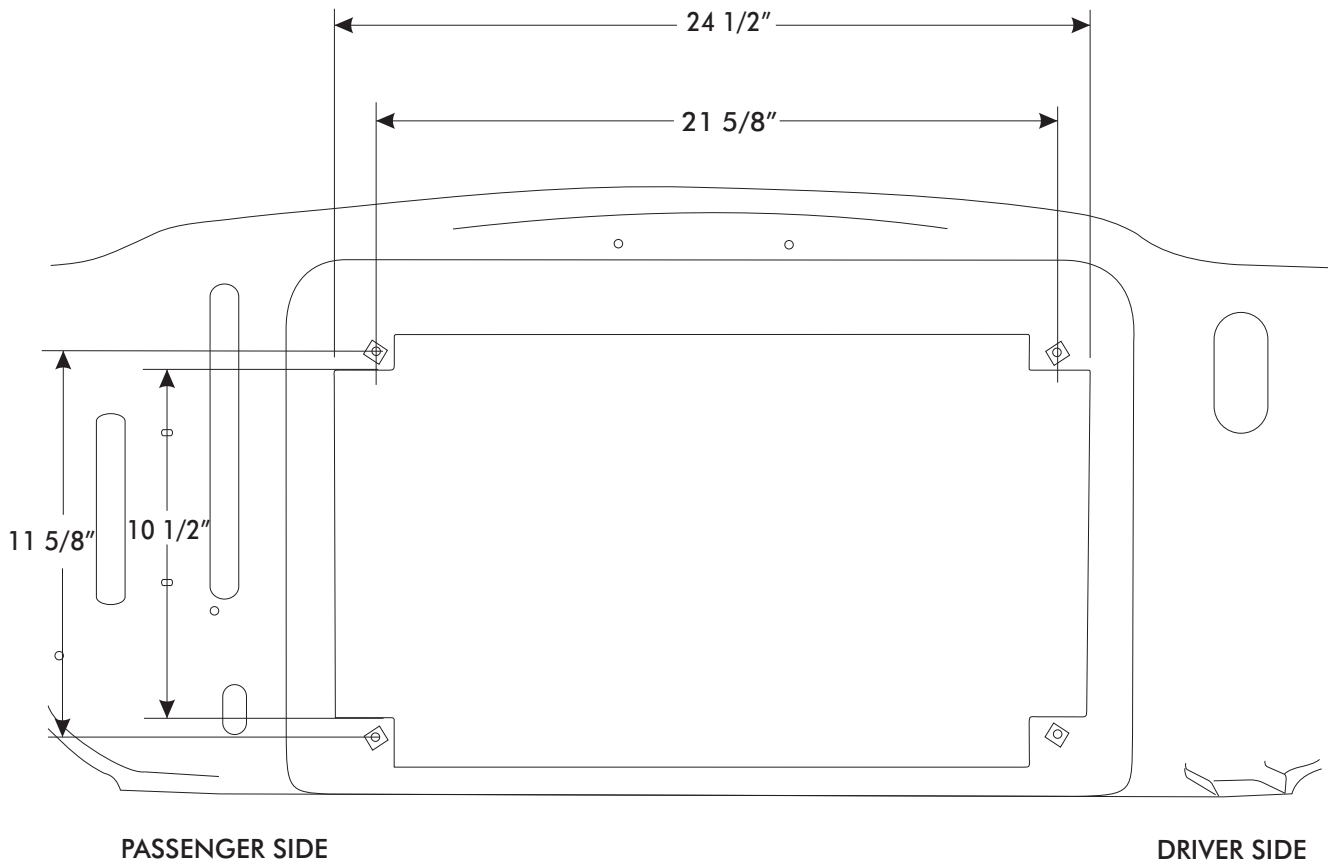



CONDENSER BRACKET INSTALLATION

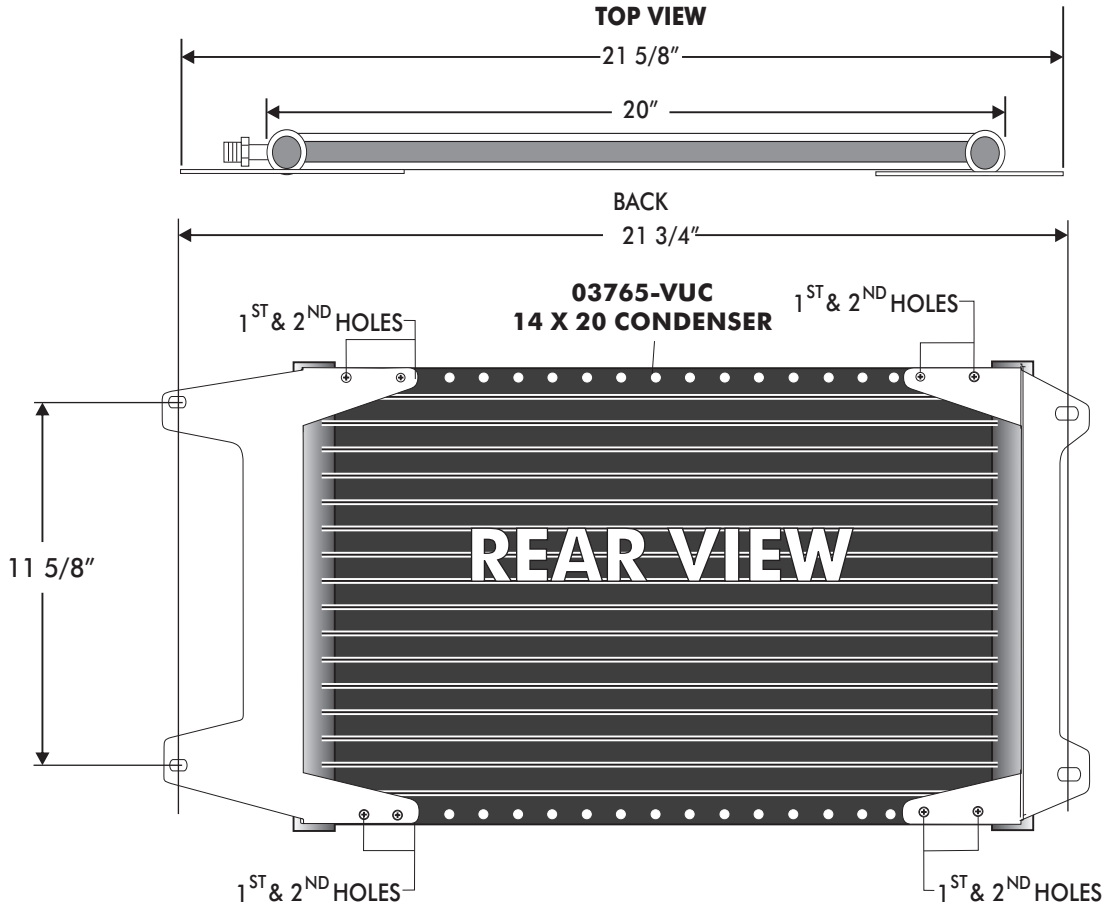

- INSTALL CONDENSER MOUNTING BRACKET ONTO CONDENSER USING (8) 10/24 X 3/8 PAN HEAD SCREWS AND (8) 10/24 NUTS WITH STAR WASHERS. SEE FIGURE 1 BELOW.
- NOTE: BRACKETS MOUNT THROUGH THE FIRST AND SECOND HOLE OF THE CONDENSER.**

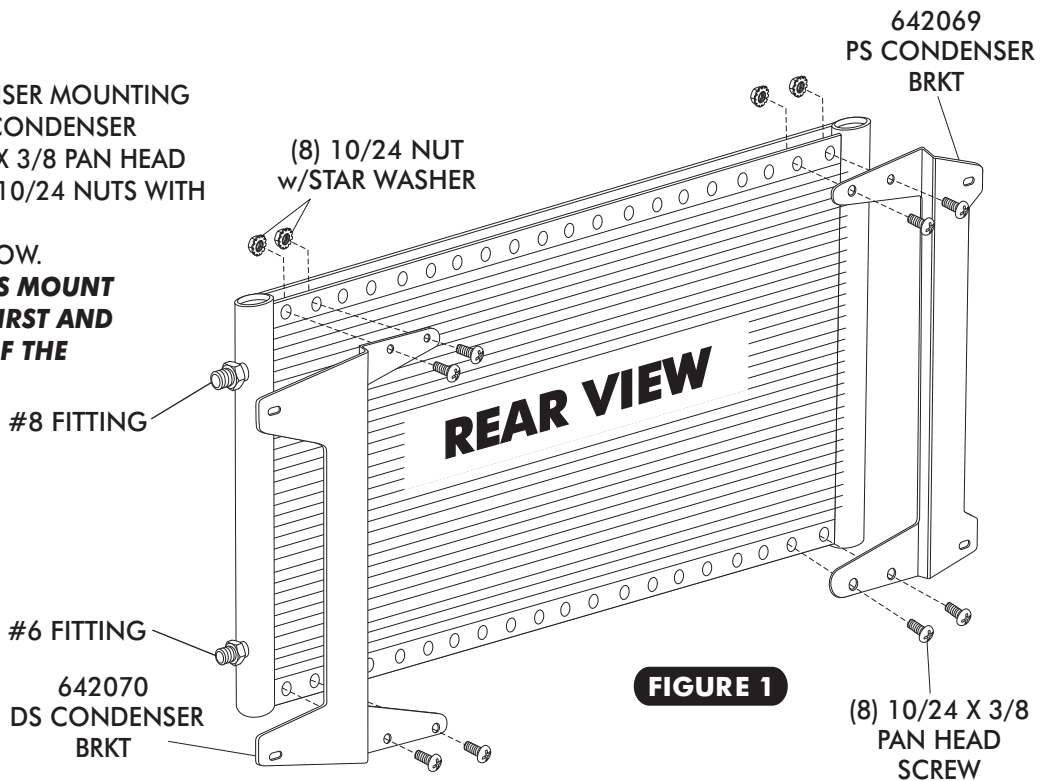

FIGURE 1

CONDENSER ASSEMBLY AND FAN SHROUD INSTALLATION

- INSTALL (4) 1/4 U-NUTS ON CORE SUPPORT AS SHOWN BELOW IN FIGURE 2.
- INSTALL CONDENSER ASSEMBLY BETWEEN THE RADIATOR AND THE CORE SUPPORT SEE FIGURE 2 BELOW.

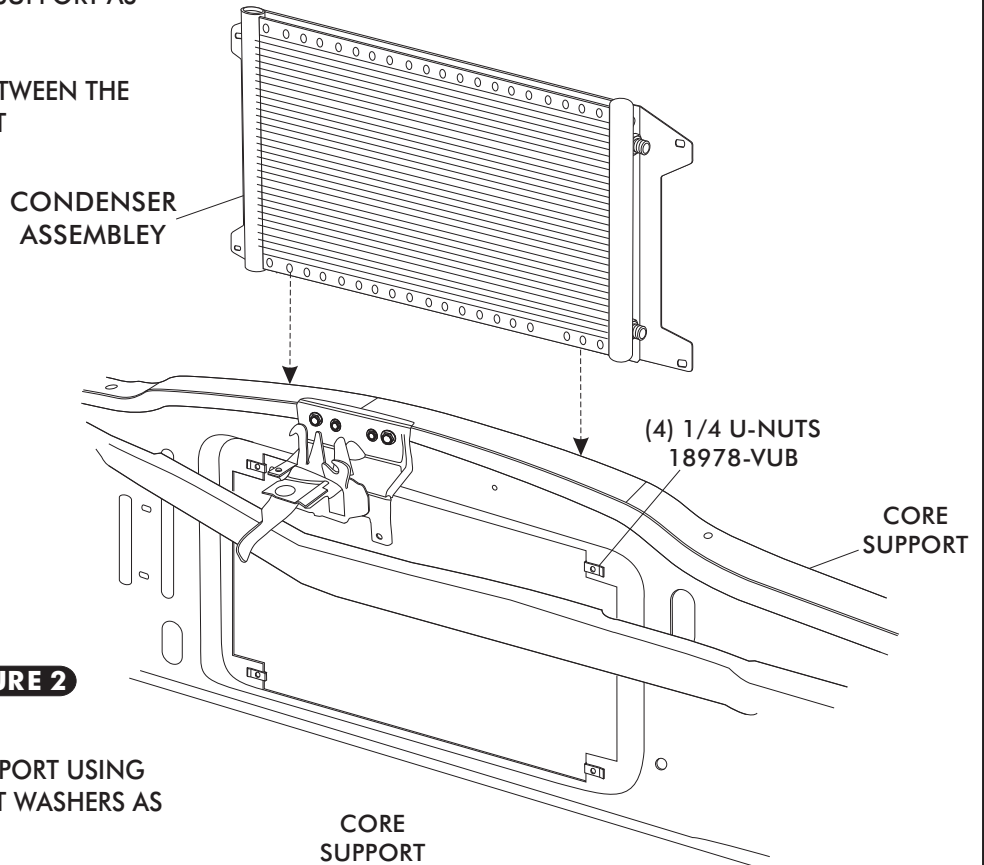

FIGURE 2

- SECURE CONDENSER TO CORE SUPPORT USING (4) 1/4-20 X 1 HEX BOLTS, AND FLAT WASHERS AS SHOWN IN FIGURE 3.
- REINSTALL FAN SHROUD USING OEM HARDWARE AS SHOWN BELOW IN FIGURE 3.

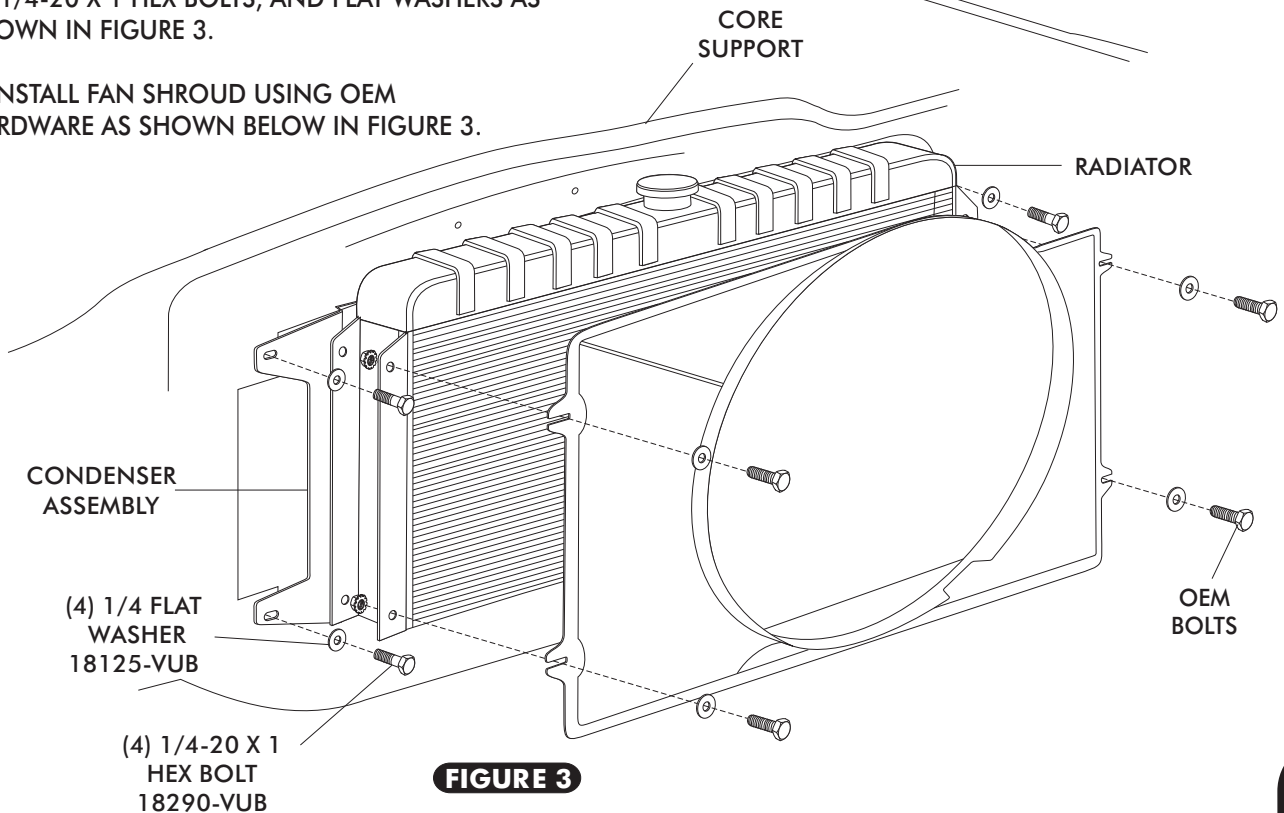

FIGURE 3



1969-70 MUSTANG CONDENSER KIT

1969-70 MUSTANG w & w/o AC CONDENSER KIT PACKING LIST

CONDENSER KIT
017069

No.	QTY.	PART No.	DESCRIPTION	
1.	1	03765-VUC	SUPER FLOW CONDENSER 14 X 20	_____
2.	1	642070	69-70 MUSTANG DS COND BRKT	_____
3.	1	642069	69-70 MUSTANG PS COND BRKT	_____
4.	8	18260-VUB	10/24 NUT w/STAR WASHER	_____
5.	8	18249-VUB	10-24 X 3/8 PAN HEAD SCREW	_____
6.	4	18290-VUB	1/4-20 X 1 HEX BOLT	_____
7.	4	18125-VUB	1/4 FLAT WASHER	_____
8.	4	18978-VUB	1/4 U-NUT	_____

CHECKED BY: _____
 PACKED BY: _____
 DATE: _____

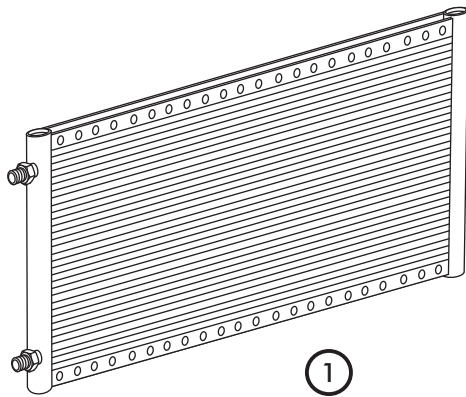

①

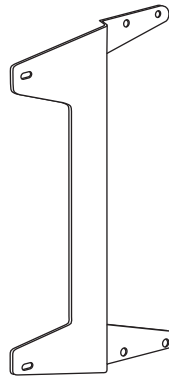

②

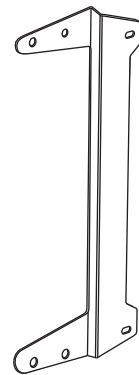

③



④



⑤

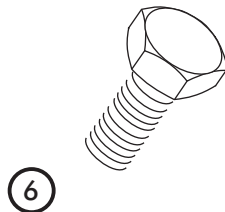

⑥

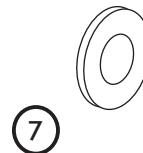

⑦

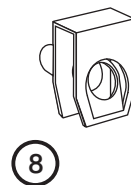

⑧

**NOTE: IMAGES MAY NOT DEPICT ACTUAL PARTS AND QUANTITIES.
 REFER TO PACKING LIST FOR ACTUAL PARTS AND QUANTITIES.**