



an ISO 9001:2008 Registered Company

1967-72 CHEV PICK-UP

CONDENSER KIT

026067

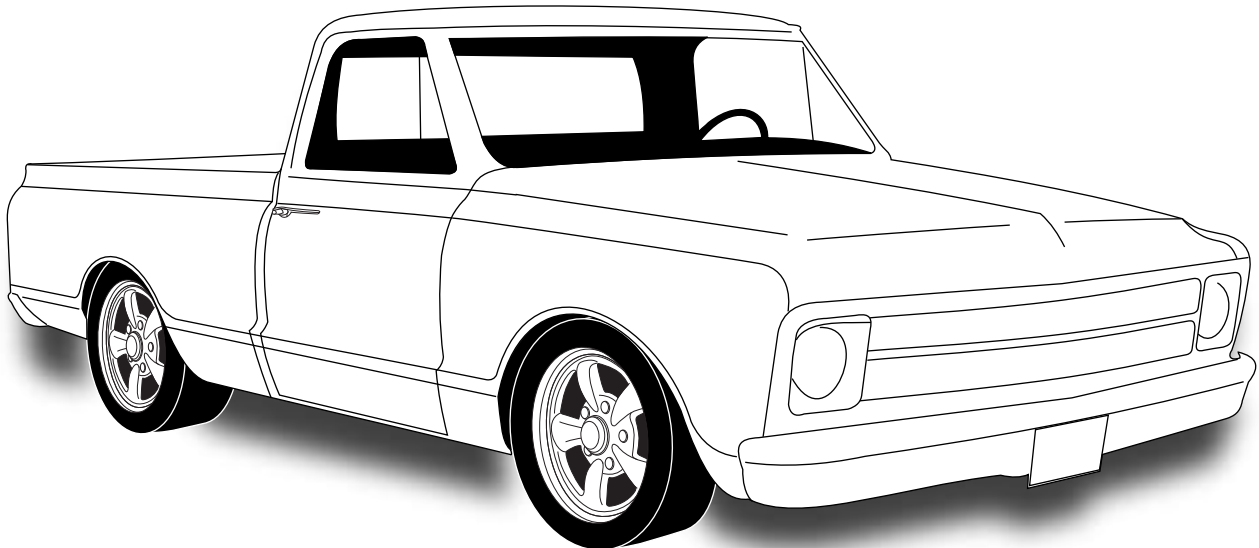

18865 GOLL ST. - SAN ANTONIO, TX. - 78266 ph.210-654-7171 - fax 210-654-3113



TABLE OF CONTENTS

PAGES

1. COVER
2. TABLE OF CONTENTS
3. PACKING LIST/PARTS DISCLAIMER
4. HOOD LATCH ASM. & MOUNTING BRACKET INSTALLATION
5. MOUNTING BRACKET INSTALLATION & CONDENSER INSTALLATION
6. CONDENSER INSTALLATION CONT.
7. PACKING LIST



1967-72 CHEV PICK-UP CONDENSER

**CONDENSER KIT
026067**

No.	QTY.	PART No.	DESCRIPTION
1.	1	03767-VUC	14" X 24" PARALLEL FLOW COND.
2.	2	18101-VUB	10-32 WELL NUT
3.	6	18249-VUB	10-24 X 3/8" PAN HEAD SCREW
4.	2	18253-VUB	10-32 X 1" PAN HEAD SCREW
5.	6	18260-VUB	10-24 NUT W/STAR WASHER
6.	1	644078	BRKT 67-72 CHEV P-UP TOP COND
7.	1	644079	BRKT 67-72 CHEV P-UP BOTTOM COND

****BEFORE BEGINNING INSTALLATION OPEN ALL PACKAGES AND CHECK CONTENTS OF SHIPMENT PLEASE REPORT ANY SHORTAGES DIRECTLY TO VINTAGE AIR WITHIN 15 DAYS. AFTER 15 DAYS, VINTAGE AIR WILL NOT BE RESPONSIBLE FOR MISSING OR DAMAGED ITEMS.**

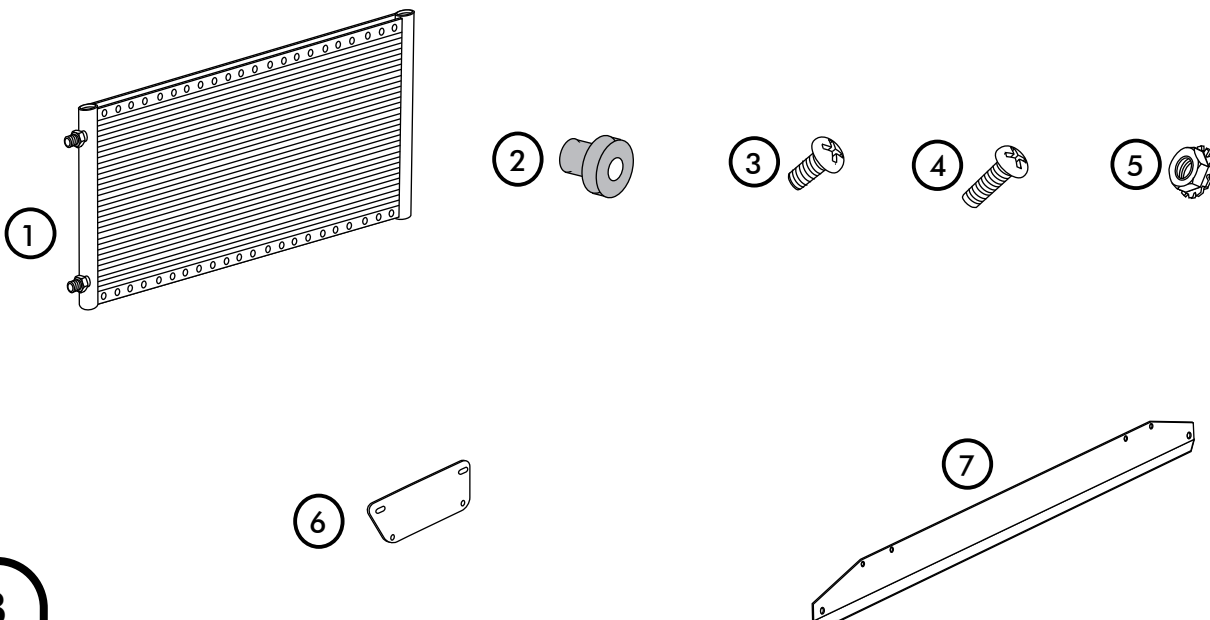



HOOD LATCH ASSEMBLY

- REMOVE OEM HOOD LATCH ASSEMBLY AS SHOWN.

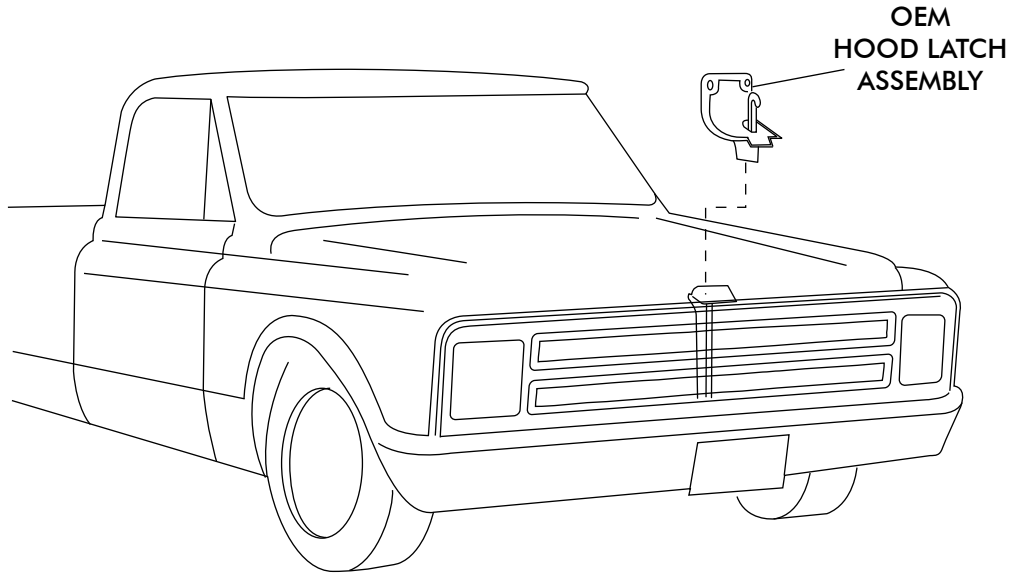

MOUNTING BRACKET INSTALLATION

- INSTALL TOP MOUNTING BRACKET ON TO CONDENSER USING 10-24 X 3/8" PAN HEAD SCREWS AND 10-24 NUTS WITH STAR WASHERS. **NOTE BRACKET MOUNTS THROUGH THE 8TH & 13TH HOLE FROM THE LEFT SIDE OF THE CONDENSER.**

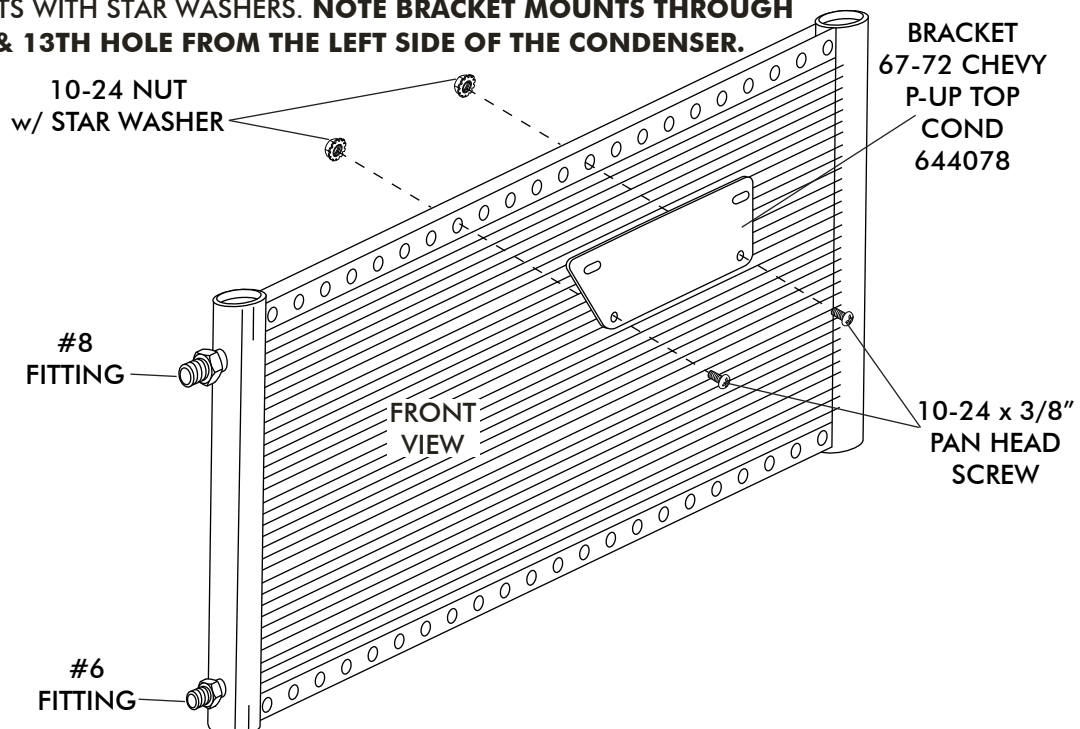



MOUNTING BRACKET INSTALLATION CONT.

- INSTALL BOTTOM MOUNTING BRACKET ON TO CONDENSER USING 10-24 X 3/8" PAN HEAD SCREWS AND 10-24 NUTS WITH STAR WASHERS. **NOTE: BRACKET MOUNTS THROUGH 1ST AND 3RD HOLES FROM BOTH SIDES OF THE CONDENSER.**

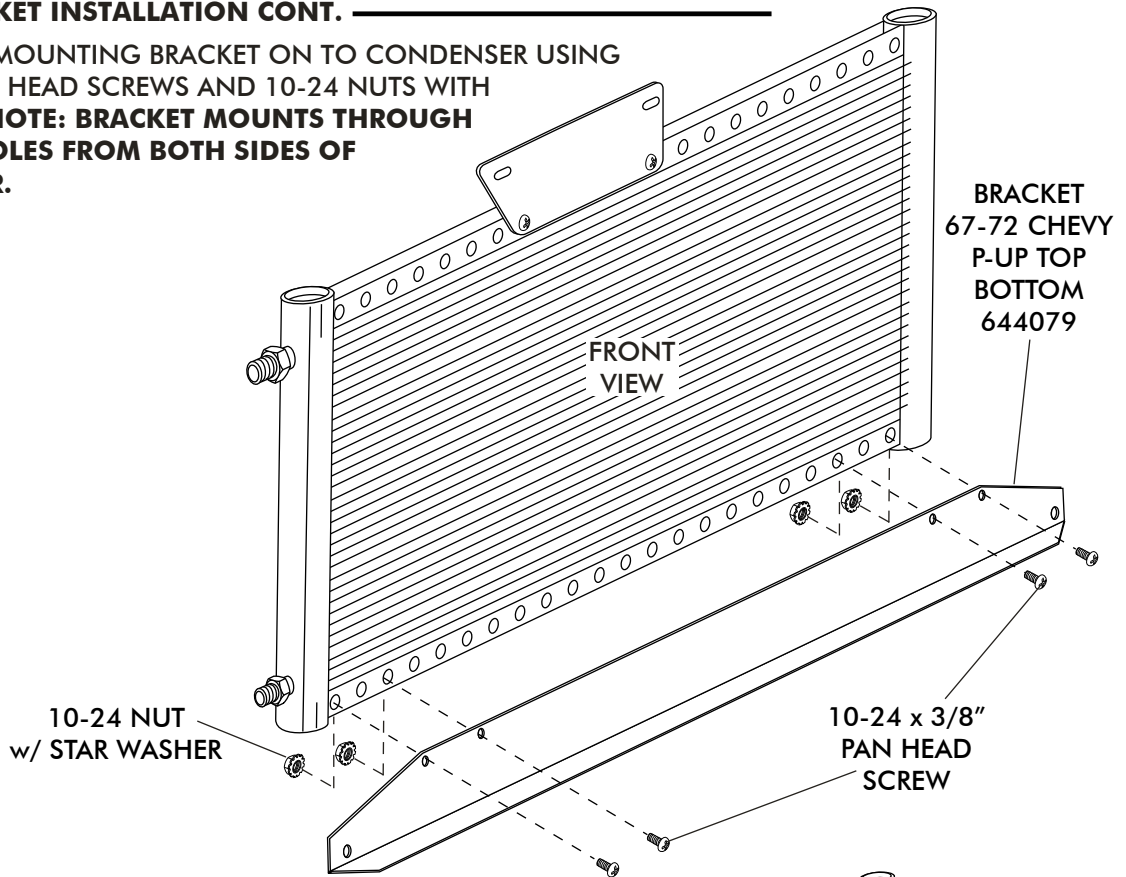

CONDENSER INSTALLATION

NOTE: NON FACTORY AC TRUCKS USE OEM DIMPLE AND DRILL 3/8" HOLE OR USE LOWER CONDENSER BRACKET AS TEMPLATE.

- INSTALL 10-32 WELL NUTS INTO OEM HOLES.
- INSTALL CONDENSER AS SHOWN BELOW, LOWER CONDENSER BETWEEN FRONT SIDE OF CORE SUPPORT AND GRILLE.

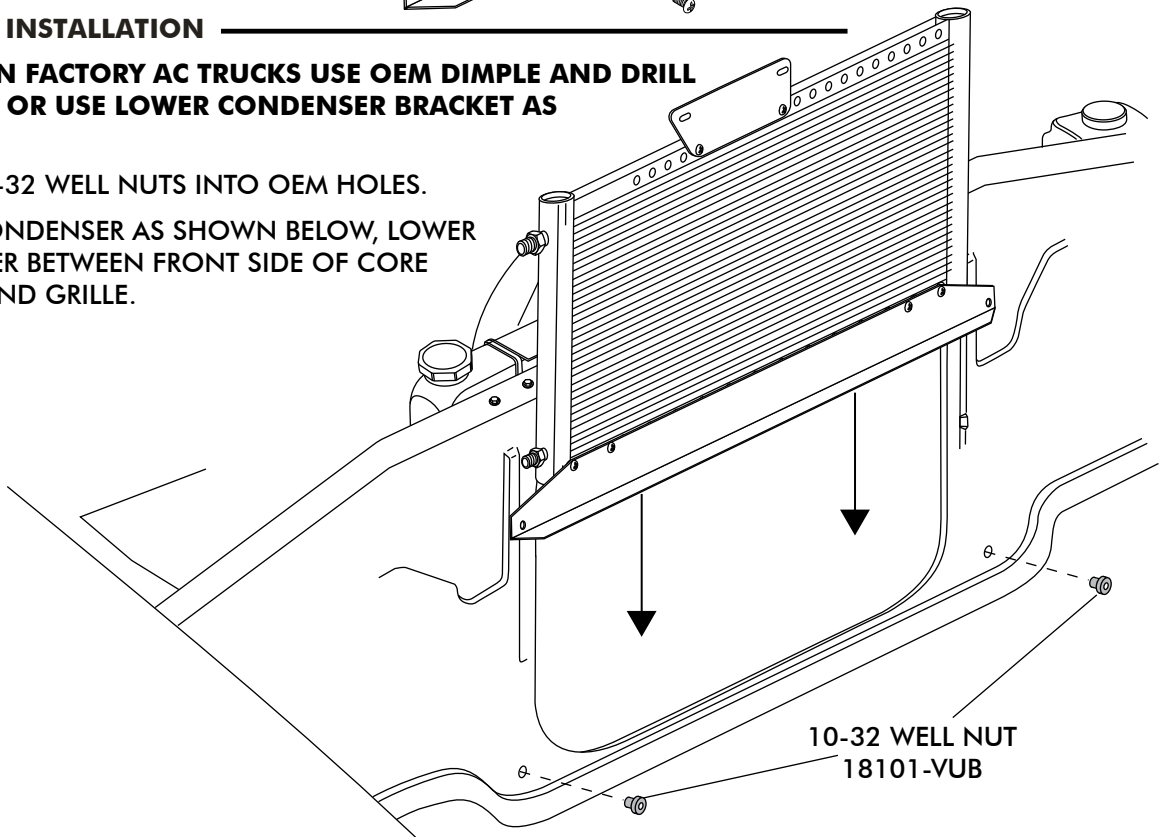



CONDENSER INSTALLATION CONT.

- USING OEM BOLTS RE-INSTALL HOOD LATCH ASSEMBLY. INSTALL OEM BOLTS THROUGH HOOD LATCH ASSEMBLY, CONDENSER BRACKET AND CORE SUPPORT.
- USING 10-32 X 1" PAN HEAD SCREWS, SECURE BOTTOM CONDENSER BRACKET TO CORE SUPPORT.

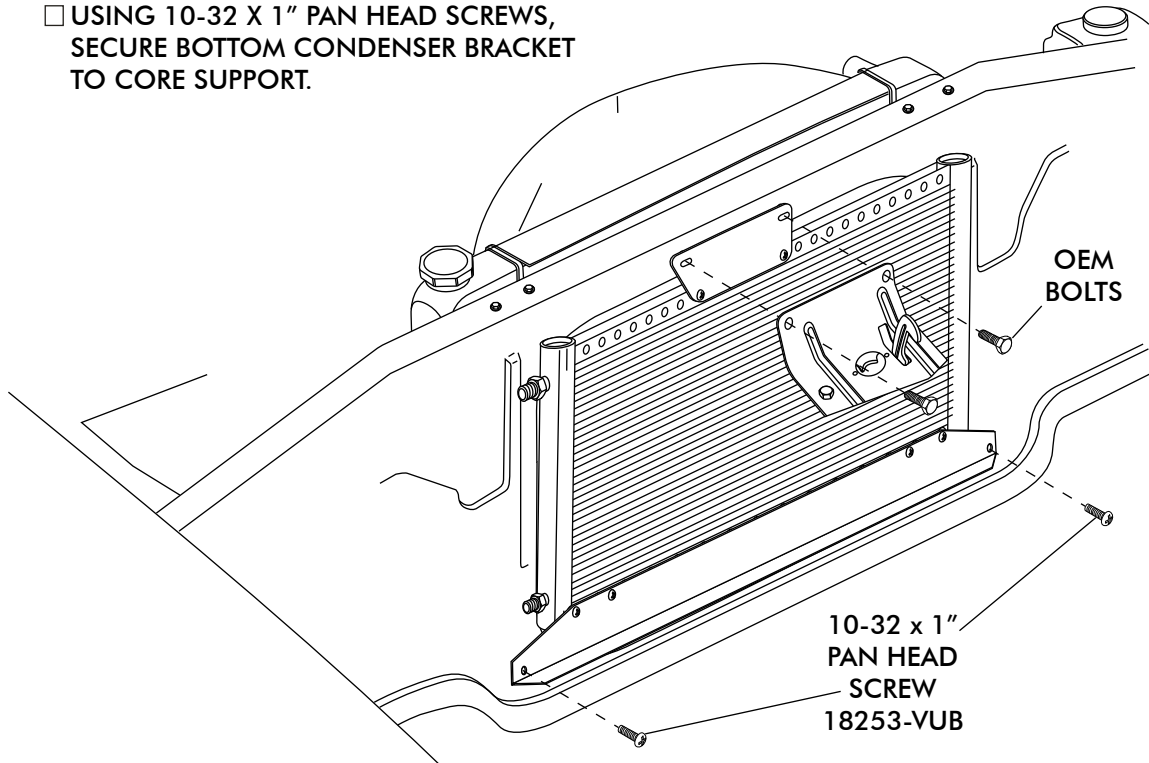



1967-72 CHEV PICK-UP CONDENSER

**CONDENSER KIT
026067**

No.	QTY.	PART No.	DESCRIPTION	
1.	1	03767-VUC	14" X 24" PARALLEL FLOW COND.	_____
2.	2	18101-VUB	10-32 WELL NUT	_____
3.	6	18249-VUB	10-24 X 3/8" PAN HEAD SCREW	_____
4.	2	18253-VUB	10-32 X 1" PAN HEAD SCREW	_____
5.	6	18260-VUB	10-24 NUT W/STAR WASHER	_____
6.	1	644078	BRKT 67-72 CHEV P-UP TOP COND	_____
7.	1	644079	BRKT 67-72 CHEV P-UP BOTTOM COND	_____

CHECKED BY: _____
 PACKED BY: _____
 DATE: _____

