



an ISO 9001:2008 Registered Company

1968 CORVETTE

CONDENSER KIT w/DRIER

021068

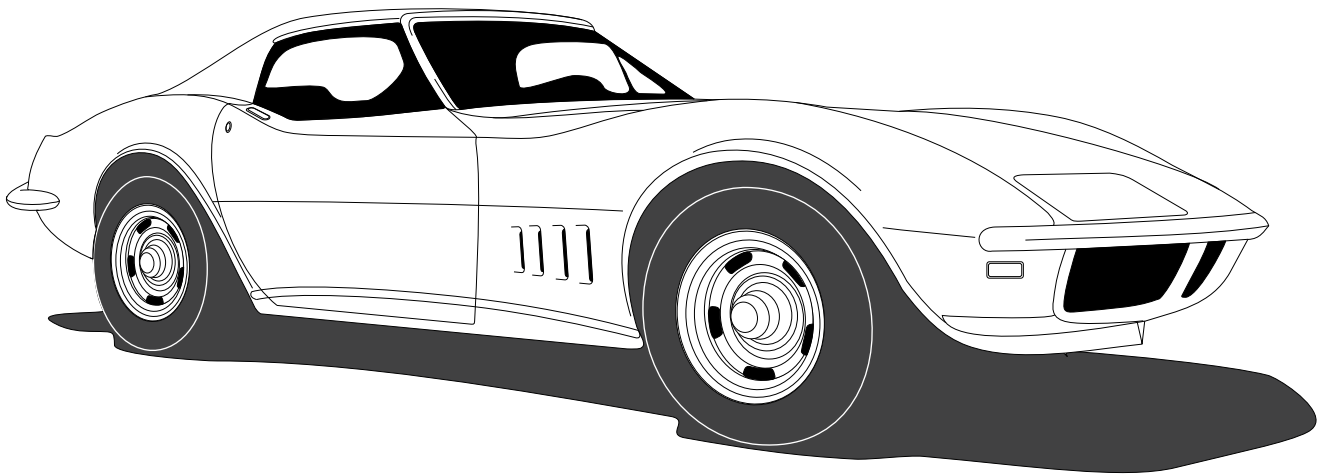

18865 GOLL ST. - SAN ANTONIO, TX. - 78266 ph.210-654-7171 - fax 210-654-3113



Table of Contents

PAGES

1. COVER
2. TABLE OF CONTENTS
3. PACKING LIST/PARTS DISCLAIMER
4. CONDENSER BRACKET INSTALLATION
FIGURE 1
5. CONDENSER INSTALLATION
FIGURE 2
6. CORE SUPPORT MODIFICATION
FIGURES 3 & 4
7. CORE SUPPORT MODIFICATION CONT.
FIGURES 5 & 6
8. HARDLINE INSTALLATION
FIGURES 7, 7a & 7b
9. DRIER INSTALLATION
FIGURES 8 & 9
10. HARDLINE INSTALLATION
FIGURES 10 & 11
11. CORE SUPPORT TEMPLATE
12. CONDENSER KIT PACKING LIST



CONDENSER KIT
021068

CONDENSER KIT PACKING LIST

No.	QTY.	PART No.	DESCRIPTION
1.	1	03767-VUC	SUPER FLOW CONDENSER 14 x 24
2.	1	07321-VUC	DRIER
3.	1	65980-VCB	DRIER CLAMP
4.	1	644077	68 VETTE DS COND BRKT
5.	1	644076	68 VETTE PS COND BRKT
6.	1	091072	HARDLINE 68 VETTE #6 COND/DRIER
7.	1	091069-CCL	68-72 VETTE #6 DRIER/CORE HARDLINE
8.	1	091073	HARDLINE 68 VETTE #8 COND
9.	1	620069-CCE	68-72 HARDLINE COVER
10.	8	18260-VUB	10-24 NUT w/ STAR WASHER
11.	8	18249-VUB	10-24 x 3/8" PAN HEAD SCREW
12.	3	33857-VUF	#6 O-RING
13.	1	33858-VUF	#8 O-RING
14.	4	18247-VUB	#10 x 1/2" HEX SCREW
15.	2	33143-VUI	CATERPILLAR GROMMET
16.	1	18151-VUB	5/16" NYLON NUT
17.	1	11079-VUS	MALE BINARY SWITCH
18.	1	23135-VUW	COMPRESSOR LEAD
19.	1	183009-DSR	5/16-18 x 1 1/4" HEX BOLT

**** BEFORE BEGINNING INSTALLATION OPEN ALL PACKAGES AND CHECK CONTENTS OF SHIPMENT. PLEASE REPORT ANY SHORTAGES DIRECTLY TO VINTAGE AIR WITHIN 15 DAYS. AFTER 15 DAYS, VINTAGE AIR WILL NOT BE RESPONSIBLE FOR MISSING OR DAMAGED ITEMS.**

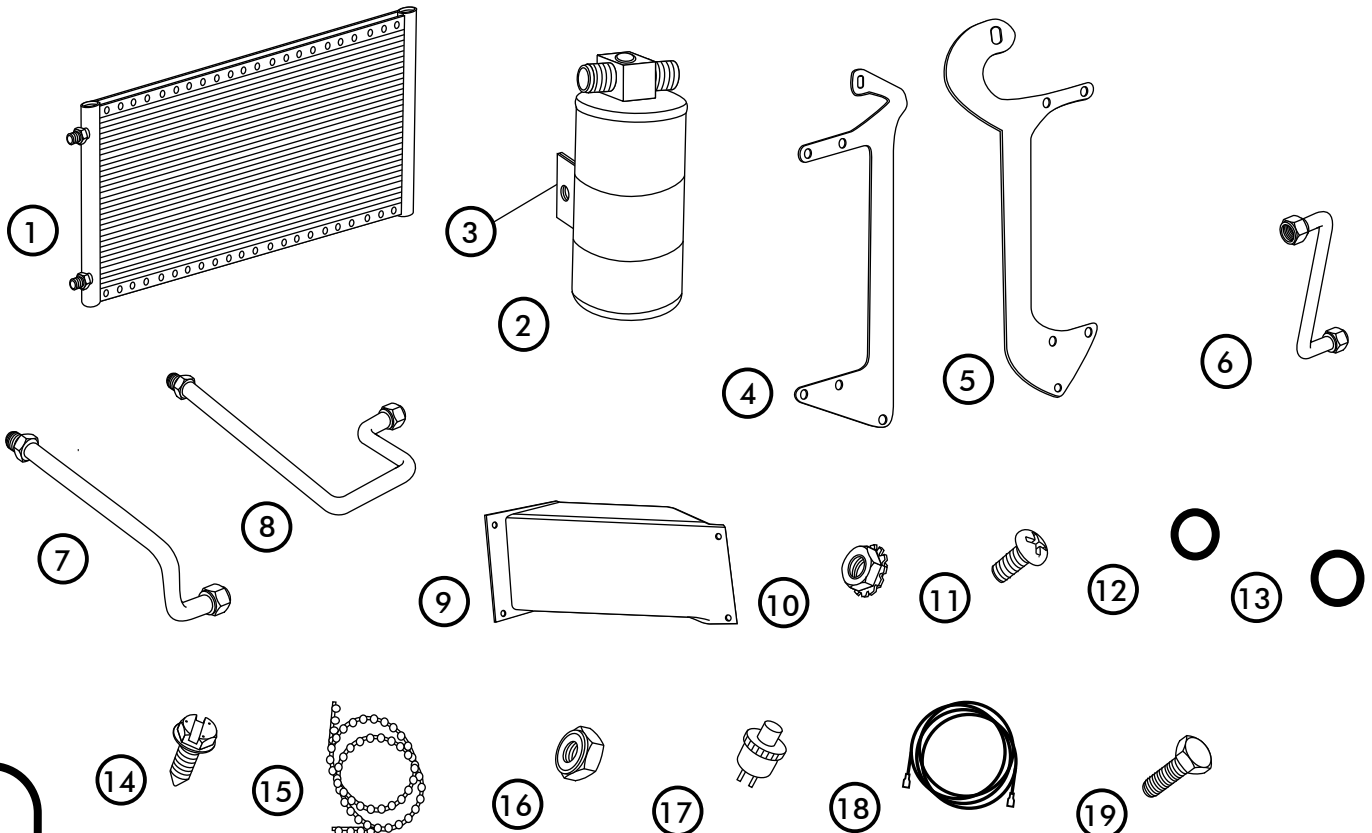



MOUNTING BRACKET INSTALLATION

- INSTALL CONDENSER MOUNTING BRACKET ON TO CONDENSER USING (8) 10-24 x 3/8 PAN HEAD SCREWS AND (8) 10-24 NUTS WITH STAR WASHERS. SEE FIGURE 1 BELOW.

NOTE: BRACKETS MOUNT THROUGH THE FIRST AND THIRD HOLE IN THE CONDENSER.

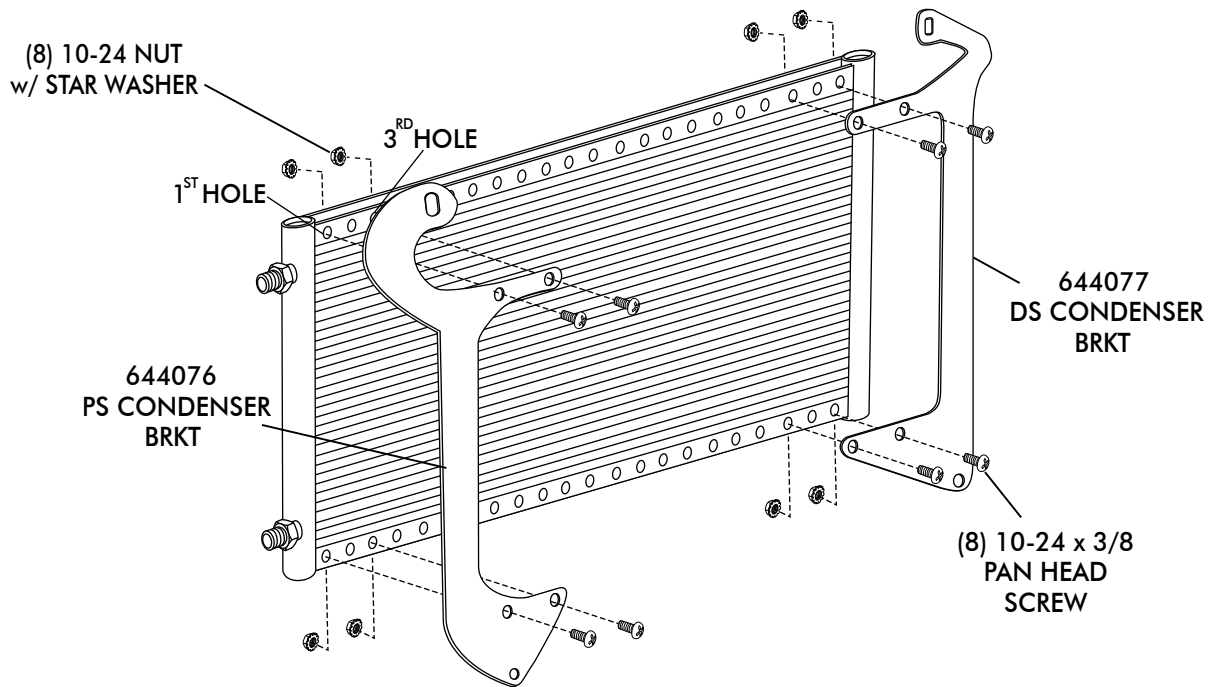

FIGURE 1



ENGINE COMPARTMENT

CONDENSER INSTALLATION

- REMOVE OEM CONDENSER AND LINES IF EQUIP WITH FACTORY AIR. (RETAIN MOUNTING HARDWARE)
- INSTALL CONDENSER ASSEMBLY BY PLACING THE CONDENSER ON THE FRONT SIDE OF THE CORE SUPPORT AND ALIGN WITH OEM MOUNTING HOLES AS SHOWN IN FIGURE 2.

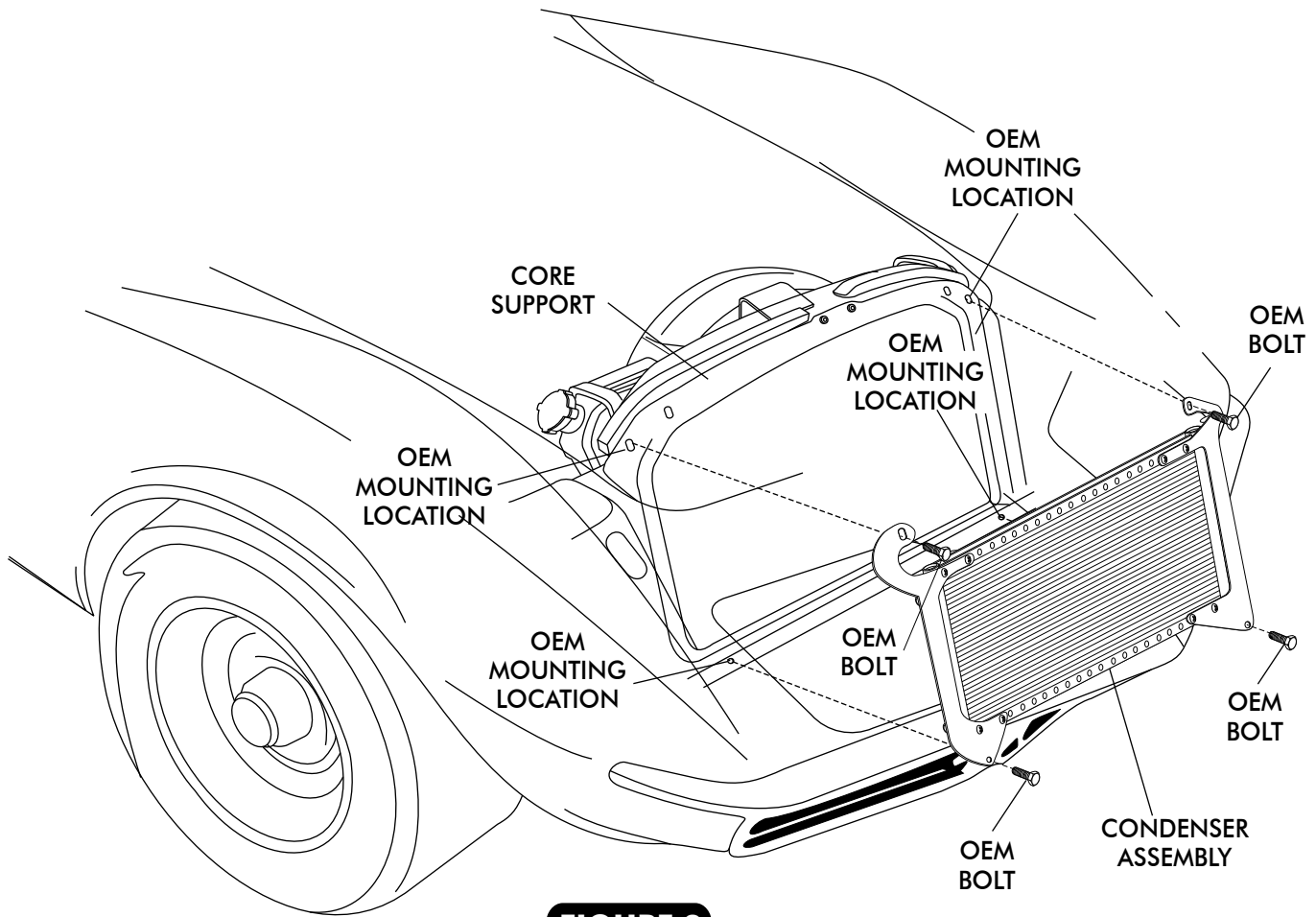

FIGURE 2



CORE SUPPORT MODIFICATION (NON-AIR CARS ONLY)

CUT OUT FRONT CORE SUPPORT TEMPLATE LOCATED ON PAGE 11.

POSITION THE TEMPLATE AS SHOWN (AS NOTED ON TEMPLATE). PLACE THE TOP EDGE ALONG THE HOOD LATCH AS SHOWN AND FOLD THE TEMPLATE OVER ALIGNING THE EDGE OF THE TEMPLATE WITH THE EDGE OF THE CORE SUPPORT AS SHOWN IN FIGURE 3.

ONCE TEMPLATE IS IN PLACE AND SECURE, USE A CENTER-PUNCH AND MARK THE CENTER OF THE TWO CIRCLES ON THE TEMPLATE.

REMOVE THE TEMPLATE AND USE A 1/8" DRILL BIT AND DRILL A PILOT HOLE THROUGH CORE SUPPORT.

FROM UNDER THE FENDERWELL USE A 1.250" HOLE SAW AND ALIGN THE DRILL BIT WITH THE PILOT HOLES AND CUT OUT THE TWO HOLES AS SHOWN IN FIGURE 4 BELOW.

ONCE THE HOLES ARE MADE USE A STRAIGHT EDGE AND MARK A STRAIGHT LINE FROM THE EDGE OF ONE HOLE TO THE OTHER AS SHOWN IN FIGURE 4.

CUT ALONG EDGES AS SHOWN AND REMOVE THE CENTER PORTION BETWEEN THE TWO HOLES. SEE FIGURE 4.

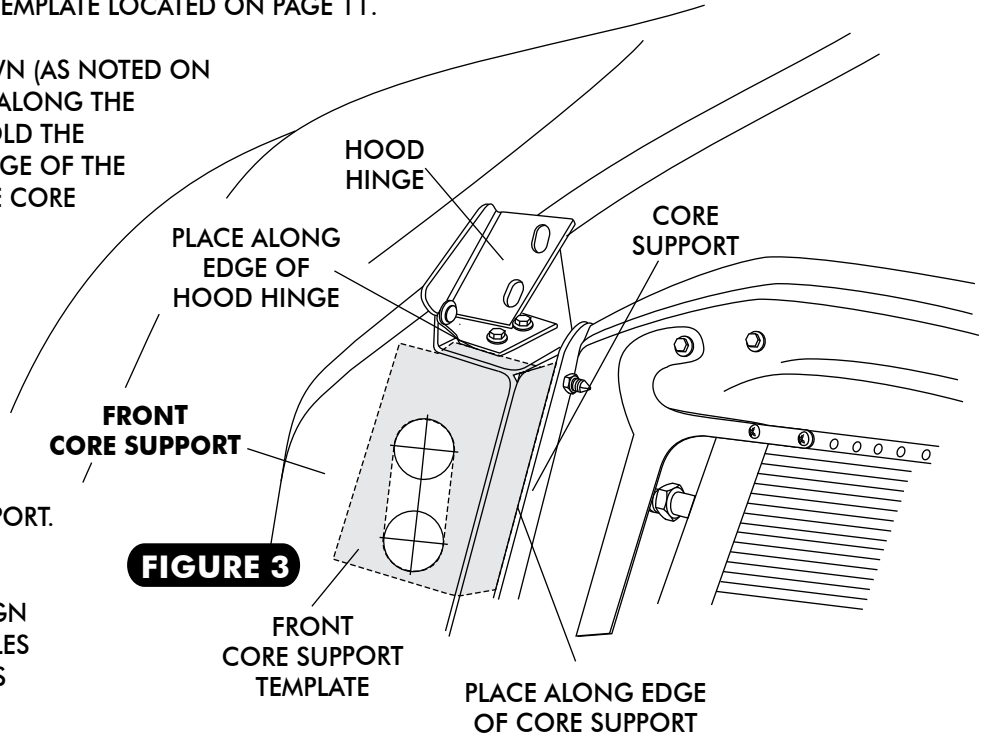

FIGURE 3

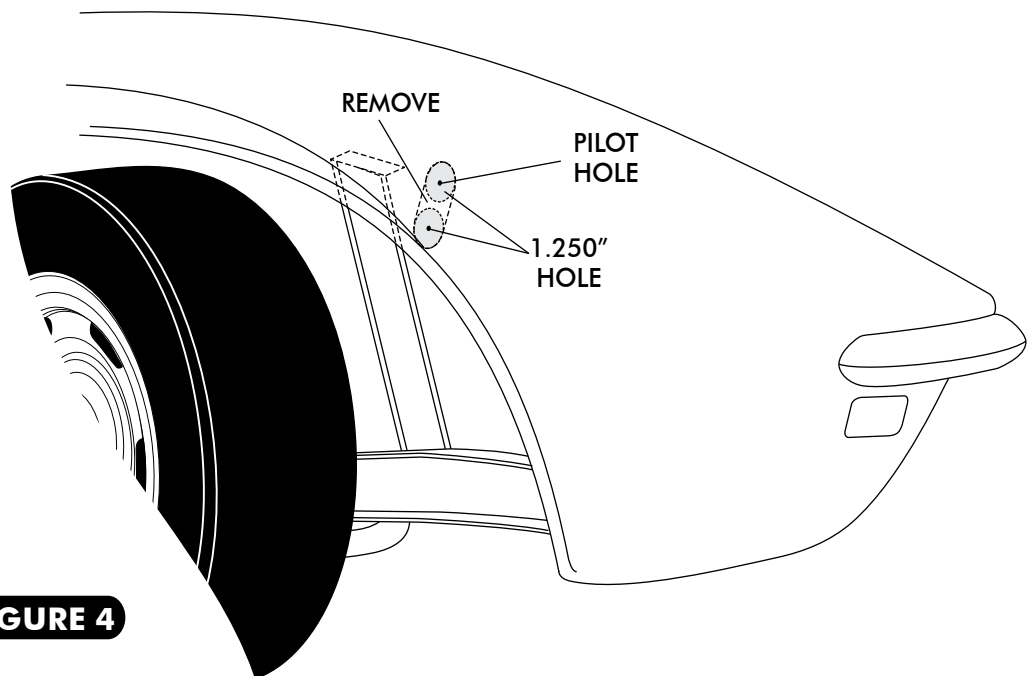

FIGURE 4



CORE SUPPORT MODIFICATION (NON-AIR CARS ONLY)

- CUT OUT THE REAR CORE SUPPORT TEMPLATE LOCATED ON PAGE 11.
- POSITION THE TEMPLATE AS SHOWN (AS NOTED ON TEMPLATE). PLACE THE TOP EDGE ALONG THE TOP EDGE OF THE INNER FENDERWELL AS SHOWN AND FOLD THE TEMPLATE AROUND THE INNER FENDERWELL ALIGNING THE EDGE OF THE TEMPLATE WITH THE EDGE OF THE CORE SUPPORT AS SHOWN IN FIGURE 5.

- ONCE TEMPLATE IS IN PLACE AND SECURE, USE A CENTER-PUNCH AND MARK THE CENTER OF THE TWO CIRCLES ON THE TEMPLATE.

- REMOVE THE TEMPLATE AND USE A 1/8" DRILL BIT AND DRILL A PILOT HOLE THROUGH FENDERWELL.

- FROM UNDER THE FENDERWELL USE A 1.250" HOLE SAW AND ALIGN THE DRILL BIT WITH THE PILOT HOLES AND CUT OUT THE TWO HOLES AS SHOWN IN FIGURE 6 BELOW.

- ONCE THE HOLES ARE MADE USE A STRAIGHT EDGE AND MARK A STRAIGHT LINE FROM THE EDGE OF ONE HOLE TO THE OTHER AS SHOWN IN FIGURE 6.

- CUT ALONG EDGES AS SHOWN AND REMOVE THE CENTER PORTION BETWEEN THE TWO HOLES. SEE FIGURE 6.

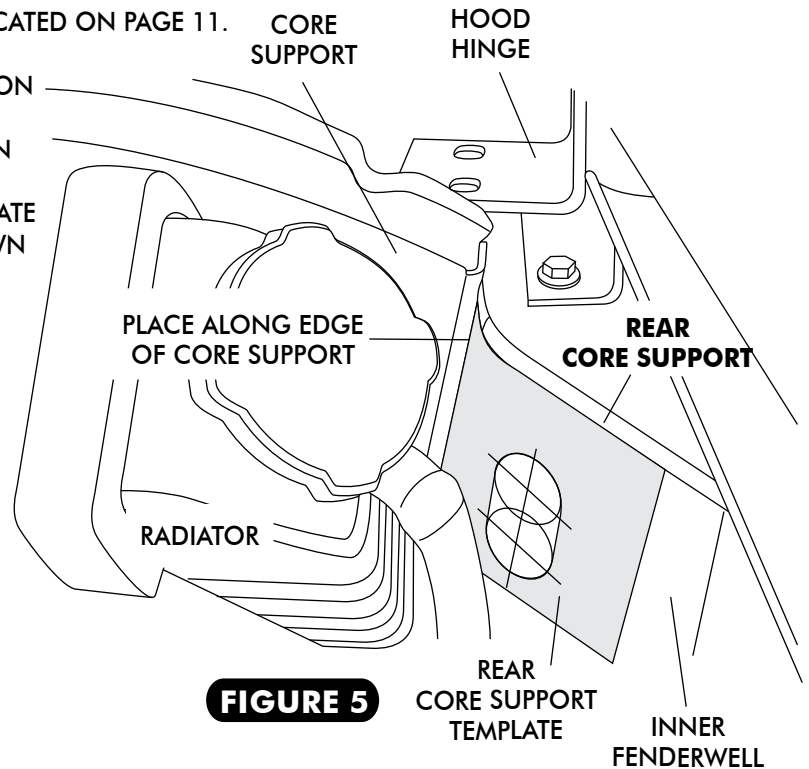

FIGURE 5

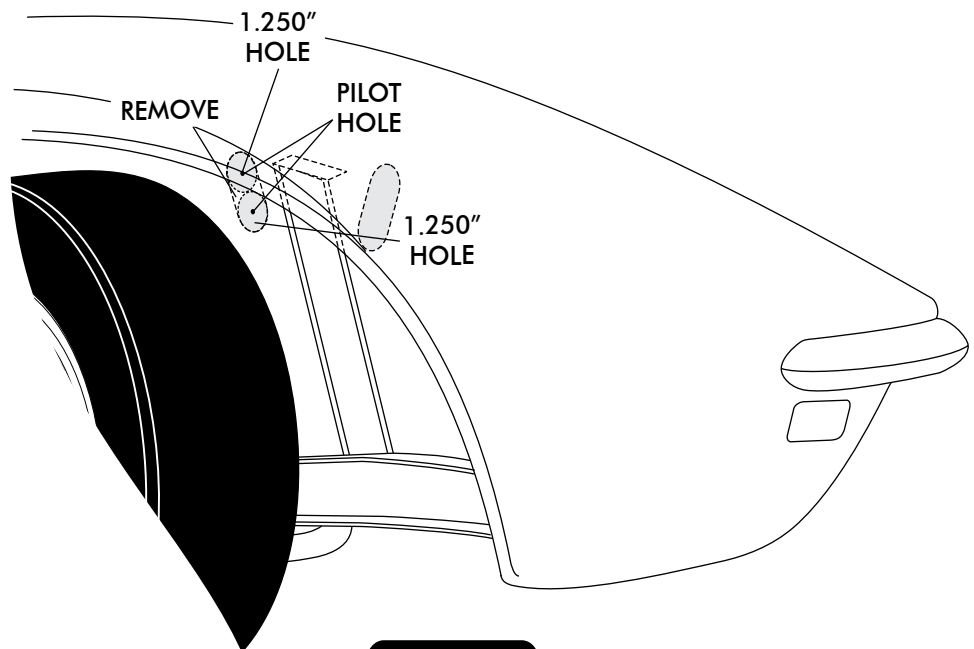

FIGURE 6



HARDLINES AND DRIER INSTALLATION

- INSTALL CATERPILLAR GROMMET AROUND THE FRONT AND REAR HOLES IN THE INNER FENDERWELL AS SHOWN IN FIGURE 7 AND 7b.
- LUBRICATE A #6 O-RING (SEE FIGURE 7a BELOW) AND INSTALL THE #6 CONDENSER TO DRIER HARDLINE AS SHOWN IN FIGURE 7 BELOW.
NOTE: ONLY HAND TIGHTEN THE #6 HARDLINE.

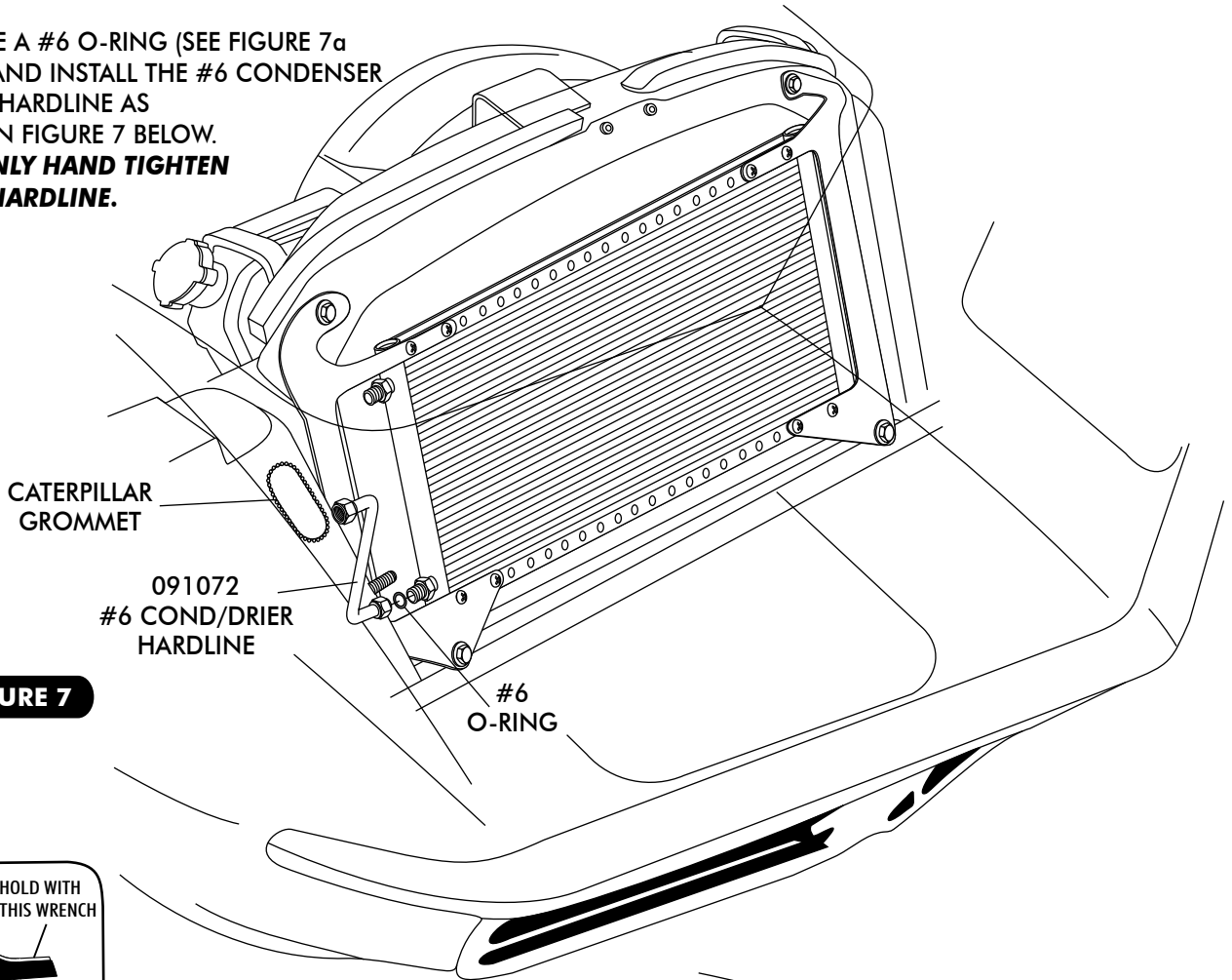

FIGURE 7

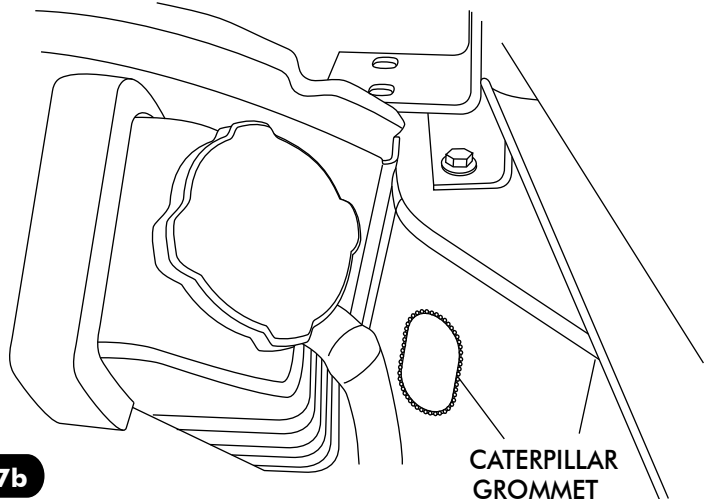
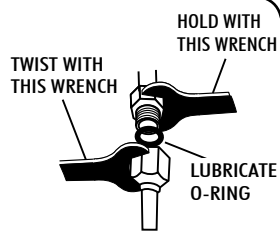

FIGURE 7b



FOR A PROPER SEAL OF FITTINGS - INSTALL SUPPLIED O-RINGS AS SHOWN AND LUBRICATE WITH SUPPLIED OIL.

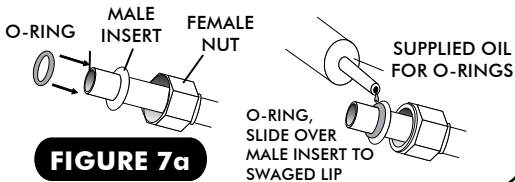
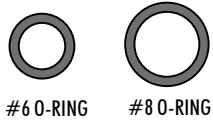

FIGURE 7a



- ❑ REMOVE THE FRONT FENDERWELL MOUNTING BOLT THAT GOES THROUGH THE CORE SUPPORT AS SHOWN IN FIGURE 8 BELOW. REPLACE THE BOLT USING A 5/16-18 x 1 1/4" HEX BOLT WITH WASHER.
- ❑ INSTALL DRIER WITH MOUNTING BRACKET ON FENDERWELL BOLT, SECURE USING 5/16-18 NUT. SEE FIGURE 8 BELOW.

NOTE: ONLY HAND TIGHTEN THE DRIER MOUNTING BRACKET NUT.

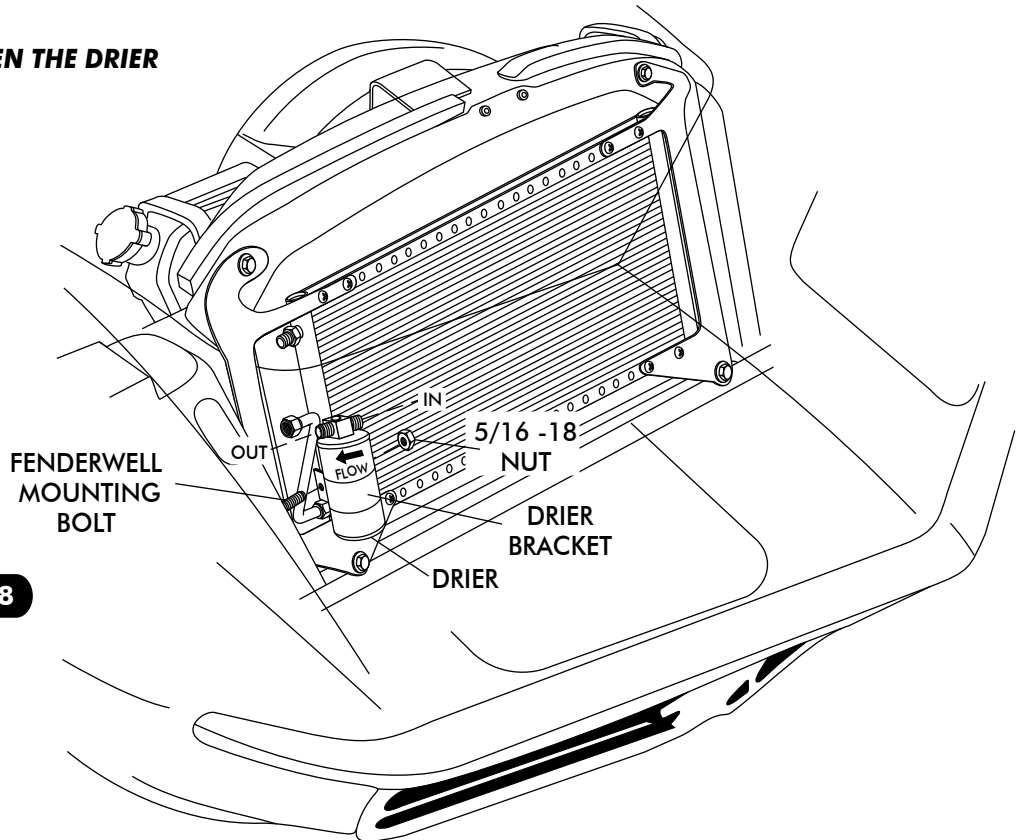

FIGURE 8

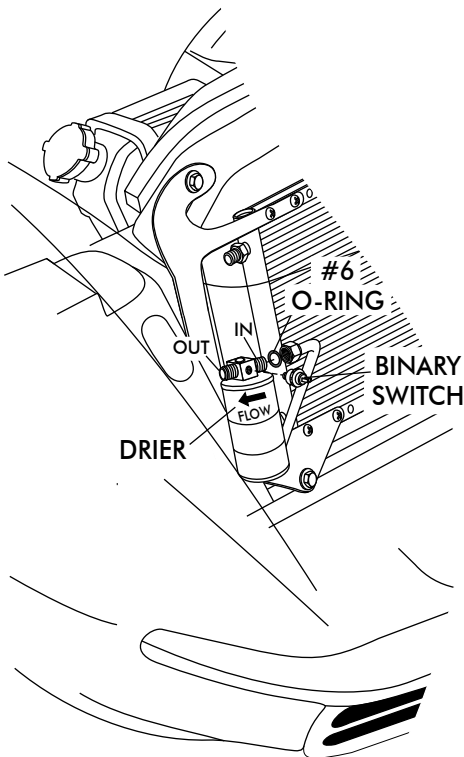

FIGURE 9

- ❑ LUBRICATE A #6 O-RING (SEE FIGURE 7a, PAGE 8) AND CONNECT THE #6 CONDENSER TO DRIER HARDLINE TO THE DRIER AS SHOWN IN FIGURE 9 BELOW. **NOTE: ONLY HAND TIGHTEN THE #6 HARDLINE.**
- ❑ INSTALL BINARY SWITCH ON DRIER AS SHOWN IN FIGURE 9.



- ❑ LUBRICATE A #8 O-RING (SEE FIGURE 7a, PAGE 8) AND CONNECT THE #8 CONDENSER-CORE SUPPORT HARDLINE TO THE CONDENSER AS SHOWN IN FIGURE 10 BELOW.
- ❑ LUBRICATE A #6 O-RING (SEE FIGURE 7a, PAGE 8) AND CONNECT THE #6 DRIER-CORE SUPPORT HARDLINE TO THE DRIER AS SHOWN IN FIGURE 10 BELOW.
- ❑ ONCE ALL HARDLINES ARE PROPERLY ATTACHED TIGHTEN THE DRIER MOUNTING BRACKET NUT AND ALL HARDLINE CONNECTIONS AS SHOWN FIGURE 7a, PAGE 8.

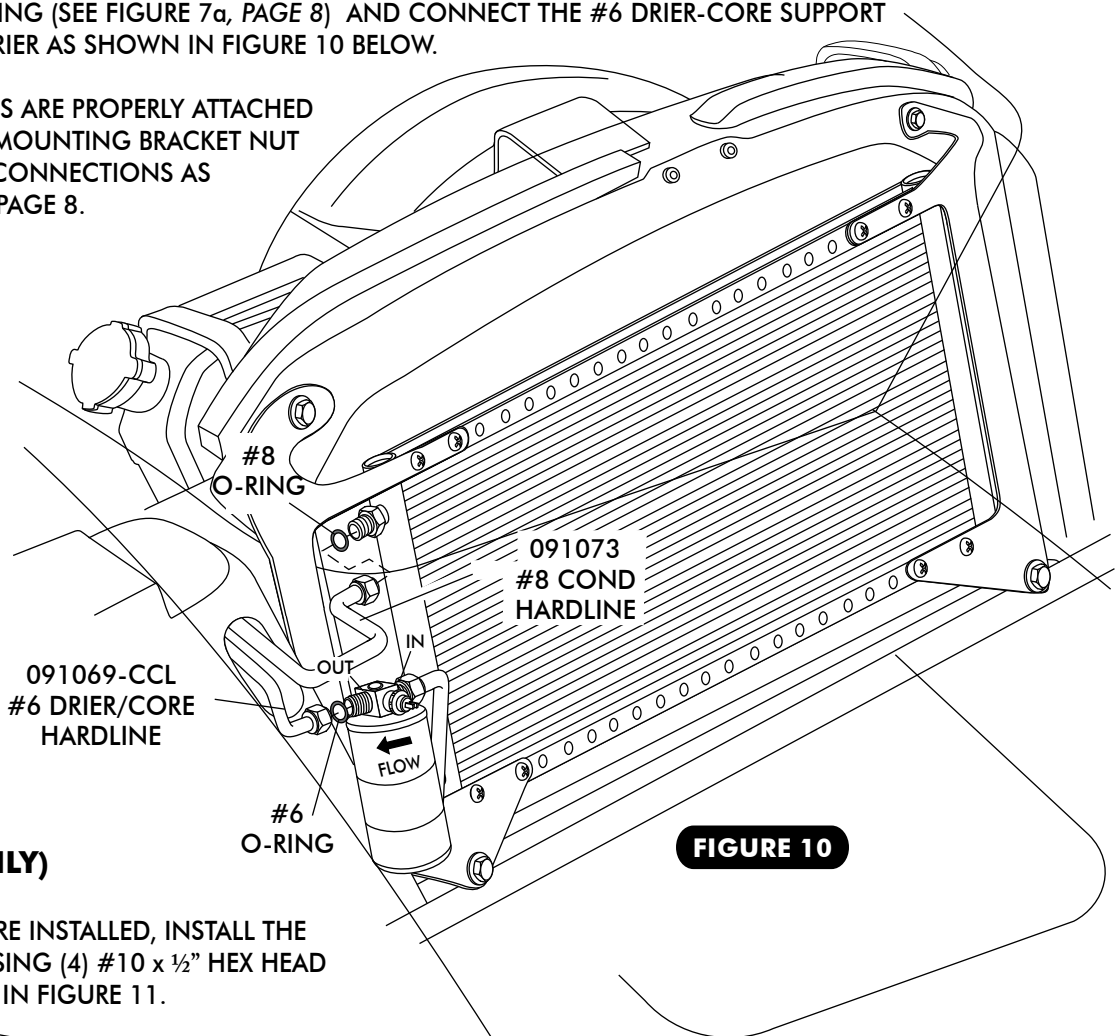

FIGURE 10

**HARDLINE COVER
INSTALLATION
(NON-AIR CARS ONLY)**

- ❑ ONCE HARDLINES ARE INSTALLED, INSTALL THE HARDLINE COVER USING (4) #10 x 1/2" HEX HEAD SCREWS AS SHOWN IN FIGURE 11.

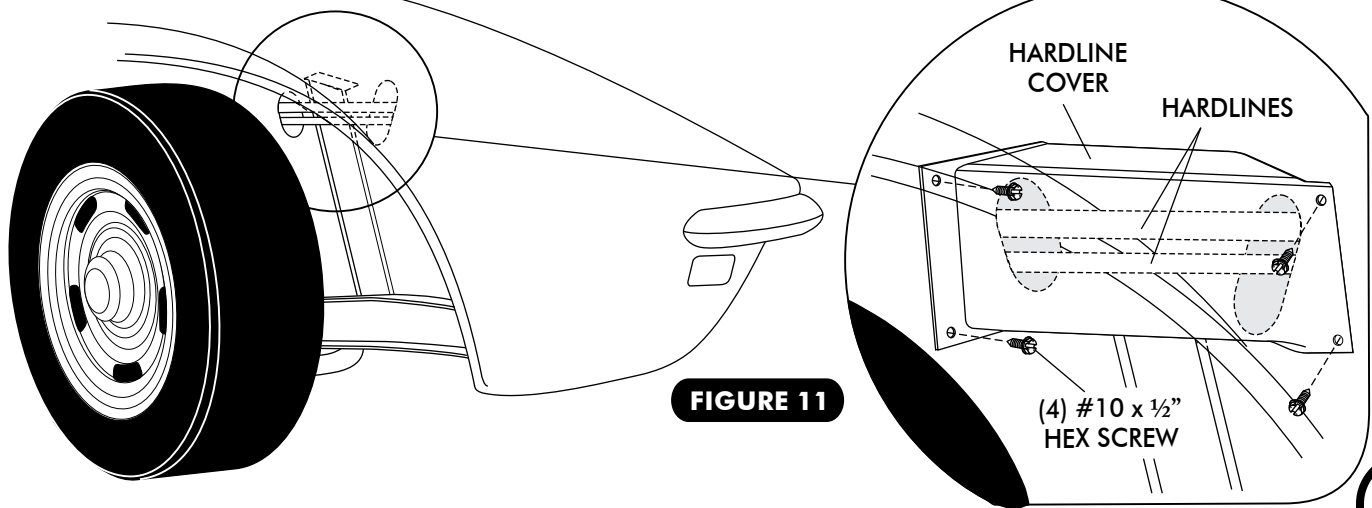
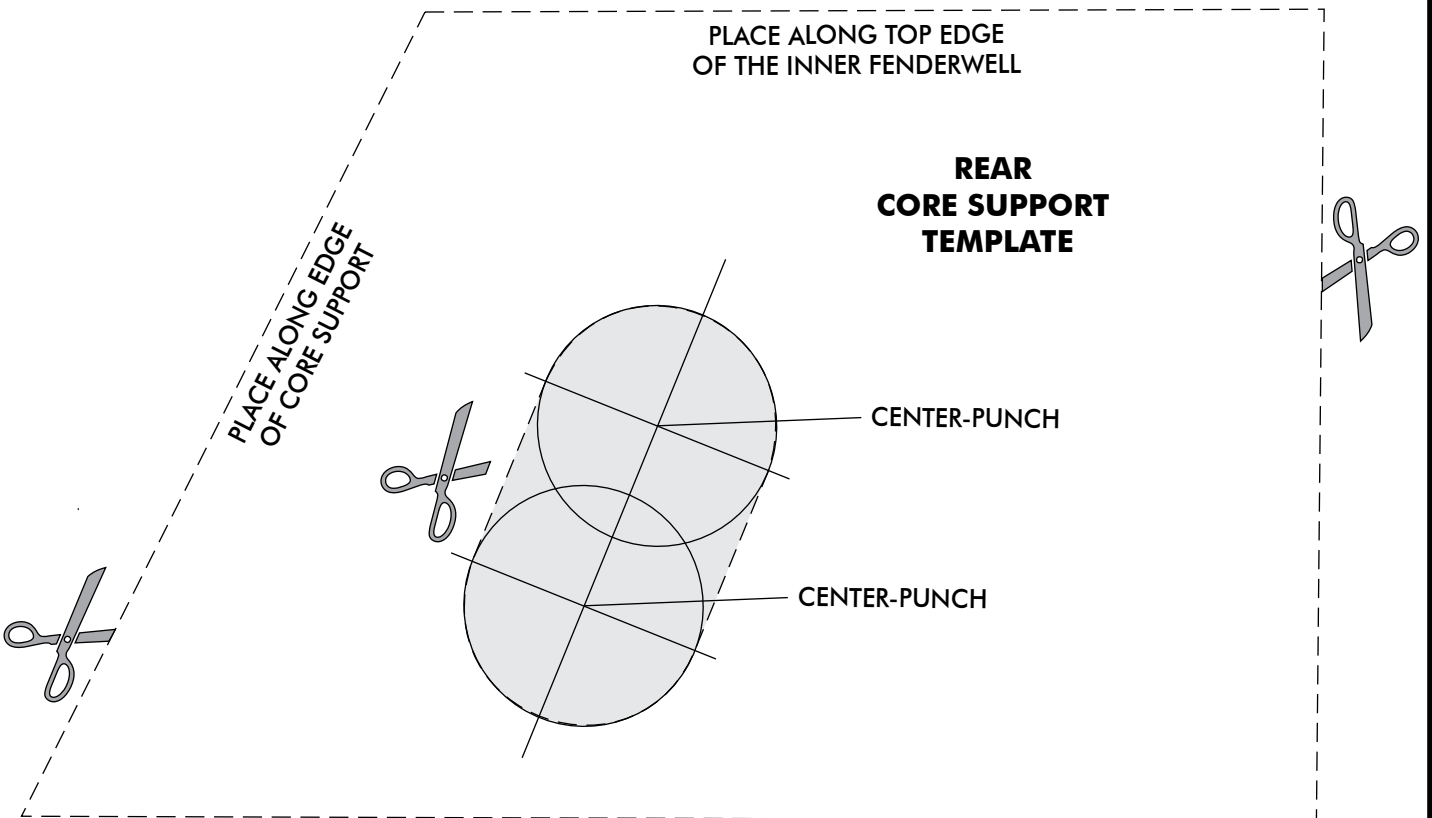
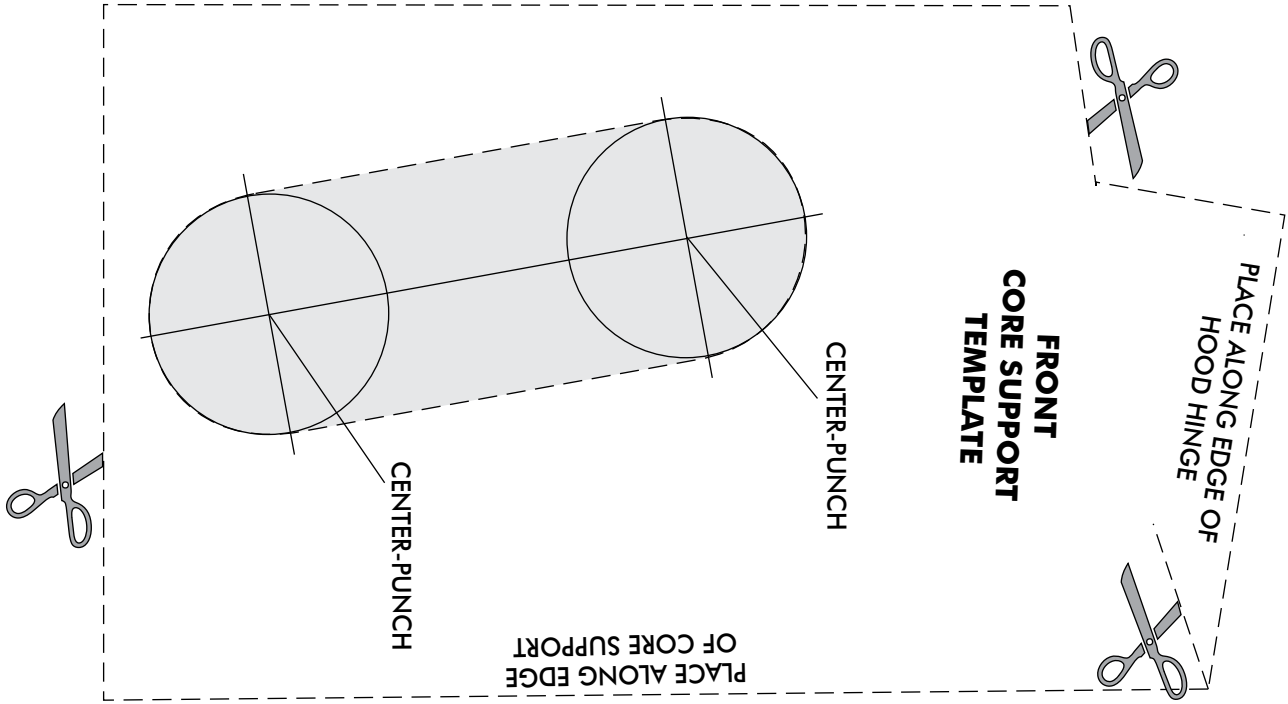

FIGURE 11



CORE SUPPORT TEMPLATE





CONDENSER KIT PACKING LIST

CONDENSER KIT
021068

No.	QTY.	PART No.	DESCRIPTION
1.	1	03767-VUC	SUPER FLOW CONDENSER 14 x 24
2.	1	07321-VUC	DRIER
3.	1	65980-VCB	DRIER CLAMP
4.	1	644077	68 VETTE DS COND BRKT
5.	1	644076	68 VETTE PS COND BRKT
6.	1	091072	HARDLINE 68 VETTE #6 COND/DRIER
7.	1	091069-CCL	68-72 VETTE #6 DRIER/CORE HARDLINE
8.	1	091073	HARDLINE 68 VETTE #8 COND
9.	1	620069-CCE	68-72 HARDLINE COVER
10.	8	18260-VUB	10-24 NUT w/ STAR WASHER
11.	8	18249-VUB	10-24 x 3/8" PAN HEAD SCREW
12.	3	33857-VUF	#6 O-RING
13.	1	33858-VUF	#8 O-RING
14.	4	18247-VUB	#10 x 1/2" HEX SCREW
15.	2	33143-VUI	CATERPILLAR GROMMET
16.	1	18151-VUB	5/16" NYLON NUT
17.	1	11079-VUS	MALE BINARY SWITCH
18.	1	23135-VUW	COMPRESSOR LEAD
19.	1	183009-DSR	5/16-18 x 1 1/4" HEX BOLT

CHECKED BY: _____
 PACKED BY: _____
 DATE: _____

