

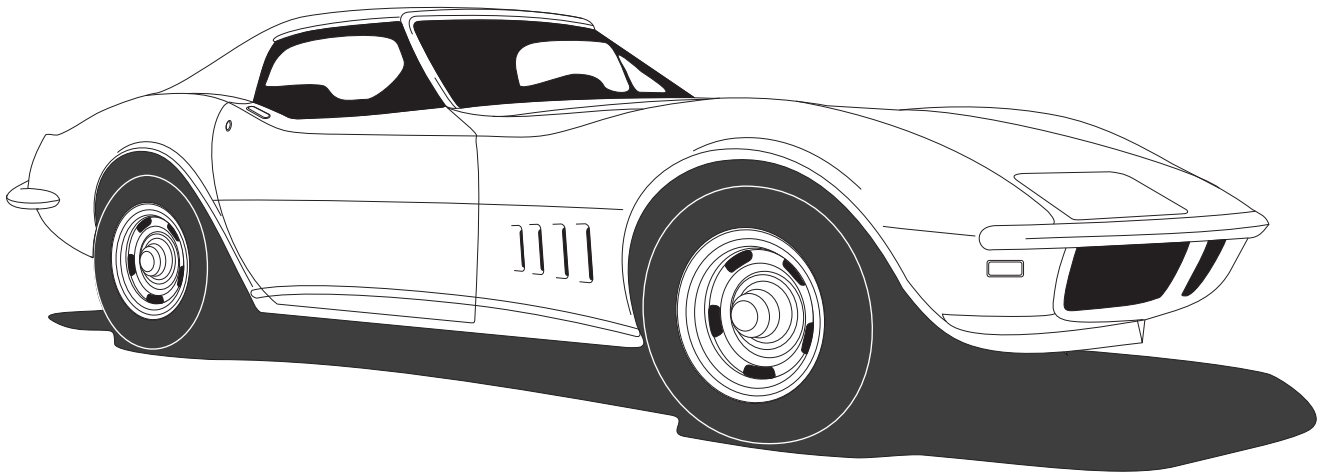

1969-76 CORVETTE

**CONDENSER KIT w/o DRIER
027069-CCA**



18865 GOLL ST. - SAN ANTONIO, TX. - 78266 ph.210-654-7171 - fax 210-654-3113



Table of Contents

PAGES

1. COVER
2. TABLE OF CONTENTS
3. PACKING LIST/PARTS DISCLAIMER
4. CONDENSER BRACKET INSTALLATION
FIGURE 1
5. CONDENSER INSTALLATION
FIGURE 2
6. CONDENSER KIT PACKING LIST



1969-76 CORVETTE CONDENSER w/o DRIER

CONDENSER KIT 027069-CCA

CONDENSER KIT PACKING LIST

No.	QTY.	PART No.	DESCRIPTION
1.	1	03767-VUC	SUPER FLOW CONDENSER 14 x 24
2.	1	644069-PCB	69-76 VETTE DS COND BRKT
3.	1	644068-PCB	69-76 VETTE PS COND BRKT
4.	8	18260-VUB	10/24 NUT w/ STAR WASHER
5.	8	18249-VUB	10-24 x 3/8" PAN HEAD SCREW

**** BEFORE BEGINNING INSTALLATION OPEN ALL PACKAGES AND CHECK CONTENTS OF SHIPMENT. PLEASE REPORT ANY SHORTAGES DIRECTLY TO VINTAGE AIR WITHIN 15 DAYS. AFTER 15 DAYS, VINTAGE AIR WILL NOT BE RESPONSIBLE FOR MISSING OR DAMAGED ITEMS.**

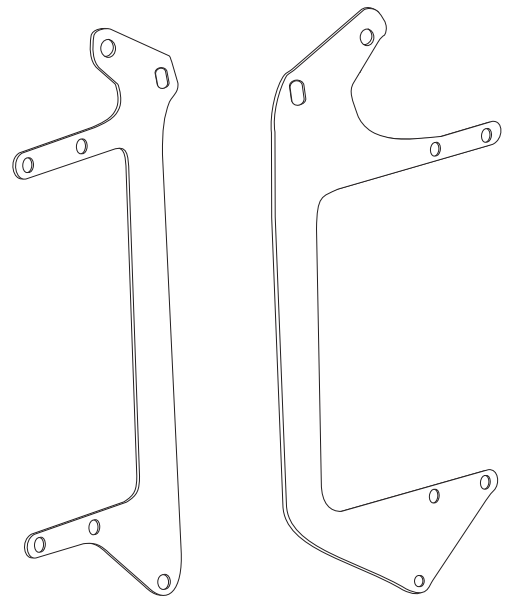
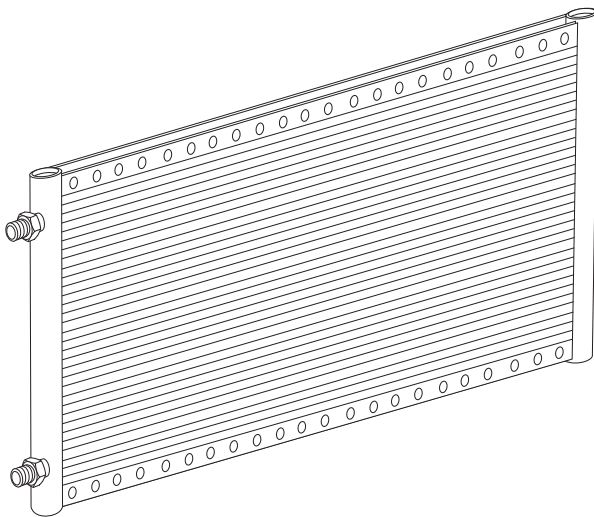



1969-76 CORVETTE CONDENSER w/o DRIER

CONDENSER BRACKET INSTALLATION

TOP VIEW

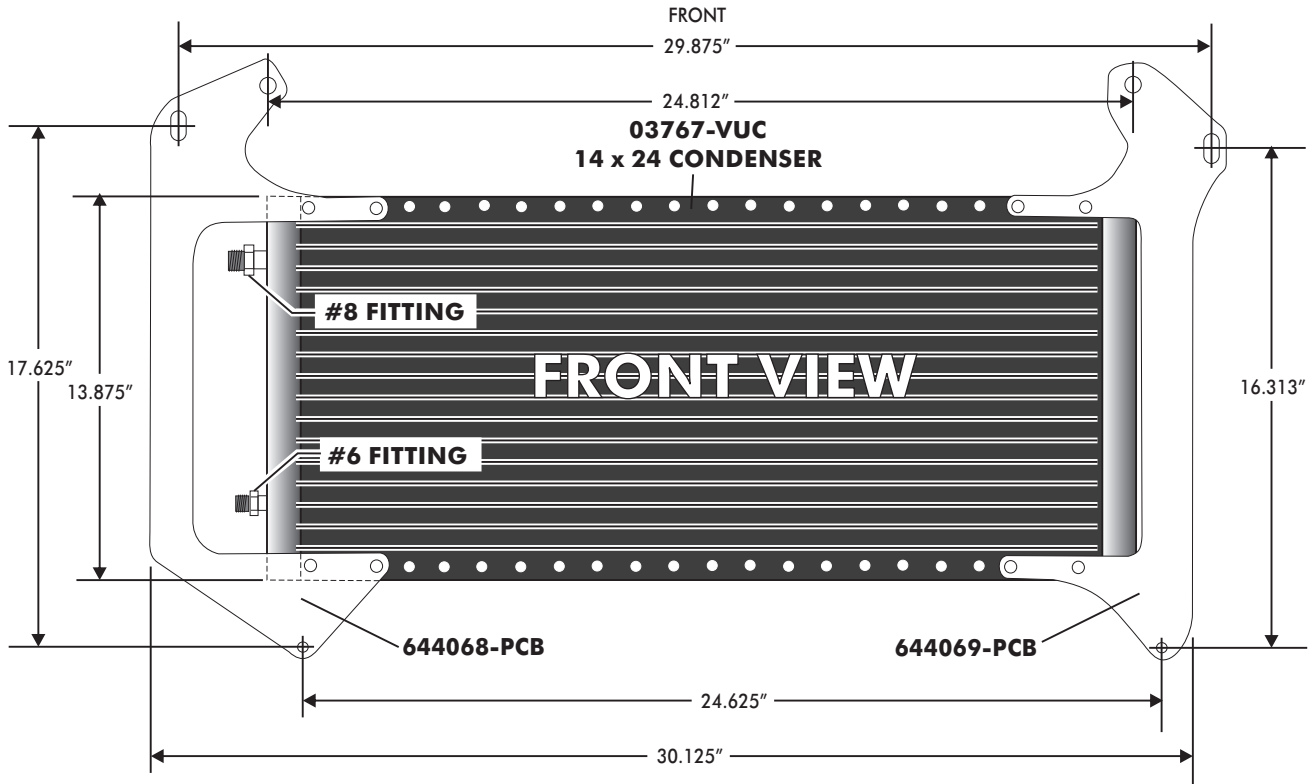
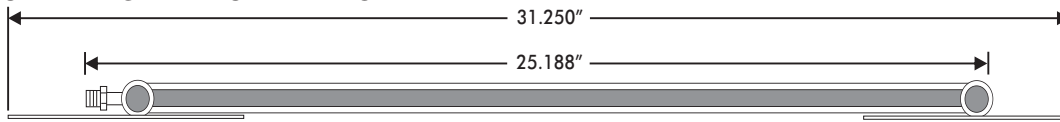

MOUNTING BRACKET INSTALLATION

□ INSTALL CONDENSER MOUNTING BRACKET ON TO CONDENSER USING (8) 10/24 x 3/8 PAN HEAD SCREWS AND (8) 10/24 NUTS WITH STAR WASHERS. SEE FIGURE 1 BELOW.

NOTE: BRACKETS MOUNT THROUGH THE FIRST AND THIRD HOLE IN THE CONDENSER.

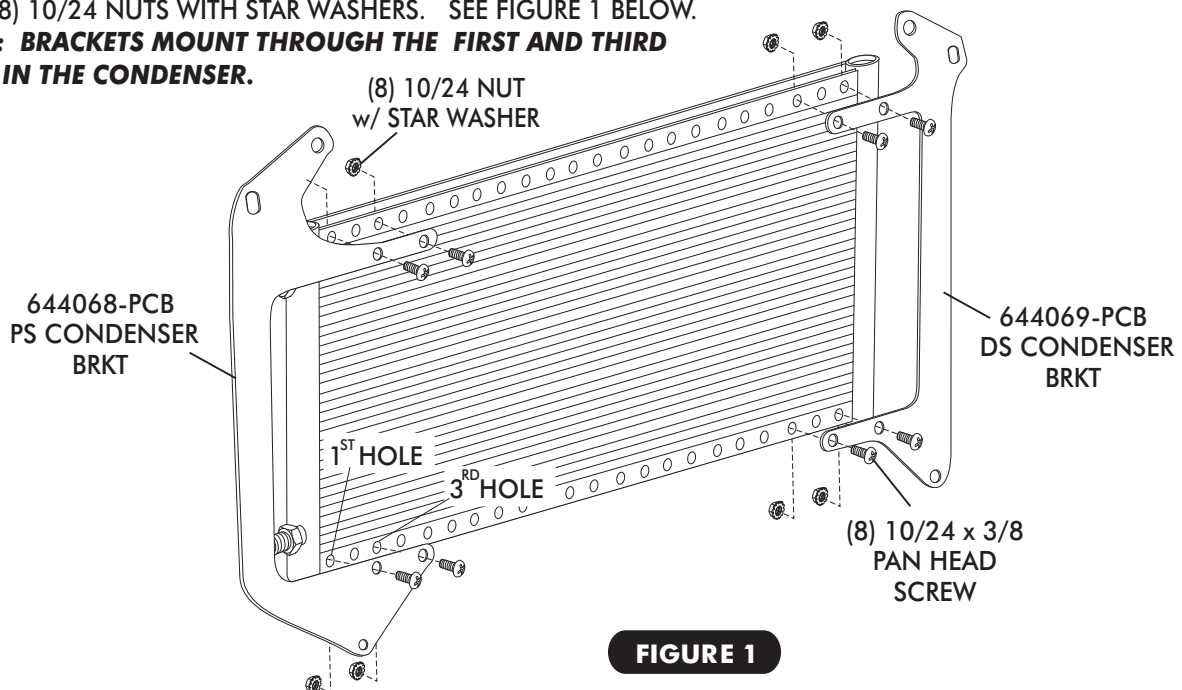

FIGURE 1



ENGINE COMPARTMENT

CONDENSER INSTALLATION

- REMOVE OEM CONDENSER AND LINES IF EQUIP WITH FACTORY AIR. (RETAIN MOUNTING HARDWARE)
- INSTALL CONDENSER ASSEMBLY BY PLACING THE CONDENSER ON THE FRONT SIDE OF THE CORE SUPPORT AND ALIGN WITH OEM MOUNTING HOLES AS SHOWN IN FIGURE 2.

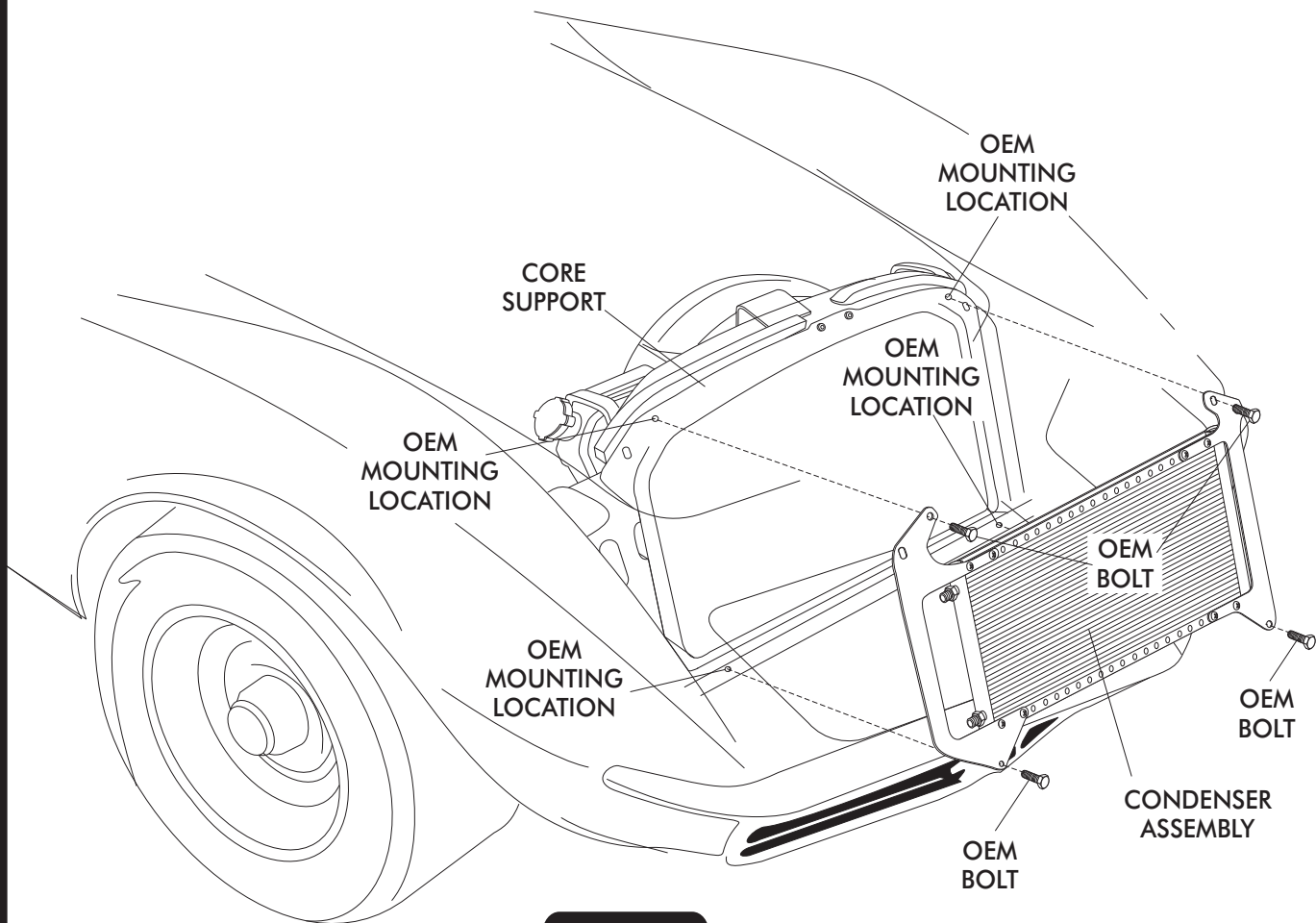

FIGURE 2



1969-76 CORVETTE CONDENSER w/o DRIER

CONDENSER KIT
027069-CCA

CONDENSER KIT PACKING LIST

No.	QTY.	PART No.	DESCRIPTION	
1.	1	03767-VUC	SUPER FLOW CONDENSER 14 x 24	_____
2.	1	644069-PCB	69-76 VETTE DS COND BRKT	_____
3.	1	644068-PCB	69-76 VETTE PS COND BRKT	_____
4.	8	18260-VUB	10/24 NUT w/ STAR WASHER	_____
5.	8	18249-VUB	10-24 x 3/8" PAN HEAD SCREW	_____

CHECKED BY: _____
 PACKED BY: _____
 DATE: _____

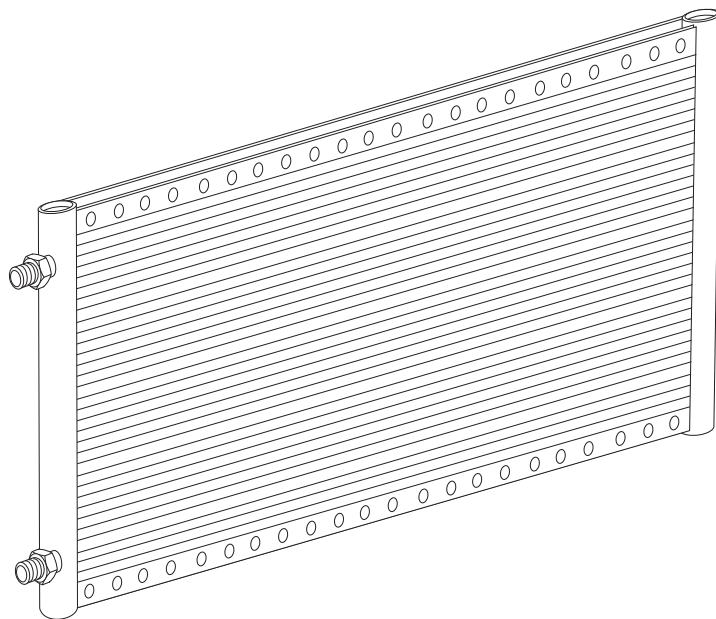

①

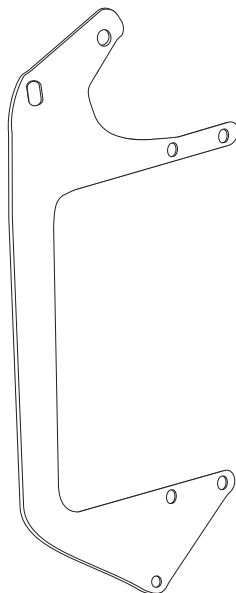

③

②

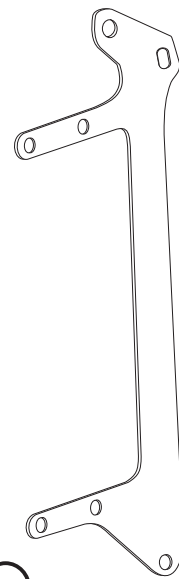

④



⑤

