

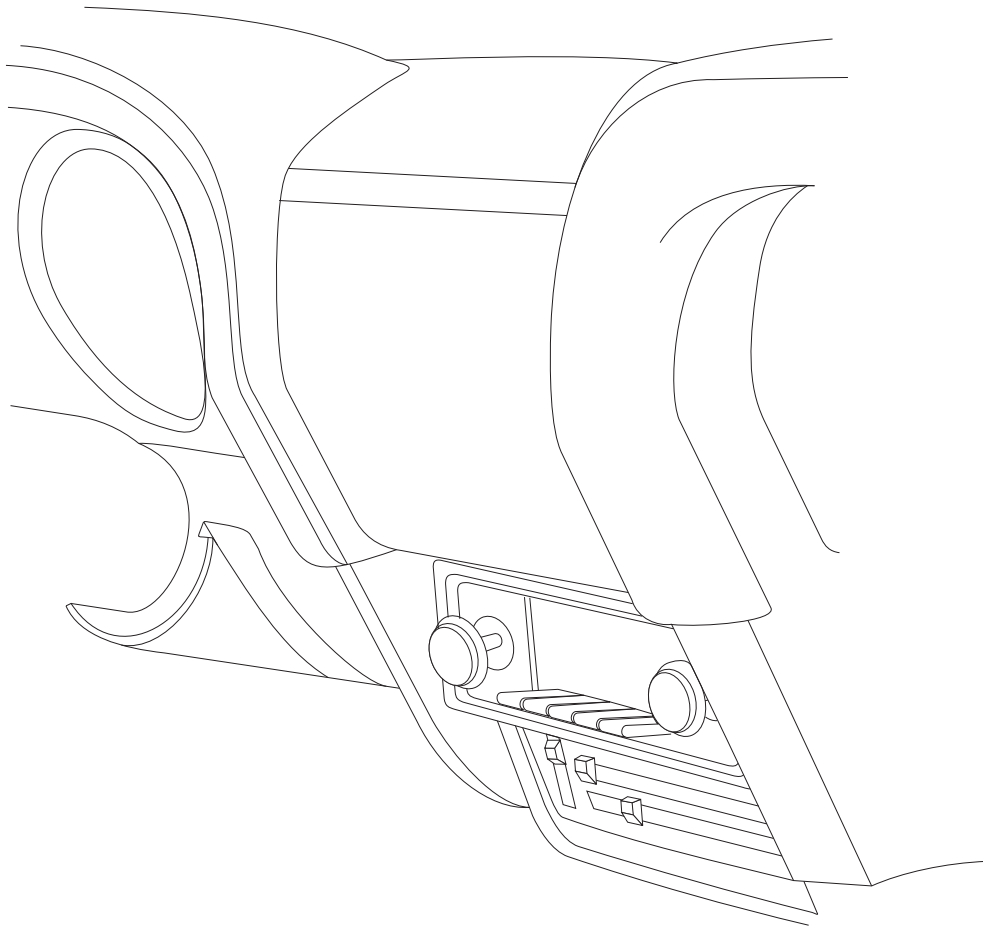

1969-70 MUSTANG

w/o AC CONTROL PANEL
CONVERSION KIT
474170



18865 GOLL ST. - SAN ANTONIO, TX. - 78266 ph.210-654-7171 - fax 210-654-3113



Table of Contents

PAGES

1. COVER
2. TABLE OF CONTENTS
3. PACKING LIST/ PARTS DISCLAIMER
4. REMOVING OEM CONTROL PANEL & PLACARD INSTALLATION
FIGURES 1,2 & 2a
5. SLIDE POT ASM MODIFICATIONS & SLIDE POT ASM MOUNTING
CLAMP INSTALLATION.
FIGURES 3 & 4
6. SLIDE POT MOUNTING HOLE MODIFICATION AND DASH/ FLR/ DEF SLIDE
POT ASM INSTALLATION
FIGURES 5 & 6
7. SLIDE POT ASM INSTALLATION CONT.
FIGURES 7 & 8
8. COLD/ HOT SLIDE POT MOUNTING HOLE MODIFICATION AND SLIDE
POT ASM INSTALLATION
FIGURES 9 & 10
9. SLIDE POT ASM INSTALLATION CONT.
FIGURES 11 & 12
10. BLOWER SWITCH & SECURING WIRING HARNESS
FIGURES 13 & 14
11. FINAL STEPS
FIGURE 15
12. CONTROL PANEL CALIBRATION PROCEDURE
13. WIRING DIAGRAM
14. OPERATION OF CONTROLS
15. CONTROL PANEL KIT PACKING LIST



1969-70 MUSTANG w/o AC CNTRL PNL

CONTROL KIT PACKING LIST

**CONTROL KIT
474170**

No.	QTY.	PART No.	DESCRIPTION
1.	1	484075	69-70 MUSTANG CNTRL PNL MODE LABEL ASM
2.	2	112002-SUA	SLIDE POT ASM
3.	1	232006-VUR	GEN IV UNIVERSAL CONTROL HARNESS (TYPE B)
4.	2	65976-VUE	3/16 PUSH-ON RING
5.	2	491010-VUR	SLIDE POT CLAMP
6.	5	21301-VUP	4 TIE WRAP
7.	3	18247-VUB	#10 X 1/2 SHEET METAL SCREW
8.	1	231520	GROUND WIRE
9.	1	18058-VUB	5/16 NYLON CABLE CLAMP
10.	1	246110-PUA	BLOWER SWITCH PC BOARD

**** BEFORE BEGINNING INSTALLATION OPEN ALL PACKAGES AND CHECK CONTENTS OF SHIPMENT. PLEASE REPORT ANY SHORTAGES DIRECTLY TO VINTAGE AIR WITHIN 15 DAYS. AFTER 15 DAYS, VINTAGE AIR WILL NOT BE RESPONSIBLE FOR MISSING OR DAMAGED ITEMS.**

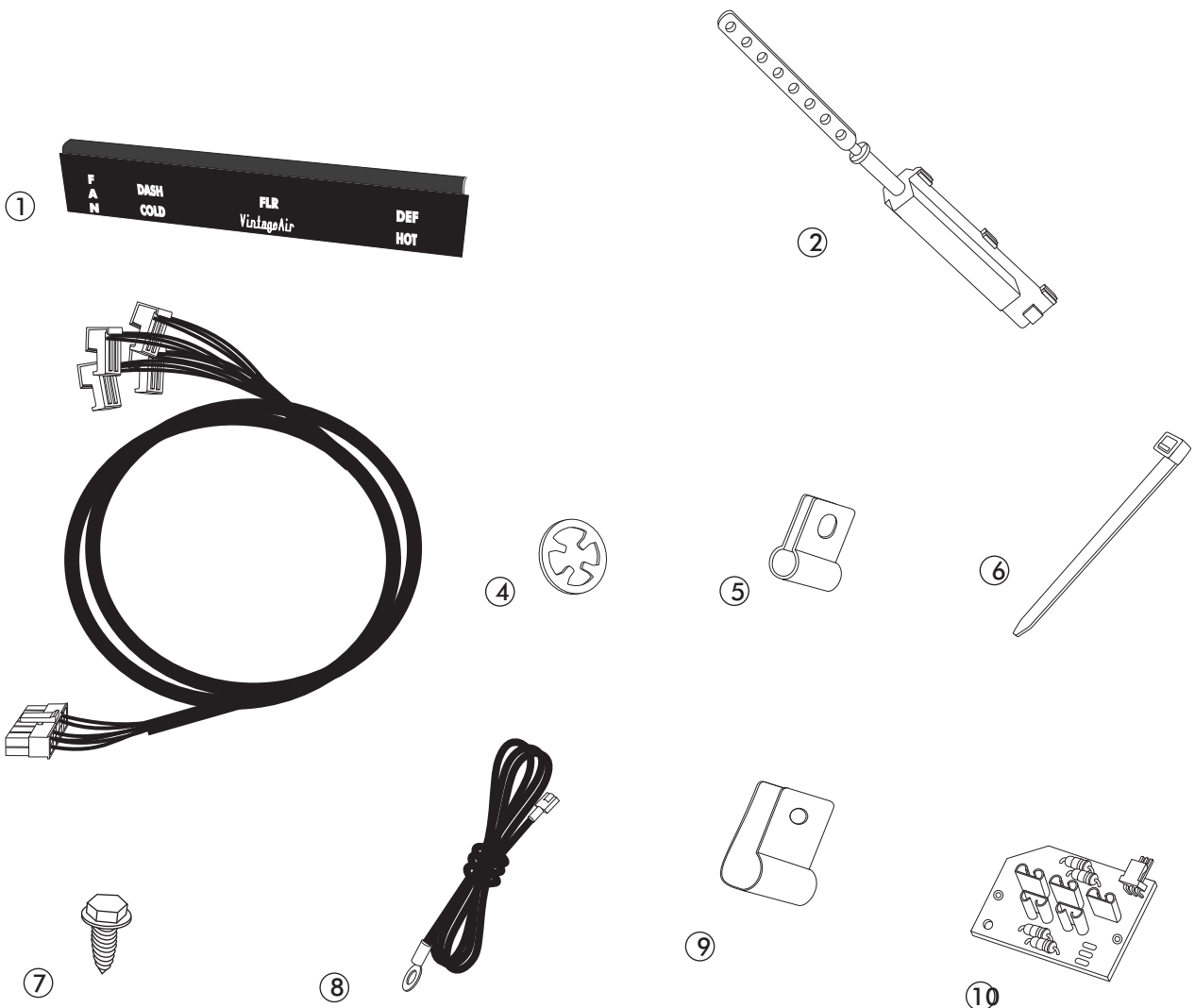



1969-70 MUSTANG w/o AC CNTRL PNL

REMOVING OEM CONTROL PANEL

- REMOVE THE (3) OEM MOUNTING SCREWS FROM CONTROL PANEL. SEE FIGURE 1
- REMOVE THE CONTROL PANEL
- DISCONNECT CABLES, AND WIRES FROM BACK OF CONTROL PANEL.

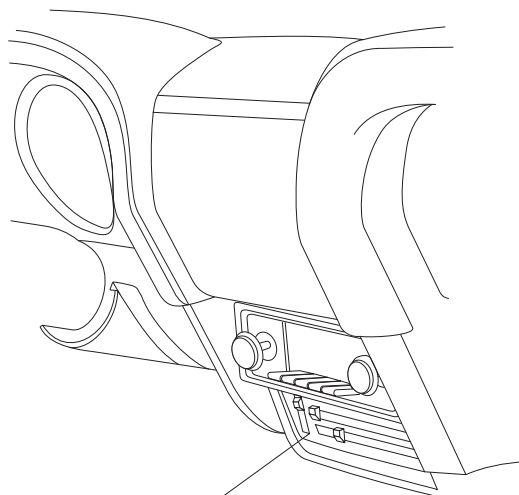

CONTROL PANEL

FIGURE 1

PLACARD INSTALLATION

- REMOVE KNOBS.
- REMOVE OEM LENS AND BRKT FROM CONTROL PANEL.
- INSTALL CONTROL PANEL MODE LABEL ASM AS SHOWN IN FIGURE 2a.
- RE-INSTALL OEM BEZEL AND KNOBS.

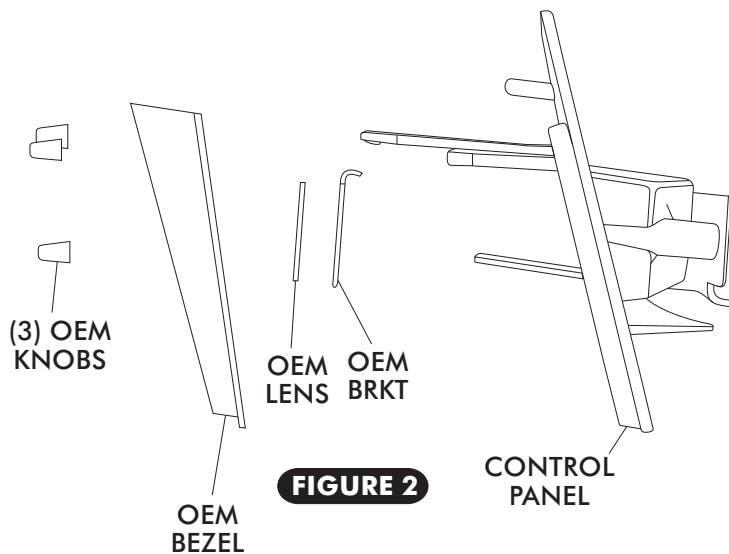

FIGURE 2

CONTROL PANEL

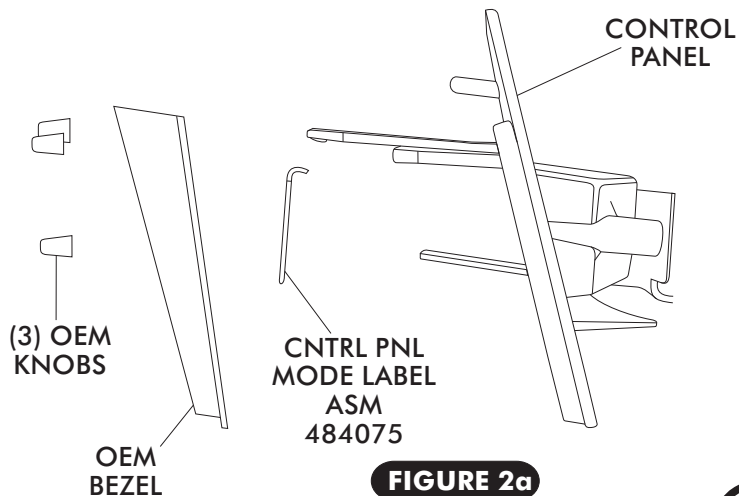

FIGURE 2a



1969-70 MUSTANG w/o AC CNTRL PNL

SLIDE POT ASSEMBLY MODIFICATIONS

- LOCATE THE (2) SLIDE POT ASSEMBLIES, AND USING A PAIR OF WIRE CUTTERS, CUT SLIDE POT ACTUATOR RODS AS SHOWN BELOW IN FIGURE 3.

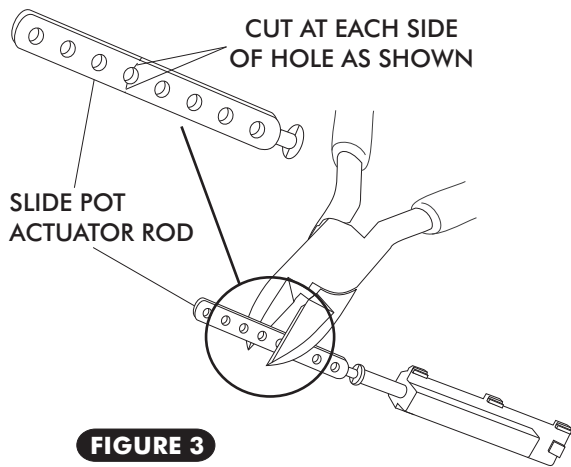

COLD/HOT LEVER
CUT AT 6TH HOLE
(REMOVE SHADED PORTION)

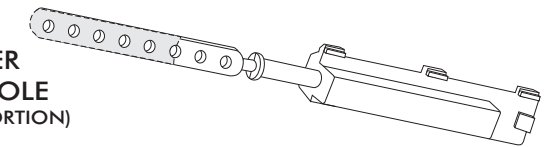

DASH/ FLR/ DEF LEVER
CUT AT 7TH HOLE
(REMOVE SHADED PORTION)

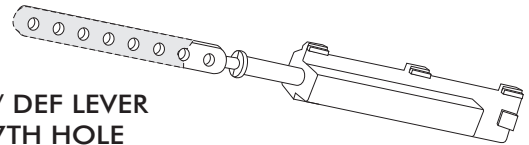

FIGURE 3

SLIDE POT ASSEMBLY MOUNTING CLAMP INSTALLATION

- INSTALL SLIDE POT ASM MOUNTING CLAMPS, SEE FIGURE 4 BELOW.

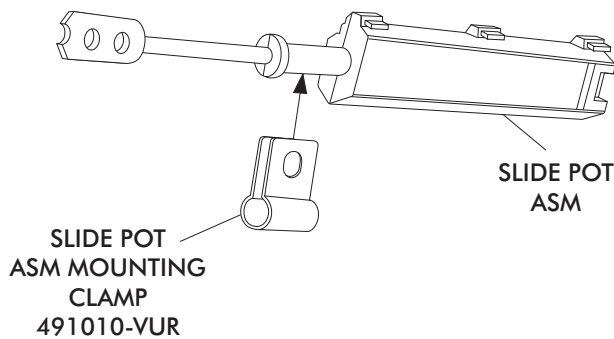
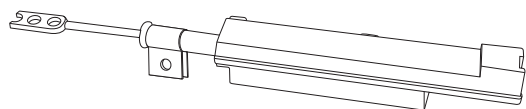
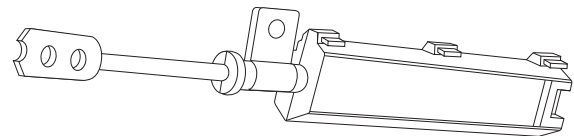
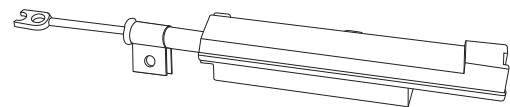

FIGURE 4



COLD/HOT
SLIDE POT ASSEMBLY
112002-SUA



DASH/ FLR/ DEF
POT ASSEMBLY
112002-SUA

ORIENT SLIDE POT ASSEMBLIES AS SHOWN AND INSTALL MOUNTING CLAMPS AS SHOWN. (NOTE ORIENT CLAMPS IN RELATION TO THE (3) HOUSING SNAPS ON SLIDE POT ASSEMBLY.)



DASH/ FLR/ DEF SLIDE POT MOUNTING HOLE MODIFICATION

- DRILL 1/8 HOLE IN CONTROL PANEL AS SHOWN IN FIGURE 5 BELOW.

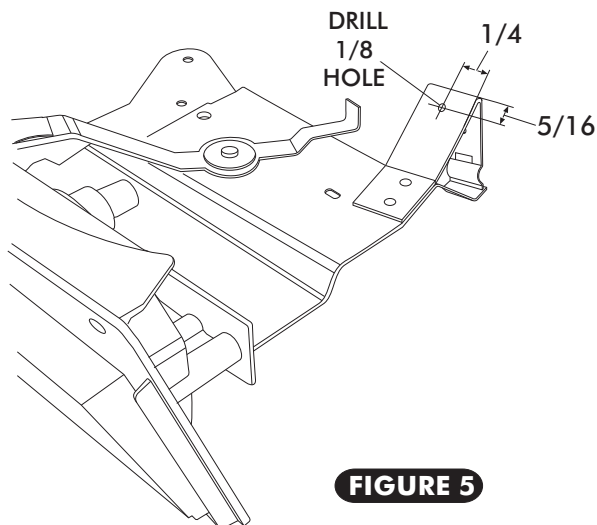
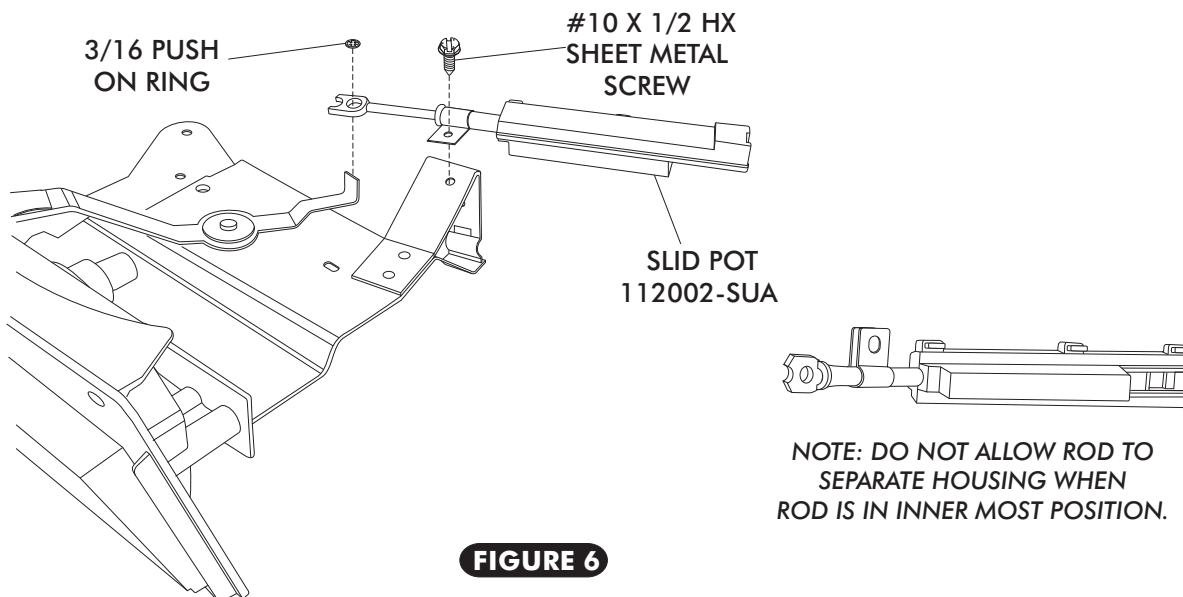

FIGURE 5

SLIDE POT ASSEMBLY INSTALLATION

DASH/ FLR/ DEF SLIDE POT ASSEMBLY

- INSTALL SLIDE POT ASM ON THE DASH/FLR/ DEF LEVER. SEE FIGURE 6 BELOW.
- INSTALL SLIDE POT LEVER PUSH ROD ONTO OEM CABLE MOUNTING STUD ON LEVER. SEE FIGURE 6 BELOW.
- SECURE THE SLIDE POT ASM TO THE CONTROL PANEL MOUNTING BRACKET USING A #10 X 1/2 HX SHEET METAL SCREW. SEE FIGURE 6 BELOW.
- SINCE THE SLIDE POT ASSEMBLY CAN SLIDE BACK AND FORTH IN CLAMP BEFORE SCREW IS TIGHTENED POSITION SUCH THAT THE FLAT PART OF THE ROD IS AS CLOSE TO FLUSH AS POSSIBLE WITH THE END OF HOUSING AT THE LEVERS INNER MOST POSITION. SEE FIGURE 6 BELOW.
- SECURE SLIDE POT LEVER PUSH ROD ONTO OEM CABLE MOUNTING STUD USING 3/16 PUSH-ON RING AS SHOWN IN FIGURE 6 BELOW.



NOTE: DO NOT ALLOW ROD TO SEPARATE HOUSING WHEN ROD IS IN INNER MOST POSITION.

FIGURE 6



SLIDE POT ASSEMBLY INSTALLATION CONT.

- LOCATE THE CONTROL PANEL WIRE HARNESS AND PLUG THE CORRESPONDING WIRES INTO THE CORRECT SLIDE POT ASSEMBLY AS SHOWN IN FIGURE 7 BELOW.

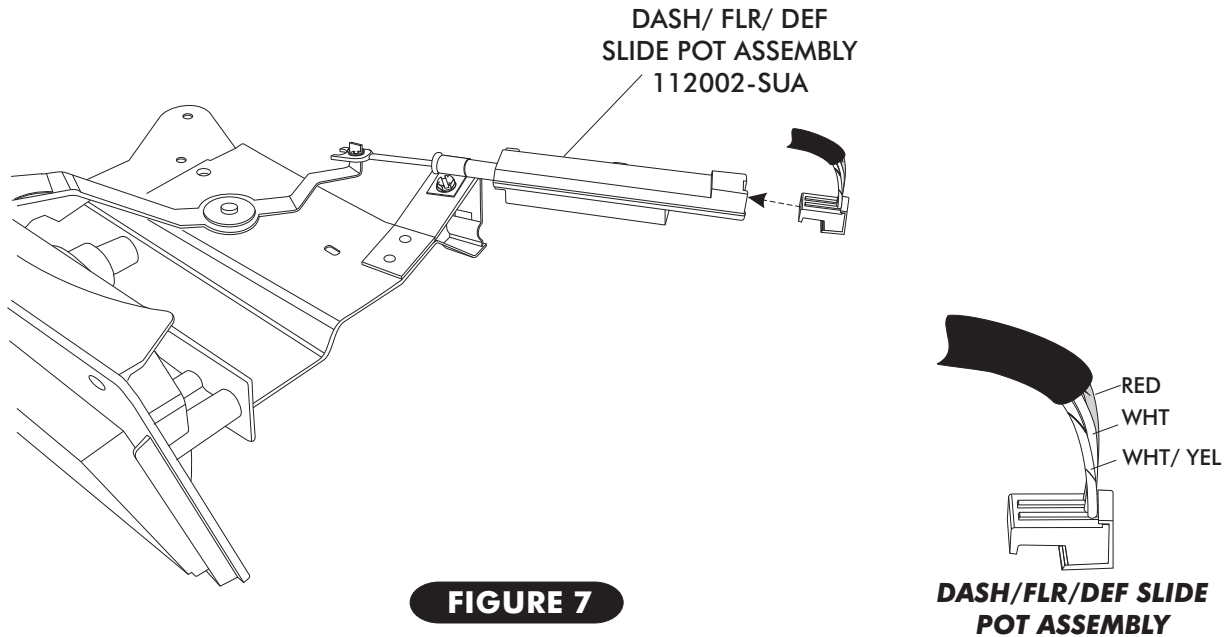

FIGURE 7

- ONCE WIRES ARE CORRECTLY PLUGGED INTO SLIDE POT ASSEMBLY, SECURE WIRES TO THE SLIDE POT ASSEMBLY USING TIE WRAPS (SUPPLIED). SEE FIGURE 8 BELOW. THE TIE WRAP MUST BE LOCATED BETWEEN THE END OF THE WIRE JACKET AND THE STEP IN THE SLIDE POT HOUSING FORCING A BEND IN EACH WIRE AS THEY PASS OVER THE STEP IN SLIDE POT HOUSING. HEAD OF TIE WRAP MUST FALL ON EDGE OF HOUSING AS SHOWN TO REMAIN TIGHT. ENSURE THAT THE TIE WRAPS ARE SNUG ENOUGH THAT THE WIRES CAN NOT MOVE. SEE FIGURE 8.

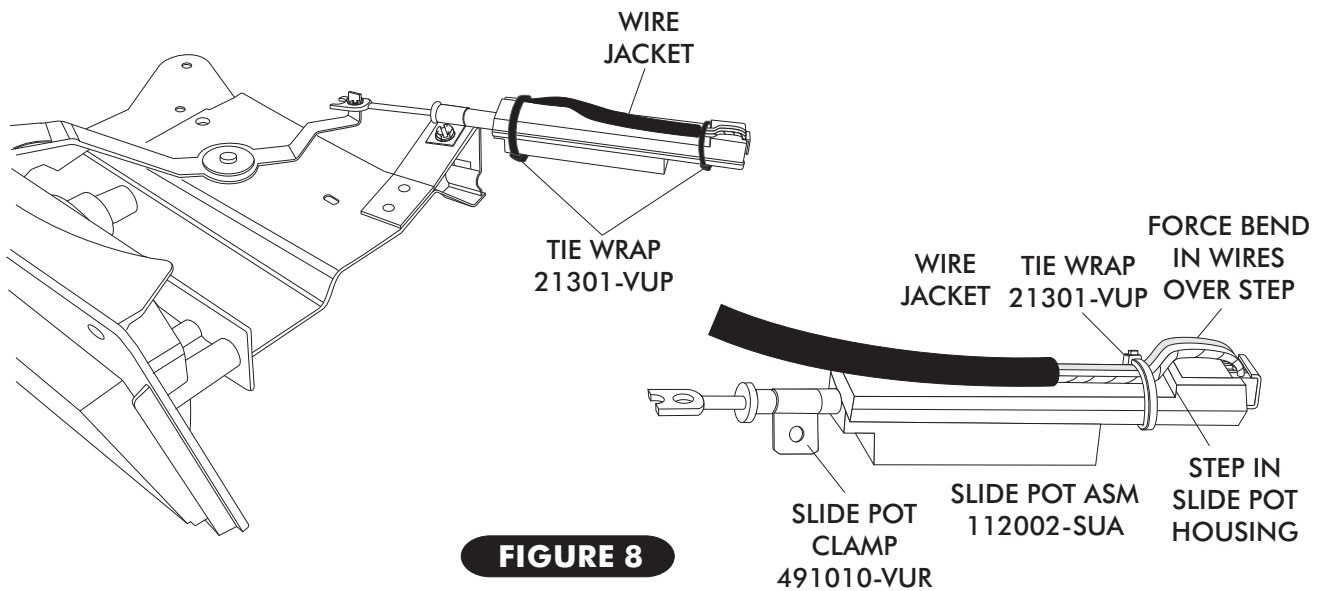

FIGURE 8



1969-70 MUSTANG w/o AC CNTRL PNL

COLD/HOT SLIDE POT MOUNTING HOLE MODIFICATION

- DRILL 1/8 HOLE IN CONTROL PANEL AS SHOWN IN FIGURE 9 BELOW.

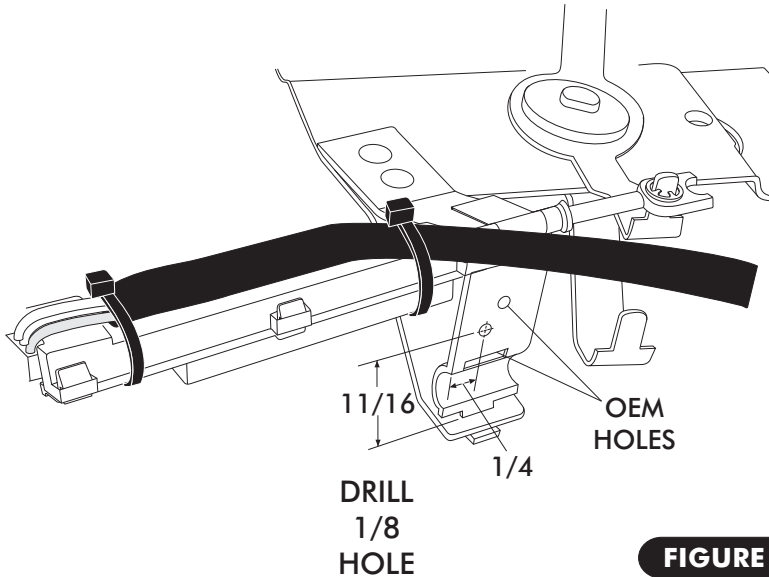
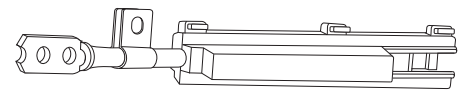
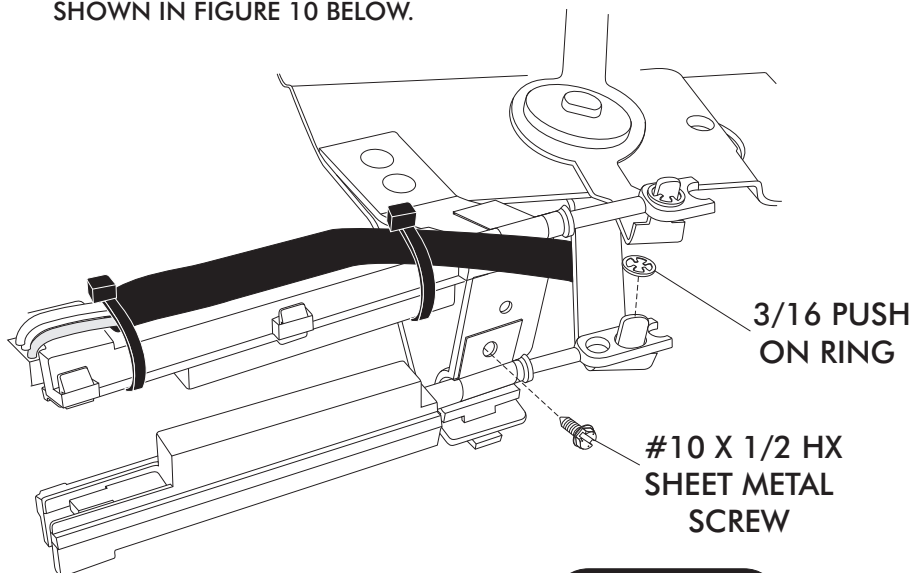

FIGURE 9

SLIDE POT ASSEMBLY INSTALLATION

COLD/HOT SLIDE POT ASSEMBLY

- INSTALL SLIDE POT ASM ON THE COLD/HOT LEVER. SEE FIGURE 10 BELOW.
- INSTALL SLIDE POT LEVER PUSH ROD ON TO OEM CABLE MOUNTING STUD ON LEVER. SEE FIGURE 10 BELOW.
- SECURE THE SLIDE POT ASM TO THE CONTROL PANEL USING A #10 X 1/2 HX SHEET METAL SCREW. SEE FIGURE 10 BELOW.
- SECURE SLIDE POT LEVER PUSH ROD ON TO OEM CABLE MOUNTING STUD USING 3/16 PUSH-ON RING AS SHOWN IN FIGURE 10 BELOW.



NOTE: DO NOT ALLOW ROD TO SEPARATE HOUSING WHEN ROD IS IN INNER MOST POSITION.

FIGURE 10



SLIDE POT ASSEMBLY INSTALLATION CONT.

- LOCATE THE CONTROL PANEL WIRE HARNESS AND PLUG THE CORRESPONDING WIRES INTO THE CORRECT SLIDE POT ASSEMBLY AS SHOWN IN FIGURE 11 BELOW.

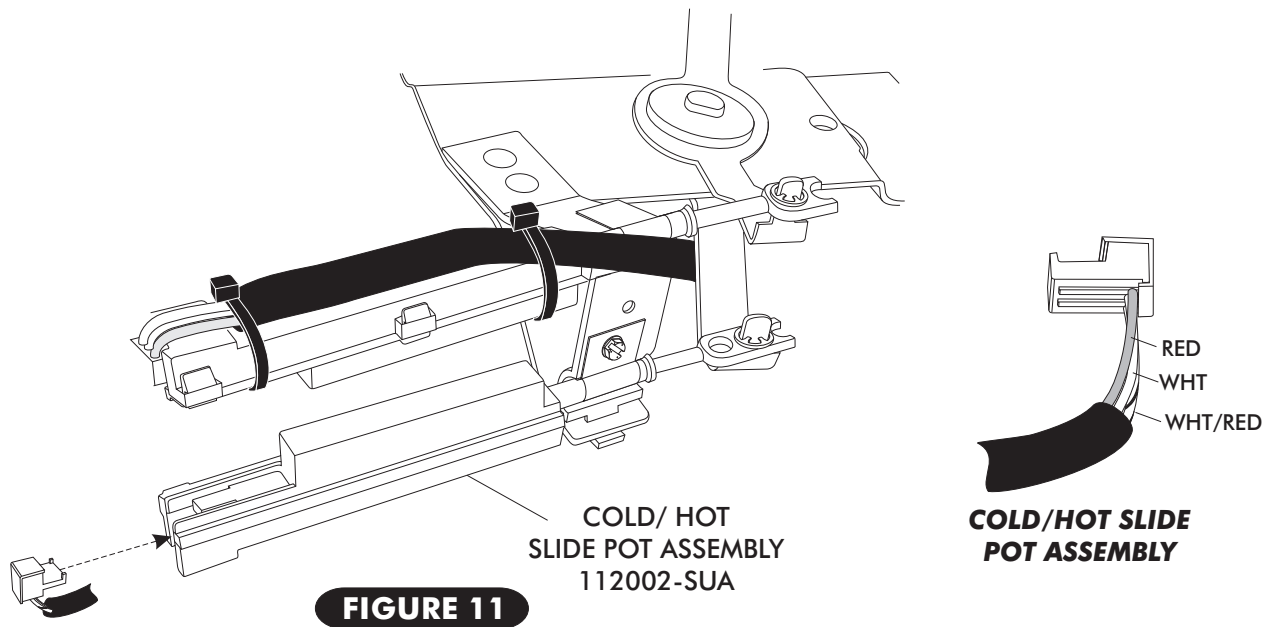

- ONCE WIRES ARE CORRECTLY PLUGGED INTO SLIDE POT ASSEMBLY, SECURE WIRES TO THE SLIDE POT ASSEMBLY USING TIE WRAPS (SUPPLIED). SEE FIGURE 12 BELOW. THE TIE WRAP MUST BE LOCATED BETWEEN THE END OF THE WIRE JACKET AND THE STEP IN THE SLIDE POT HOUSING FORCING A BEND IN EACH WIRE AS THEY PASS OVER THE STEP IN SLIDE POT HOUSING. HEAD OF TIE WRAP MUST FALL ON EDGE OF HOUSING AS SHOWN TO REMAIN TIGHT. ENSURE THAT THE TIE WRAPS ARE SNUG ENOUGH THAT THE WIRES CAN NOT MOVE. SEE FIGURE 12.

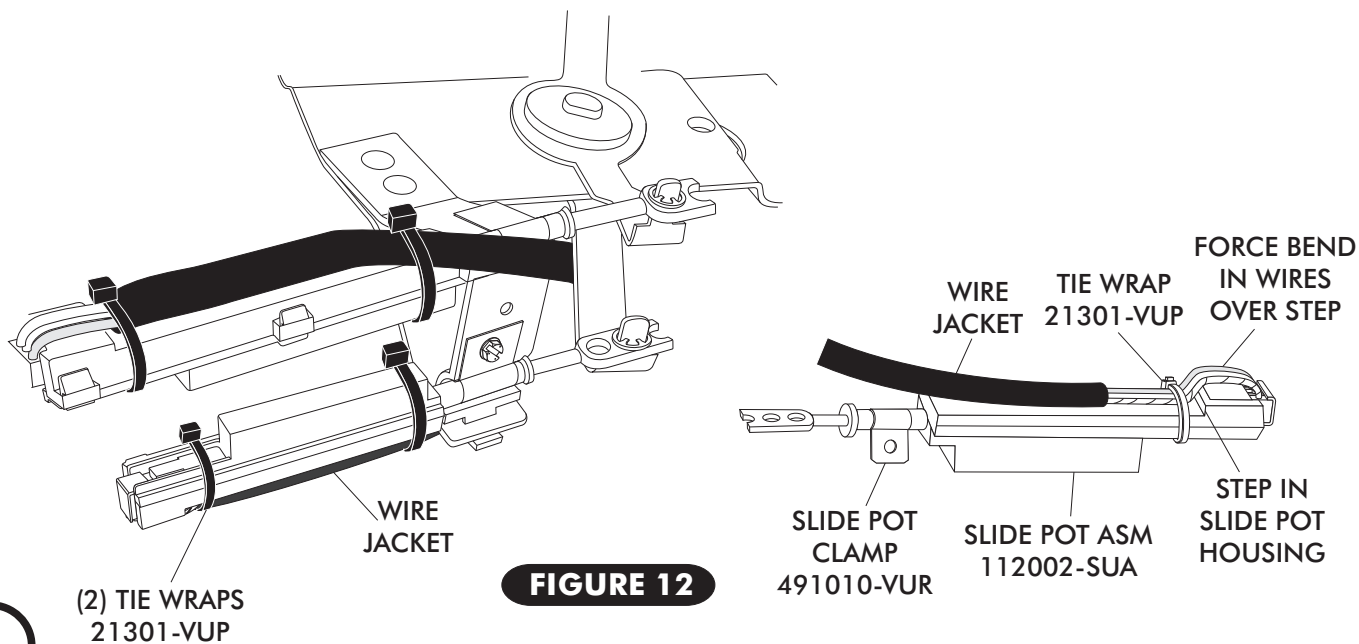



1969-70 MUSTANG w/o AC CNTRL PNL

BLOWER SWITCH

- INSTALL THE BLOWER SWITCH PC BOARD ON O.E.M. BLOWER SWITCH AS SHOWN IN FIGURE 13 BELOW.
- PLUG IN THE REMAINING CONNECTOR WITH THE RED, WHT & WHT/GRN WIRES INTO THE BLOWER SWITCH PC BOARD AS SHOWN IN FIGURE 13 BELOW.

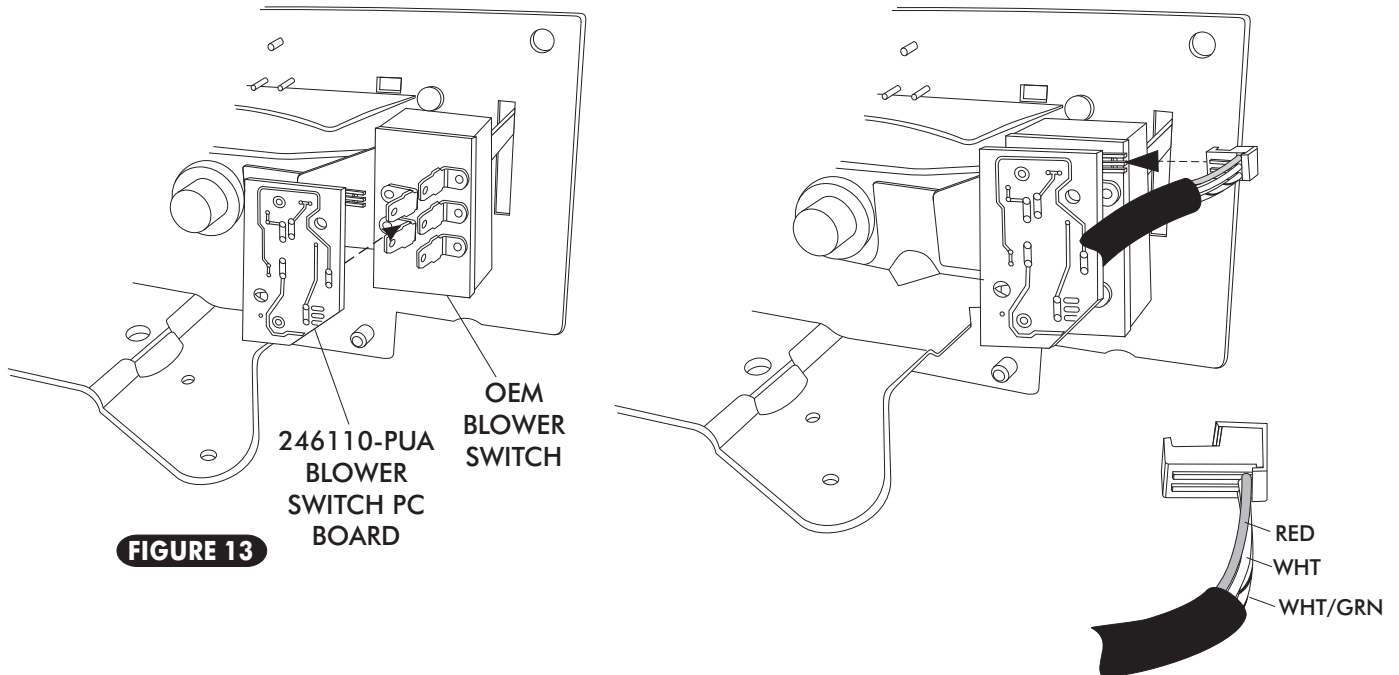

FIGURE 13

SECURING WIRING HARNESS

- SECURE THE WIRING HARNESS TO THE CONTROL PANEL USING A 5/16 NYLON CLAMP AND #10 X 1/2 HX SHEET METAL SCREW. SEE FIGURE 14 BELOW.
- USING THE SUPPLIED TIE-WRAPS, TIE THE WIRES AND THE UNUSED WIRE TO THE CONTROL PANEL AS SHOWN IN FIGURE 14 BELOW. CONFIRM THAT WIRES ARE SECURE AND DO NOT INTERFERE WITH LEVER OPERATION OR SLIDE POT ASSEMBLY.

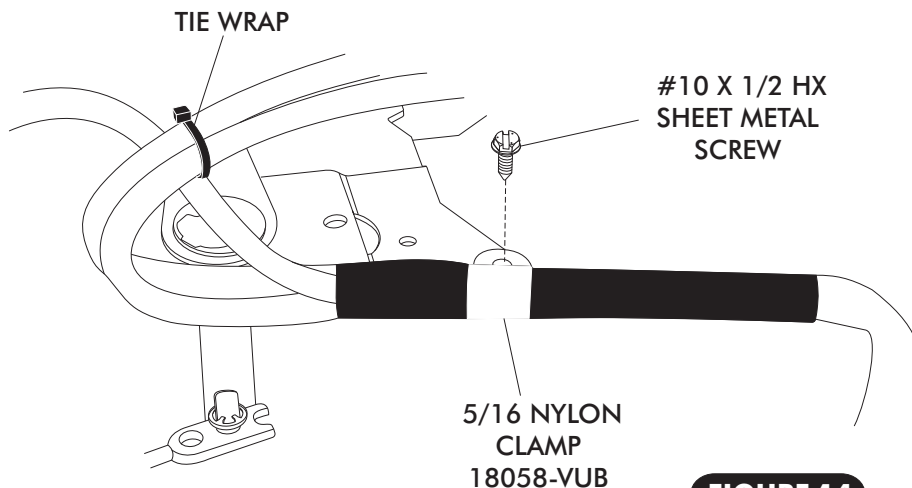

FIGURE 14



1969-70 MUSTANG w/o AC CNTRL PNL

FINAL STEPS

- INSTALL CONTROL PANEL IN DASH. TO EASE INSTALLATION, ROTATE CONTROL PANEL SLIGHTLY AND PASS THE SLIDE POT ASSEMBLIES THROUGH DASH OPENING FIRST. AS THE SLIDE POT ASSEMBLIES PASS THROUGH THE DASH OPENING ROTATE THE CONTROL PANEL BACK THE OPPOSITE DIRECTION TO FIT CONTROL PANEL IN DASH. **NOTE: MAKE SURE SLIDE POT ASSEMBLIES CLEAR DUCT HOSE BEHIND THE DASH OPENING. DO NOT FORCE THE CONTROL PANEL IN DASH, FORCING THE CONTROL PANEL IN DASH WILL DAMAGE SLIDE POT ASSEMBLIES AND/OR DUCT HOSE.**
- PLUG THE WIRING HARNESS INTO THE ECU MODULE ON SUB CASE. SEE FIGURE 15 BELOW.
- WIRE ACCORDING TO WIRING DIAGRAM ON PAGE 13.
- CALIBRATION PROCEDURE AND OPERATION INSTRUCTIONS:

CALIBRATING THE CONTROL PANEL WILL SET THE RANGE OF TRAVEL FOR THE SLIDE POTS CONNECTED TO THE OEM CONTROL PANEL LEVERS. PERFORMING THIS PROCEDURE WILL SET THE LIMITS OF THE SLIDE POTS AT THEIR HIGHEST AND LOWEST POINTS

LOCATE THE GRAY WIRE WITH AN UNUSED CONNECTOR IN THE WIRING HARNESS NEAR THE TWO CABLE HARNESS RELAYS. THIS WIRE IS LABELED *PRGM* ON THE WIRING DIAGRAM ON PAGE 13.

IT WILL BE NECESSARY TO GROUND THE GRAY WIRE FOR APPROXIMATELY FIVE SECONDS WHILE MOVING THE CONTROLS SO IT IS SOMETIMES HELPFUL TO ATTACH ONE END OF THE WHITE JUMPER WIRE TO THE VEHICLE'S GROUND (FOR EXAMPLE THE CHASSIS) AND HAVE THE OTHER END READY TO CONNECT TO THE GRAY *PRGM* WIRE WHEN THE PROCEDURE REQUIRES IT.

TO CALIBRATE THE CONTROL PANEL FOLLOW THE CALIBRATION PROCEDURES ON PAGE 12.

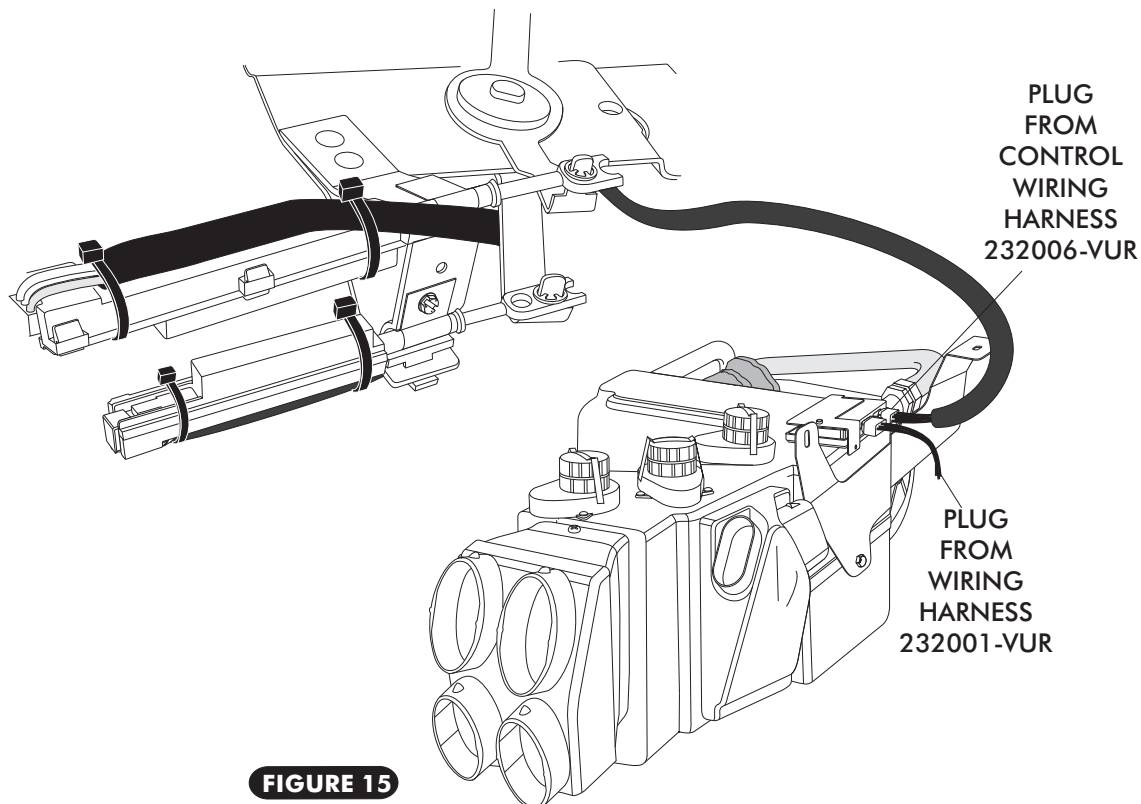

FIGURE 15



1969-70 MUSTANG w/o AC CNTRL PNL

CONTROL PANEL CALIBRATION PROCEDURE

1. TURN THE IGNITION SWITCH ON (DO NOT START THE ENGINE)
2. CONNECT THE WHITE JUMPER WIRE TO VEHICLE'S GROUND (FOR EXAMPLE THE VEHICLE CHASSIS). ENSURE THAT THE GRAY WIRE IS NOT GROUNDED. DO NOT CONNECT JUMPER WIRE TO THE GRAY PRGM WIRE. SEE FIGURE A, BELOW.

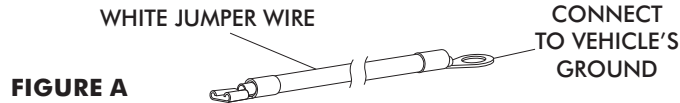

FIGURE A

3. MOVE ALL OF THE CONTROL LEVERS TO THEIR MAXIMUM POSITIONS, AS SHOWN IN FIGURE B, BELOW.

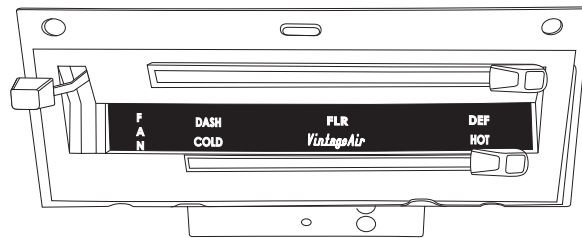

FIGURE B

4. GROUND THE GRAY WIRE BY CONNECTING THE GRAY PRGM WIRE & WHITE JUMPER WIRE FOR APPROXIMATELY 5 SECONDS (THE BLOWER WILL CHANGE SPEEDS WHEN STEP FOUR IS COMPLETE). SEE FIGURE C, BELOW.

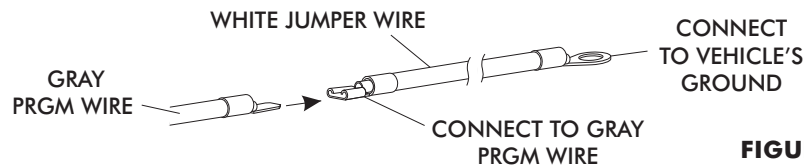

FIGURE C

5. LEAVING THE GRAY WIRE GROUNDED, MOVE ALL OF THE CONTROL LEVERS TO THEIR MINIMUM POSITIONS AS SHOWN IN FIGURE D BELOW.

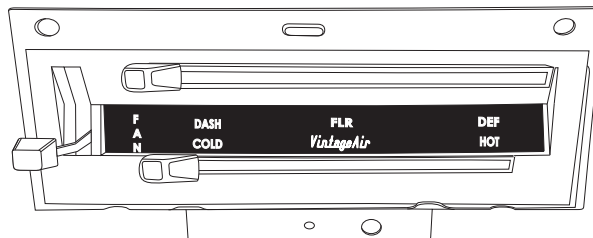

FIGURE D

6. DISCONNECT THE GRAY WIRE FROM THE WHITE GROUND JUMPER WIRE (THE BLOWER WILL CHANGE SPEEDS WHEN STEP SIX IS COMPLETE). SEE FIGURE E, BELOW.

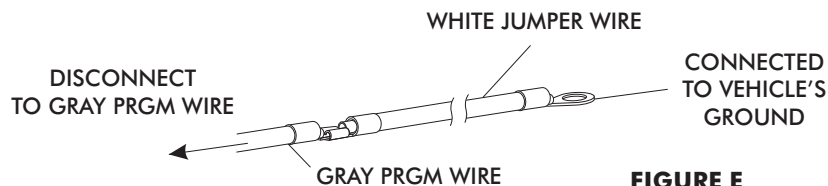

FIGURE E

7. START THE ENGINE AND TEST ALL OF THE CONTROLS TO ENSURE THAT THE INTENDED RESULTS WERE ACCOMPLISHED.

8. DISCONNECT THE WHITE JUMPER WIRE FROM VEHICLE'S GROUND.

NOTE: THIS PROCEDURE MAY BE REPEATED IF NECESSARY.

*** WHEN FINISHED, TAPE OVER PROGRAM WIRE CONNECTOR WITH ELECTRICAL TAPE TO PREVENT ACCIDENTAL CONTACT WITH CHASSIS GROUND.**



1969-70 MUSTANG w/o AC CNTRL PNL

WIRING DIAGRAM

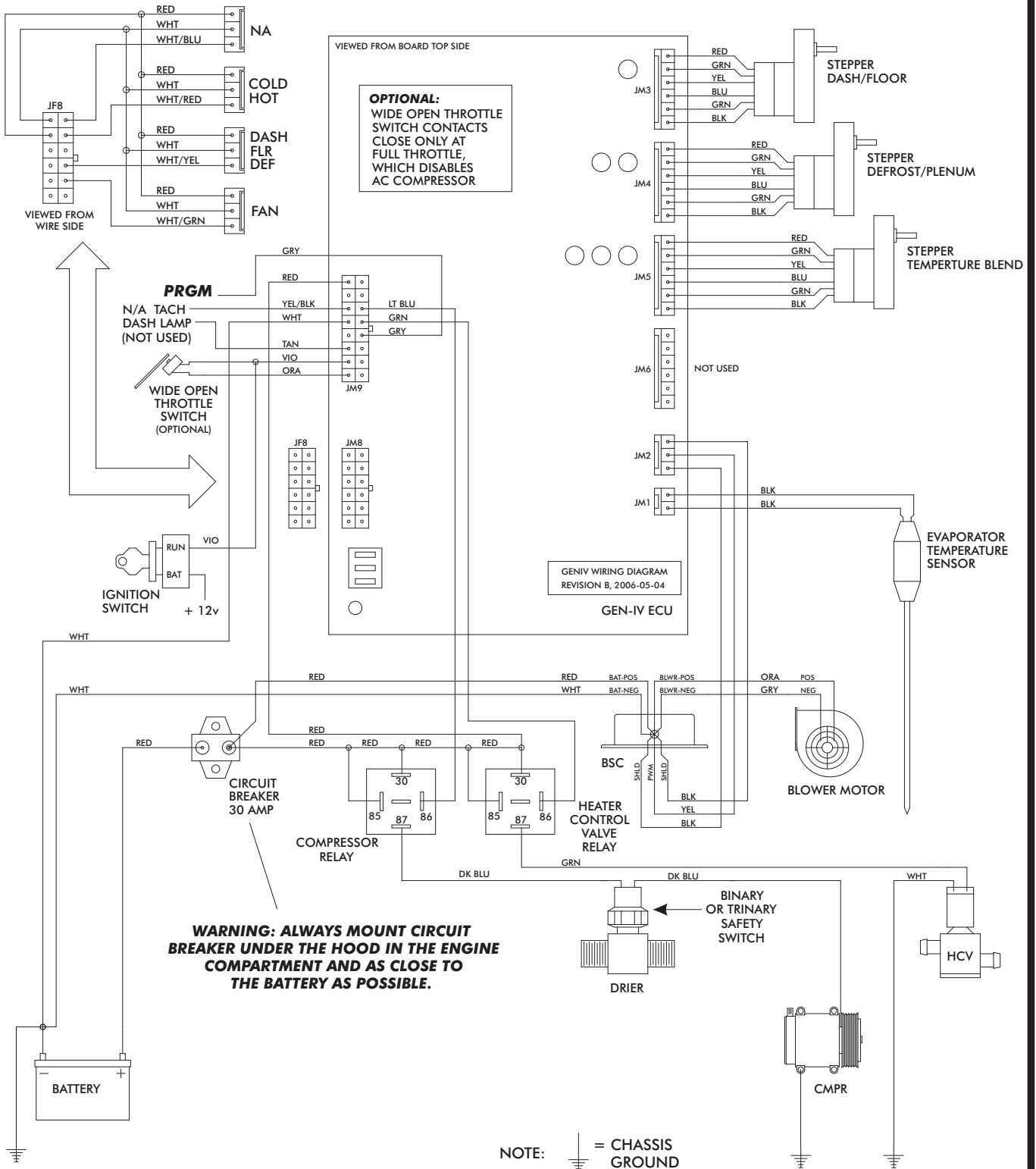



1969-70 MUSTANG w/o AC CNTRL PNL

OPERATION OF CONTROLS

NOTE:

WHEN BATTERY POWER IS FIRST CONNECTED TO THE ECU, THE COMPUTER GOES THROUGH AN INITIALIZATION SEQUENCE. THIS INITIALIZATION MAY TAKE UP TO 30 SECONDS. DURING INITIALIZATION THE BLOWER WILL NOT OPERATE, BUT THE DOORS INSIDE THE UNIT WILL BE OPERATING. A LOW BATTERY OR DISCONNECTING THE BATTERY MAY ALSO TRIGGER A RE-INITIALIZATION. DURING START UP, A LOW BATTERY MAY DROP BELOW 7 VOLTS, TRIGGERING RE-INITIALIZATION.

THE COLD LEVER TOGGLES BETWEEN COLD AND HOT MODES. FOR A/C MODE SLIDE THE COLD LEVER ALL THE WAY UP TO ENGAGE THE COMPRESSOR. SLIDE THE COLD KNOB LEVER DOWN TO SELECT DESIRED TEMPERATURE. FOR HEAT MODE SLIDE THE COLD LEVER ALL THE WAY DOWN TO DISENGAGE THE COMPRESSOR. SLIDE THE COLD LEVER UP TO TO SELECT DESIRED TEMPERATURE.

ALL SWITCHES ARE VARIABLE BETWEEN POSITIONS, SYSTEM WILL PERFORM A BLEND BETWEEN THE FUNCTIONS.

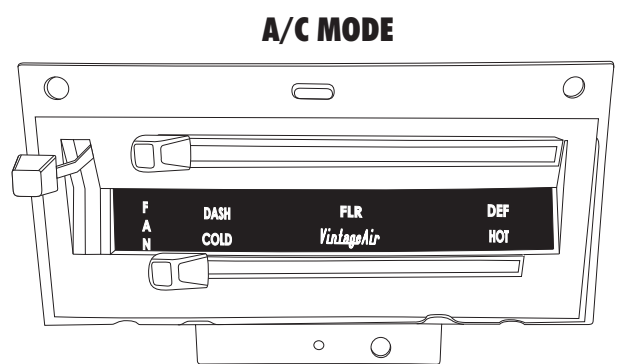
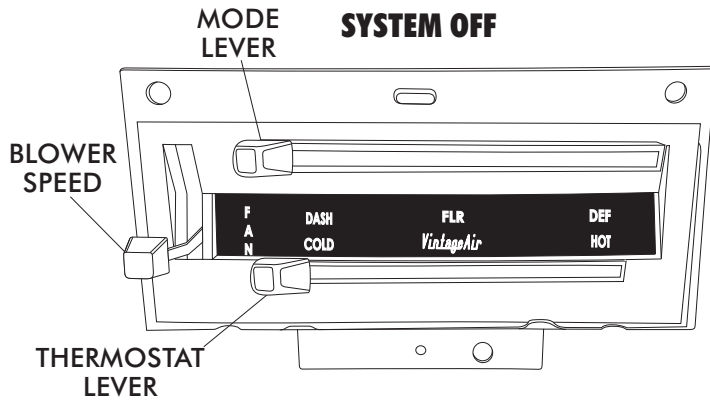

BLOWER SPEED
THIS LEVER CONTROLS THE BLOWER SPEED, FROM OFF TO HI

MODE LEVER
SLIDE THE LEVER TO THE "DASH" POSITION

THERMOSTAT LEVER
IN A/C MODE SLIDE THE THERMOSTAT LEVER ALL THE WAY LEFT TO THE COLD POSITION, FOR MAXIMUM COOLING (SLIDE LEVER LEFT OR RIGHT TO ADJUST DESIRED TEMPERATURE)

BLOWER SPEED
SLIDE LEVER UP TO DESIRED BLOWER SPEED, FROM OFF TO HI

MODE LEVER
SLIDE THE LEVER TO THE "DASH" POSITION

THERMOSTAT LEVER
IN A/C MODE SLIDE THE THERMOSTAT LEVER ALL THE WAY LEFT TO THE COLD POSITION TO ENGAGE COMPRESSOR, FOR MAXIMUM COOLING (SLIDE LEVER LEFT OR RIGHT TO ADJUST DESIRED TEMPERATURE)

HEAT MODE

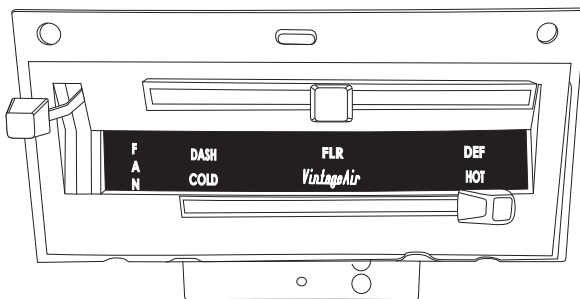

BLOWER SPEED
SLIDE LEVER UP TO DESIRED BLOWER SPEED, FROM OFF TO HI

MODE LEVER
SLIDE THE LEVER TO THE "FLR" POSITION

THERMOSTAT LEVER
IN HEAT MODE SLIDE THE THERMOSTAT LEVER ALL THE WAY RIGHT TO THE HOT POSITION, FOR MAXIMUM HEATING ((SLIDE LEVER LEFT OR RIGHT TO ADJUST DESIRED TEMPERATURE)

DEFROST/ DE-FOG MODE

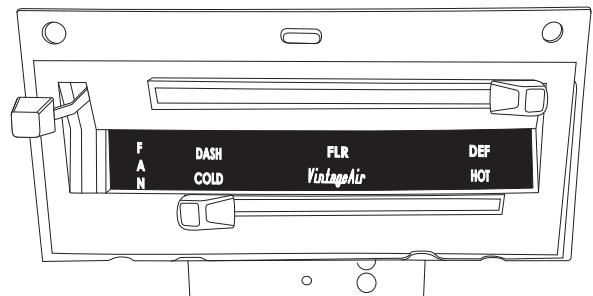

BLOWER SPEED
SLIDE LEVER UP TO DESIRED BLOWER SPEED, FROM OFF TO HI

MODE LEVER
SLIDE THE LEVER TO THE "DEF" POSITION

THERMOSTAT LEVER
IN DEF MODE SLIDE THE THERMOSTAT LEVER ALL THE WAY LEFT TO THE COLD POSITION TO ENGAGE COMPRESSOR. FOR MAXIMUM COOLING (SLIDE LEVER LEFT OR RIGHT TO ADJUST DESIRED TEMPERATURE)



1969-70 MUSTANG w/o AC CNTRL PNL

CONTROL KIT 474170

CONTROL KIT PACKING LIST

No.	QTY.	PART No.	DESCRIPTION	
1.	1	484075	69-70 MUSTANG CNTRL PNL MODE LABEL ASM	_____
2.	2	112002-SUA	SLIDE POT ASM	_____
3.	1	232006-VUR	GEN IV UNIVERSAL CONTROL HARNESS (TYPE B)	_____
4.	2	65976-VUE	3/16 PUSH-ON RING	_____
5.	2	491010-VUR	SLIDE POT CLAMP	_____
6.	5	21301-VUP	4 TIE WRAP	_____
7.	3	18247-VUB	#10 X 1/2 SHEET METAL SCREW	_____
8.	1	231520	GROUND WIRE	_____
9.	1	18058-VUB	5/16 NYLON CABLE CLAMP	_____
10.	1	246110-PUA	BLOWER SWITCH PC BOARD	_____

CHECKED BY: _____
 PACKED BY: _____
 DATE: _____

