

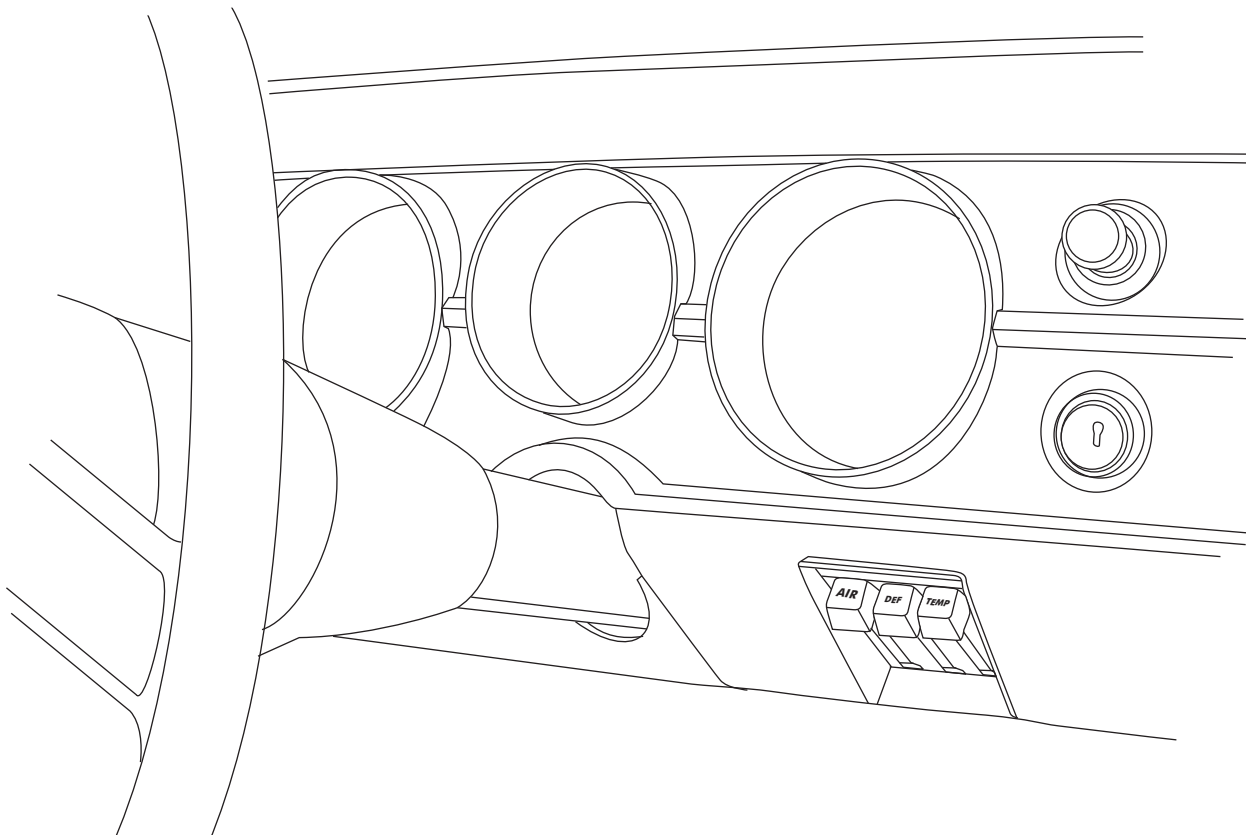


an ISO 9001: 2000 Registered Company

# 1964-65 CHEVELLE

WITHOUT AC CONTROL PANEL  
CONVERSION KIT

**473064**



18865 GOLL ST. - SAN ANTONIO, TX. - 78266 ph.210-654-7171 - fax 210-654-3113



## ***Table of Contents***

### PAGES

1. COVER
2. TABLE OF CONTENTS
3. PACKING LIST/ PARTS DISCLAIMER
4. REMOVING OEM CONTROL PANEL  
FIGURE 1
5. CABLE CONVERTER ASSEMBLY MODIFICATIONS & CABLE CONVERTER  
ASSEMBLY MOUNTING CLAMP INSTALLATION  
FIGURES 2 & 3
6. COLD/ HOT CABLE CONVERTER ASM INSTALLATION & CONTROL  
HARNESS  
FIGURES 4 & 5
7. CONTROL HARNESS CONT. & DASH/ FLR/ DEF CONVERTER ASM INSTALLATION  
FIGURES 6 & 7
8. CONTROL HARNESS & CONTROL HARNESS CONT.  
FIGURES 8 & 9
9. OFF/ HI CABLE CONVERTER ASM INSTALLATION & CONTROL HARNESS  
FIGURES 10 & 11
10. CONTROL HARNESS CONT. & CONTROL HARNESS FINAL STEP  
FIGURES 12 & 13
11. FINAL STEP & FINAL STEPS CONT.  
FIGURES 14 & 15
12. CONTROL PANEL CALIBRATION PROCEDURE
13. WIRING DIAGRAM
14. OPERATION OF CONTROLS
15. CONTROL PANEL KIT PACKING LIST

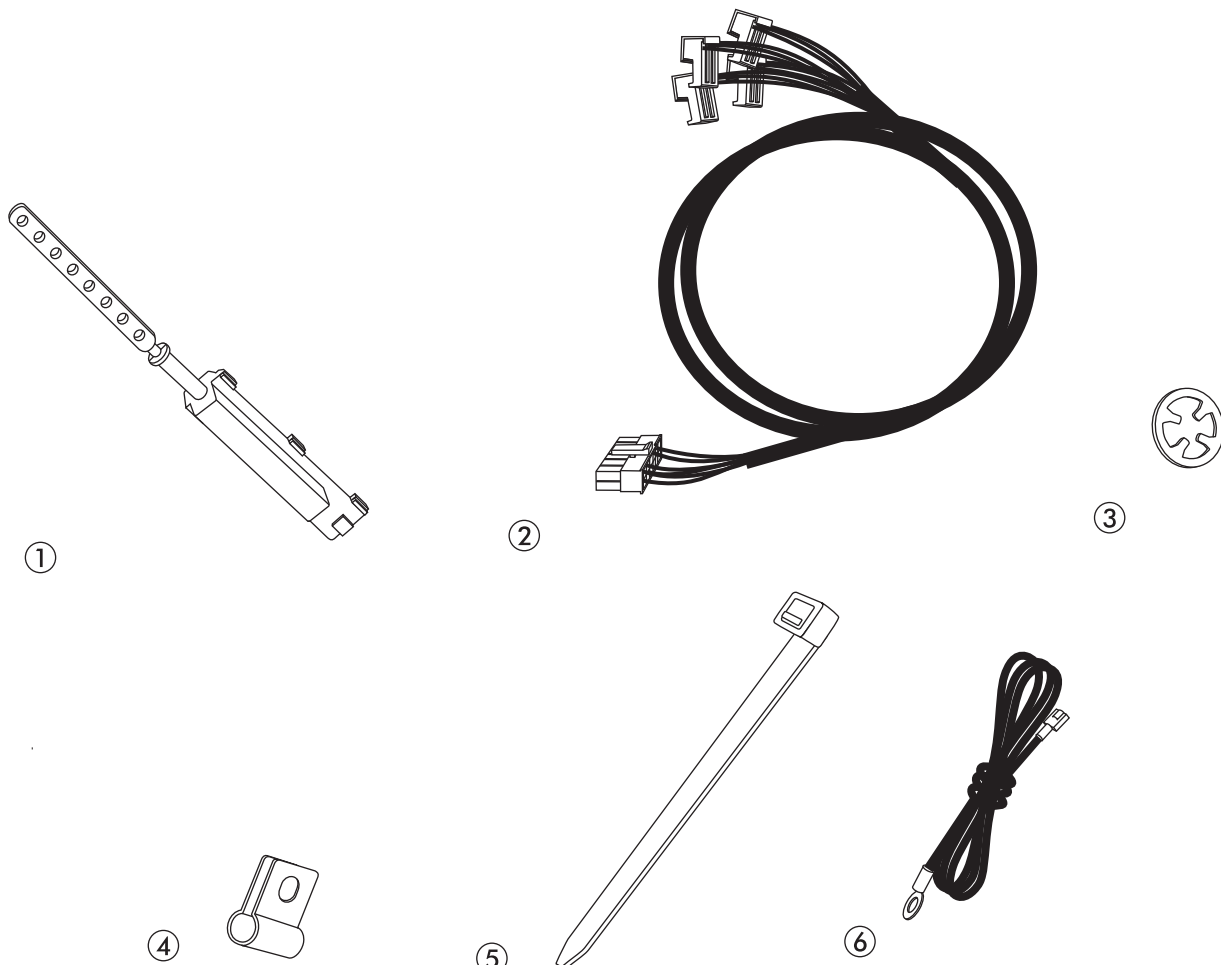


**CONTROL KIT PACKING LIST**

**CONTROL KIT  
473064**

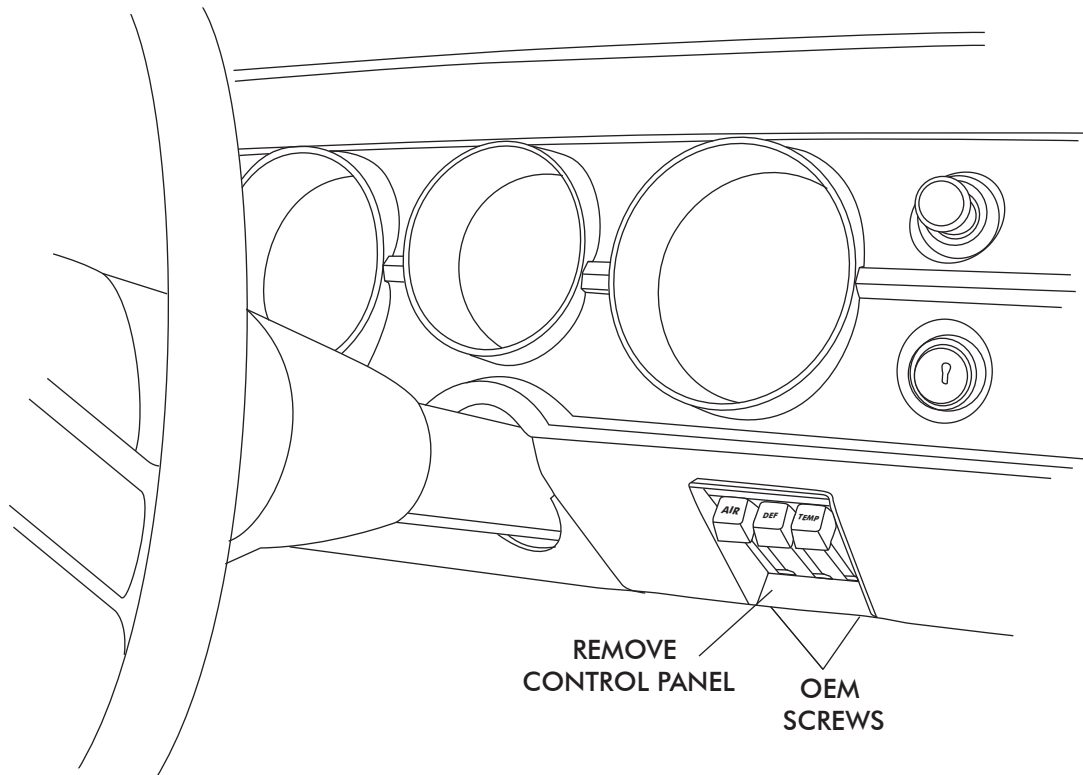
No.	QTY.	PART No.	DESCRIPTION
1.	3	112002-SUA	SLIDE POT ASM
2.	1	232006-VUR	GEN IV UNIVERSAL CONTROL HARNESS (TYPE B)
3.	3	65976-VUE	3/16" PUSH-ON RING
4.	3	491010-VUR	SLIDE POT CLAMP
5.	5	21301-VUP	4" TIE WRAP
6.	1	231520	GROUND WIRE

**\*\* BEFORE BEGINNING INSTALLATION OPEN ALL PACKAGES AND CHECK CONTENTS OF SHIPMENT. PLEASE REPORT ANY SHORTAGES DIRECTLY TO VINTAGE AIR WITHIN 15 DAYS. AFTER 15 DAYS, VINTAGE AIR WILL NOT BE RESPONSIBLE FOR MISSING OR DAMAGED ITEMS.**



**REMOVING OEM CONTROL PANEL**

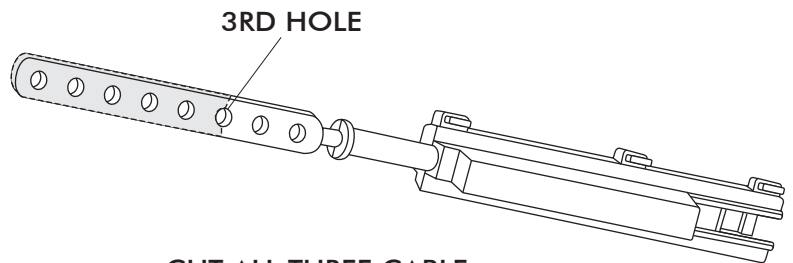
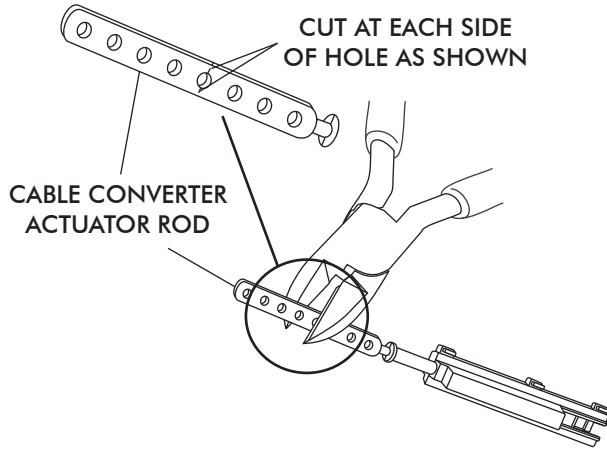
- REMOVE (4) OEM MOUNTING SCREWS FROM BOTTOM OF DASH (RETAIN SCREWS). SEE FIGURE 1 BELOW.
- DISCONNECT CABLES, WIRES FROM BACK OF CONTROL PANEL.
- REMOVE THE CONTROL PANEL.



**FIGURE 1**

**CABLE CONVERTER ASSEMBLY MODIFICATIONS**

- LOCATE THE (3) CABLE CONVERTER ASSEMBLIES, AND USING A PAIR OF WIRE CUTTERS, CUT CABLE CONVERTER ACTUATOR RODS AS SHOWN IN FIGURE 2 BELOW.

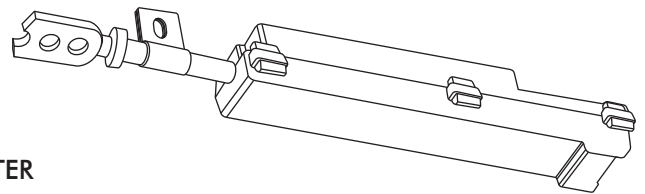
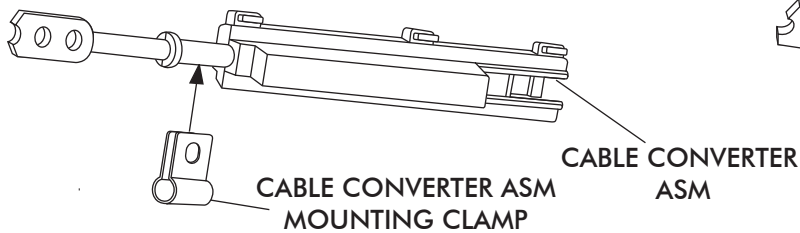


CUT ALL THREE CABLE CONVERTER ASSEMBLIES AT 3RD HOLE (REMOVE SHADED PORTION)

**FIGURE 2**

**CABLE CONVERTER ASSEMBLY MOUNTING CLAMP INSTALLATION**

- INSTALL CABLE CONVERTER ASM MOUNTING CLAMPS, SEE FIGURE 3 BELOW



ORIENT CLAMPS THE SAME DIRECTION FOR ALL (3) CABLE CONVERTER ASSEMBLIES

**FIGURE 3**

**ORIENT SLIDE POT ASSEMBLIES AS SHOWN AND INSTALL MOUNTING CLAMPS AS SHOWN. (NOTE: ORIENT CLAMPS IN RELATION TO THE (3) HOUSING SNAPS ON SLIDE POT ASSEMBLY)**



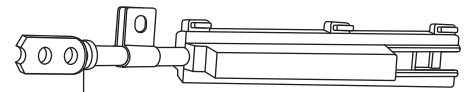
### CABLE CONVERTER ASSEMBLY INSTALLATION

#### COLD/ HOT CABLE CONVERTER ASSEMBLY

- INSTALL CABLE CONVERTER ASM ON THE COLD/ HOT LEVER. SEE FIGURE 4 BELOW.
- INSTALL CABLE CONVERTER LEVER PUSH ROD ONTO OEM CABLE MOUNTING STUD ON LEVER. SEE FIGURE 4 BELOW.
- SECURE THE CABLE CONVERTER ASM TO THE CONTROL PANEL USING THE OEM SCREW IN THE OEM CABLE CLAMP MOUNTING LOCATION. SEE FIGURE 4 BELOW.
- SINCE THE CABLE CONVERTER ASSEMBLY CAN SLIDE BACK AND FORTH IN CLAMP BEFORE SCREW IS TIGHTENED, POSITION CABLE CONVERTER ASSEMBLY SUCH THAT THE FLAT PART OF THE ROD IS AS CLOSE TO FLUSH AS POSSIBLE WITH THE END OF HOUSING AT THE LEVER'S INNER MOST POSITION. SEE FIGURE 4.
- SECURE CABLE CONVERTER LEVER PUSH ROD ONTO OEM CABLE MOUNTING STUD USING 3/16" PUSH-ON RING AS SHOWN IN FIGURE 4 BELOW.

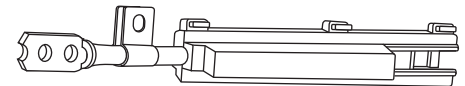


**FIGURE 4**



FLUSH

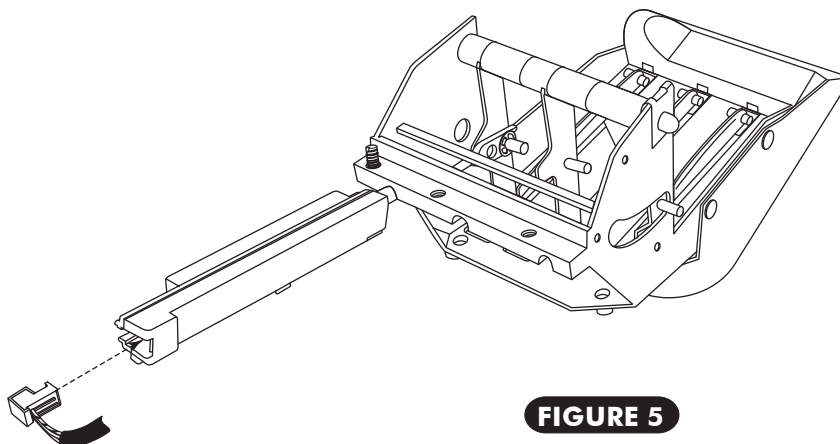
ROD SHOWN IN APPROX.  
INNER MOST POSITION



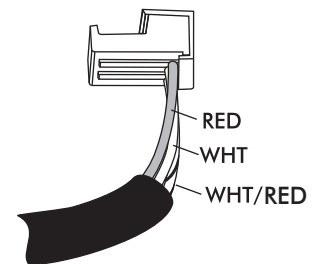
NOTE: DO NOT ALLOW ROD TO  
SEPARATE HOUSING WHEN  
ROD IS IN INNER MOST POSITION.

### CONTROL HARNESS

- LOCATE THE CONTROL PANEL WIRE HARNESS AND PLUG THE CORRESPONDING WIRES INTO THE CORRECT CABLE CONVERTER ASSEMBLY AS SHOWN IN FIGURE 5 BELOW.



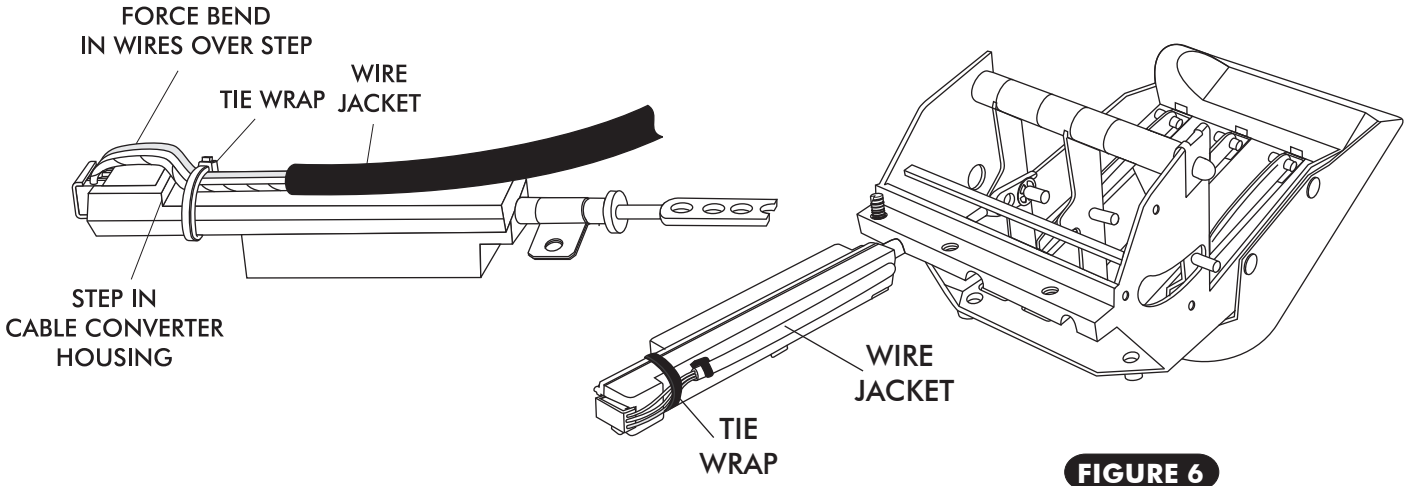
**FIGURE 5**



**COLD/ HOT  
CABLE CONVERTER  
ASSEMBLY**

**CONTROL HARNESS CONT.**

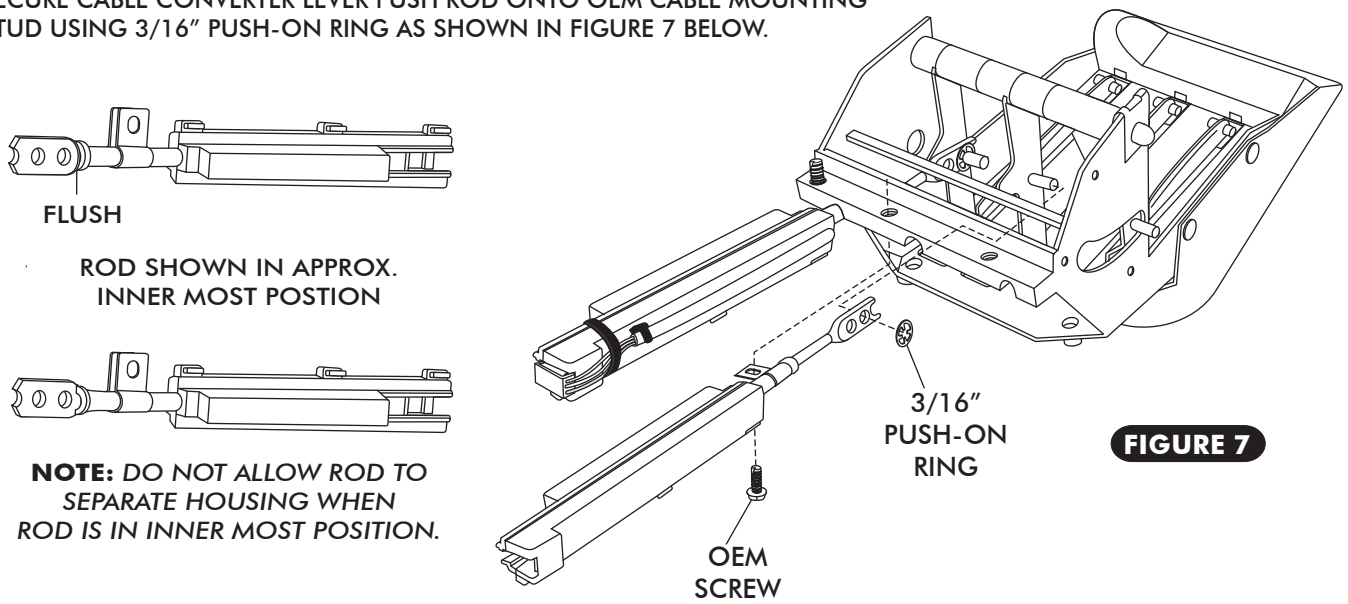
- ONCE WIRES ARE CORRECTLY PLUGGED INTO CABLE CONVERTER ASSEMBLY, SECURE WIRES TO THE CABLE CONVERTER ASSEMBLY USING TIE WRAPS (SUPPLIED). SEE FIGURE 6 BELOW. THE TIE WRAP MUST BE LOCATED BETWEEN THE END OF THE WIRE JACKET AND THE STEP IN THE CABLE CONVERTER HOUSING FORCING A BEND IN EACH WIRE AS THEY PASS OVER THE STEP IN THE CABLE CONVERTER HOUSING. HEAD OF TIE WRAP MUST FALL ON EDGE OF HOUSING AS SHOWN TO REMAIN TIGHT. ENSURE THAT THE TIE WRAPS ARE SNUG ENOUGH THAT THE WIRES CANNOT MOVE. SEE FIGURE 6.



**FIGURE 6**

**DASH/ FLR/ DEF CABLE CONVERTER ASSEMBLY**

- INSTALL CABLE CONVERTER ASM ON THE DASH/ FLR/ DEF LEVER. SEE FIGURE 7 BELOW.
- INSTALL CABLE CONVERTER LEVER PUSH ROD ONTO OEM CABLE MOUNTING STUD ON LEVER. SEE FIGURE 7 BELOW.
- SECURE THE CABLE CONVERTER ASM TO THE CONTROL PANEL USING OEM SCREW IN THE OEM CABLE CLAMP MOUNTING LOCATION, SEE FIGURE 7 BELOW.
- SINCE THE CABLE CONVERTER ASSEMBLY CAN SLIDE BACK AND FORTH IN CLAMP BEFORE SCREW IS TIGHTENED, POSITION CABLE CONVERTER ASSEMBLY SUCH THAT THE FLAT PART OF THE ROD IS AS CLOSE TO FLUSH AS POSSIBLE WITH THE END OF HOUSING AT THE LEVER'S INNER MOST POSITION. SEE FIGURE 7.
- SECURE CABLE CONVERTER LEVER PUSH ROD ONTO OEM CABLE MOUNTING STUD USING 3/16" PUSH-ON RING AS SHOWN IN FIGURE 7 BELOW.

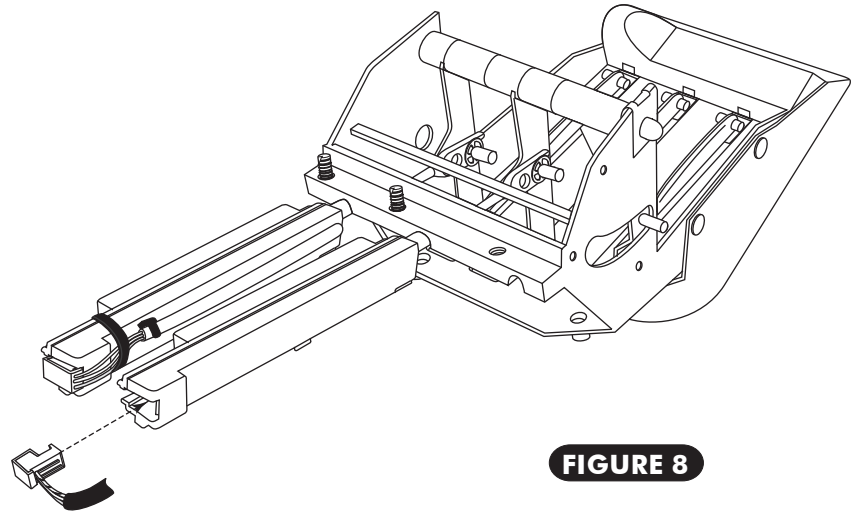
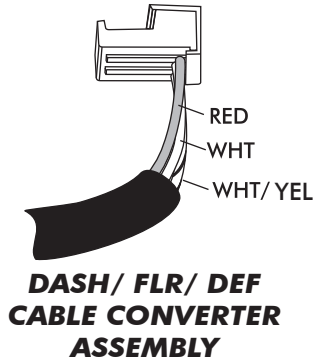


**FIGURE 7**



### CONTROL HARNESS

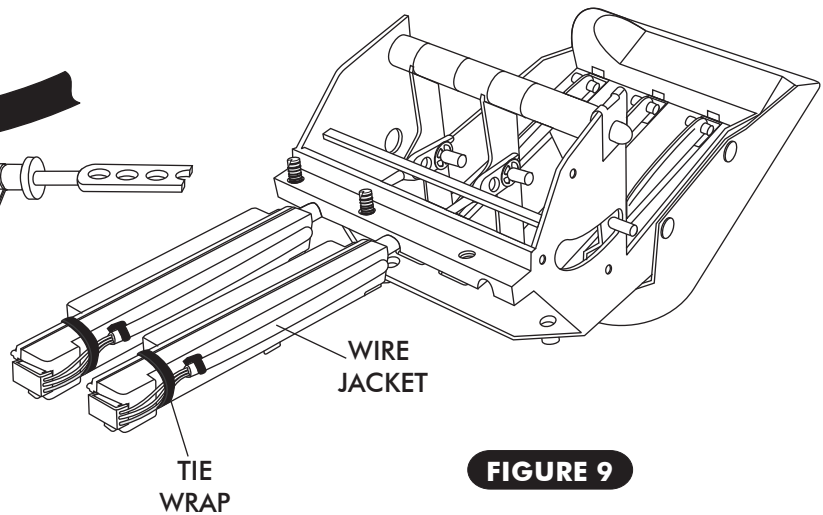
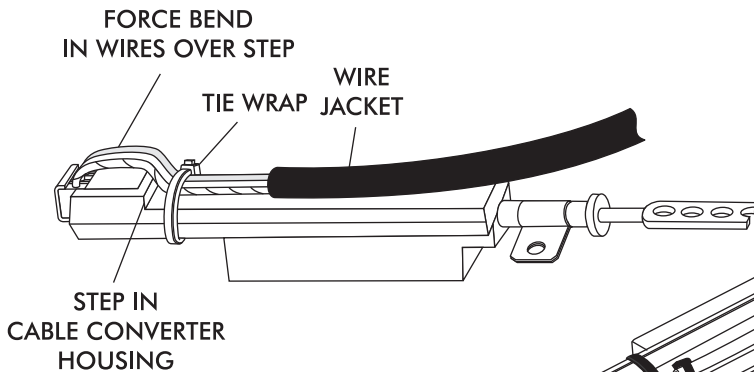
- LOCATE THE CONTROL PANEL WIRE HARNESS AND PLUG THE CORRESPONDING WIRES INTO THE CORRECT CABLE CONVERTER ASSEMBLY AS SHOWN IN FIGURE 8 BELOW.



**FIGURE 8**

### CONTROL HARNESS CONT.

- ONCE WIRES ARE CORRECTLY PLUGGED INTO CABLE CONVERTER ASSEMBLY, SECURE WIRES TO THE CABLE CONVERTER ASSEMBLY USING TIE WRAPS (SUPPLIED). SEE FIGURE 9 BELOW. THE TIE WRAP MUST BE LOCATED BETWEEN THE END OF THE WIRE JACKET AND THE STEP IN THE CABLE CONVERTER HOUSING FORCING A BEND IN EACH WIRE AS THEY PASS OVER THE STEP IN THE SLIDE POT HOUSING. HEAD OF TIE WRAP MUST FALL ON EDGE OF HOUSING AS SHOWN TO REMAIN TIGHT. ENSURE THAT THE TIE WRAPS ARE SNUG ENOUGH THAT THE WIRES CANNOT MOVE. SEE FIGURE 9.

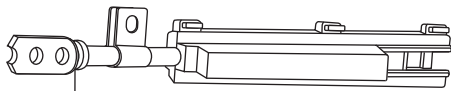


**FIGURE 9**

**CABLE CONVERTER ASSEMBLY INSTALLATION**

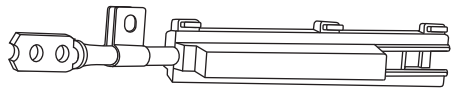
**OFF/ HI CABLE CONVERTER ASSEMBLY**

- INSTALL CABLE CONVERTER ASM ON THE OFF/ HI LEVER. SEE FIGURE 10 BELOW
- INSTALL CABLE CONVERTER LEVER PUSH ROD ONTO OEM CABLE MOUNTING STUD ON LEVER. SEE FIGURE 10 BELOW.
- SECURE THE CABLE CONVERTER ASM TO THE CONTROL PANEL USING THE OEM SCREW IN THE OEM CABLE CLAMP MOUNTING LOCATION. SEE FIGURE 10 BELOW.
- SINCE THE CABLE CONVERTER ASSEMBLY CAN SLIDE BACK AND FORTH IN CLAMP BEFORE SCREW IS TIGHTENED, POSITION CABLE CONVERTER ASSEMBLY SUCH THAT THE FLAT PART OF THE ROD IS AS CLOSE TO FLUSH AS POSSIBLE WITH THE END OF HOUSING AT THE LEVER'S INNER MOST POSITION. SEE FIGURE 10.
- SECURE CABLE CONVERTER LEVER PUSH ROD ONTO OEM CABLE MOUNTING STUD USING 3/16" PUSH-ON RING AS SHOWN IN FIGURE 10 BELOW.

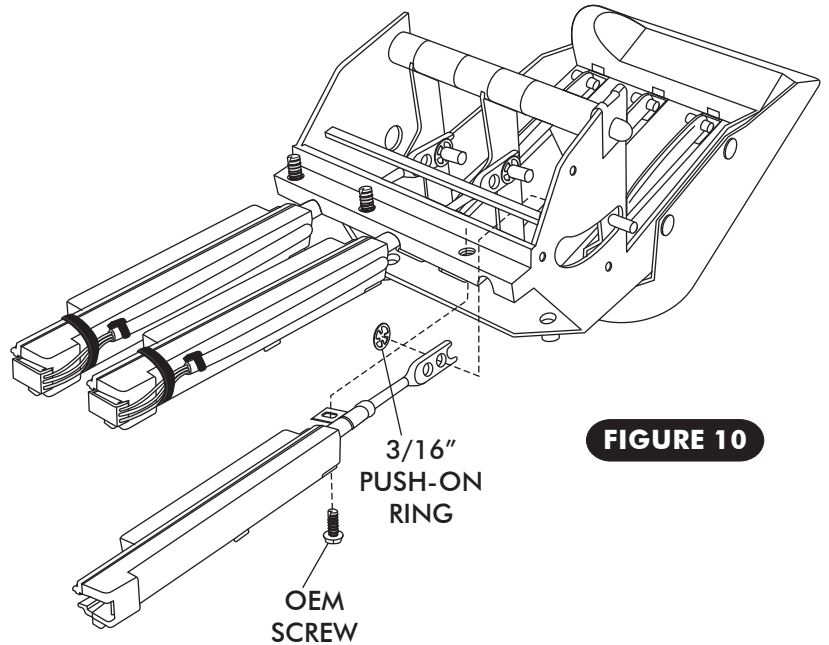


FLUSH

ROD SHOWN IN APPROX. INNER MOST POSITION



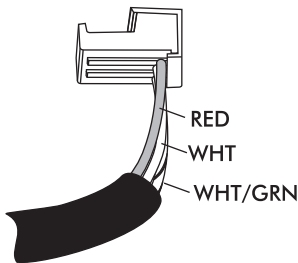
NOTE: DO NOT ALLOW ROD TO SEPARATE HOUSING WHEN ROD IS IN INNER MOST POSITION.



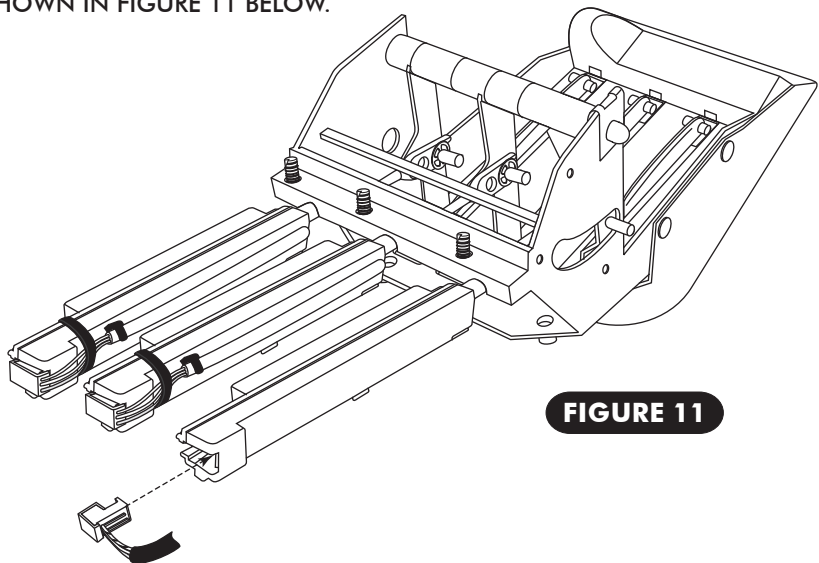
**FIGURE 10**

**CONTROL HARNESS**

- LOCATE THE CONTROL PANEL WIRE HARNESS AND PLUG THE CORRESPONDING WIRES INTO THE CORRECT CABLE CONVERTER ASSEMBLY AS SHOWN IN FIGURE 11 BELOW.



**OFF/ HI CABLE CONVERTER ASSEMBLY**

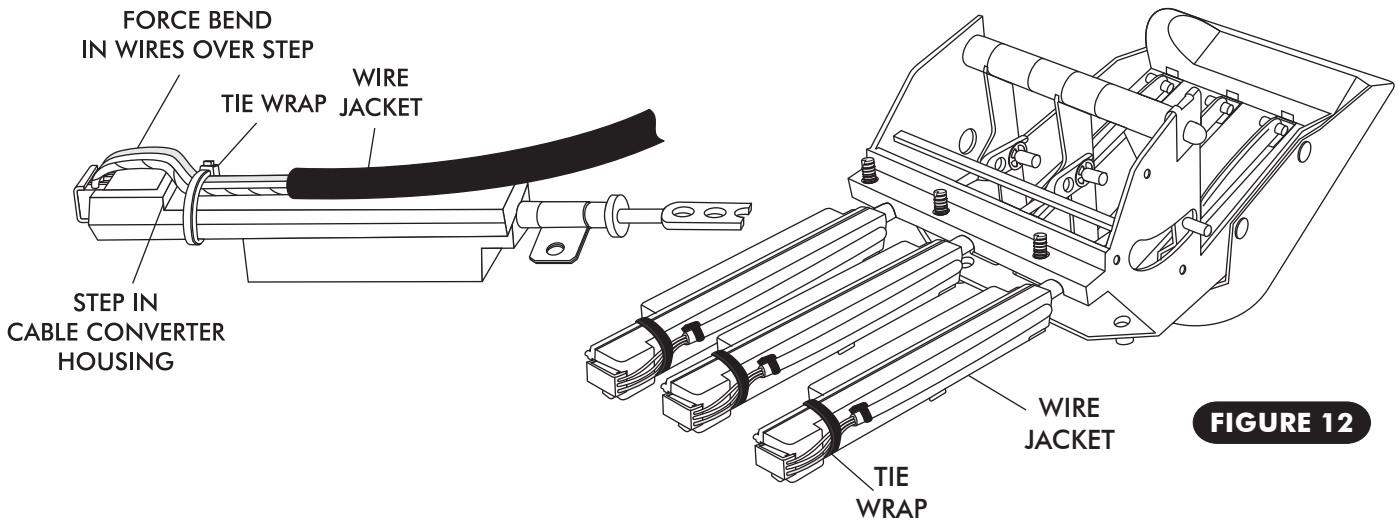


**FIGURE 11**



### CONTROL HARNESS CONT.

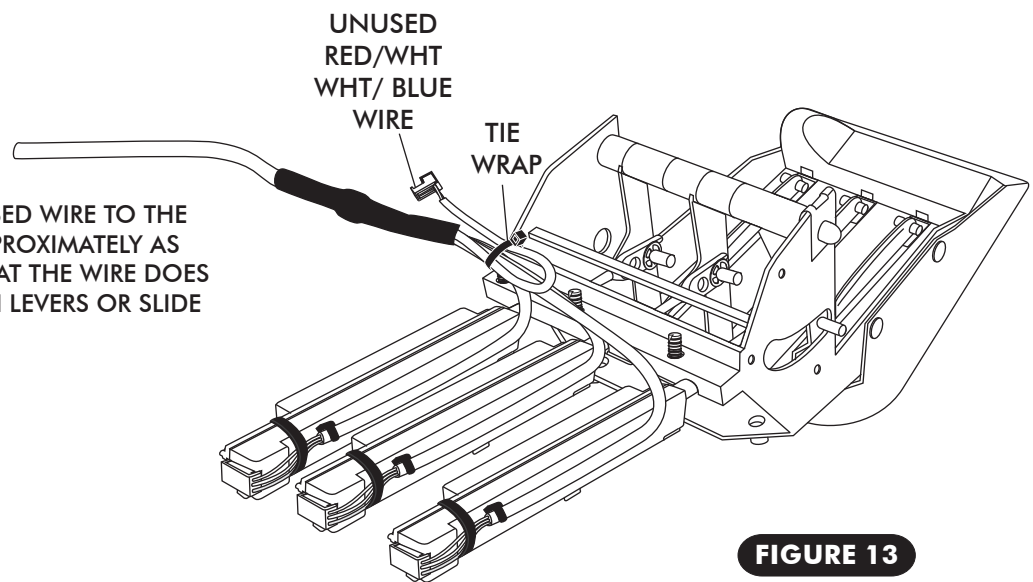
- ONCE WIRES ARE CORRECTLY PLUGGED INTO CABLE CONVERTER ASSEMBLY, SECURE WIRES TO THE CABLE CONVERTER ASSEMBLY USING TIE WRAPS (SUPPLIED). SEE FIGURE 12 BELOW. THE TIE WRAP MUST BE LOCATED BETWEEN THE END OF THE WIRE JACKET AND THE STEP IN THE CABLE CONVERTER HOUSING FORCING A BEND IN EACH WIRE AS THEY PASS OVER THE STEP IN THE SLIDE POT HOUSING. HEAD OF TIE WRAP MUST FALL ON EDGE OF HOUSING AS SHOWN TO REMAIN TIGHT. ENSURE THAT THE TIE WRAPS ARE SNUG ENOUGH THAT THE WIRES CANNOT MOVE. SEE FIGURE 12.



### CONTROL HARNESS FINAL STEP

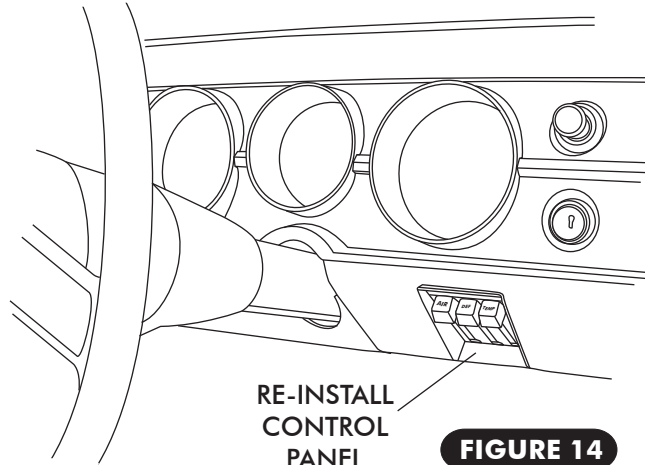
- USING THE SUPPLIED TIE-WRAPPS, TIE THE WIRES TO THE CONTROL PANEL AS SHOWN IN FIGURE 13. BELOW CONFIRM THAT WIRES ARE SECURED AND DO NOT INTERFERE WITH LEVER OPERATION OR CABLE CONVERTER ASSEMBLY.

**NOTE:** TIE THE UNUSED WIRE TO THE CONTROL PANEL APPROXIMATELY AS SHOWN, ENSURE THAT THE WIRE DOES NOT INTERFERE WITH LEVERS OR SLIDE POT ASSEMBLES.



**FINAL STEPS**

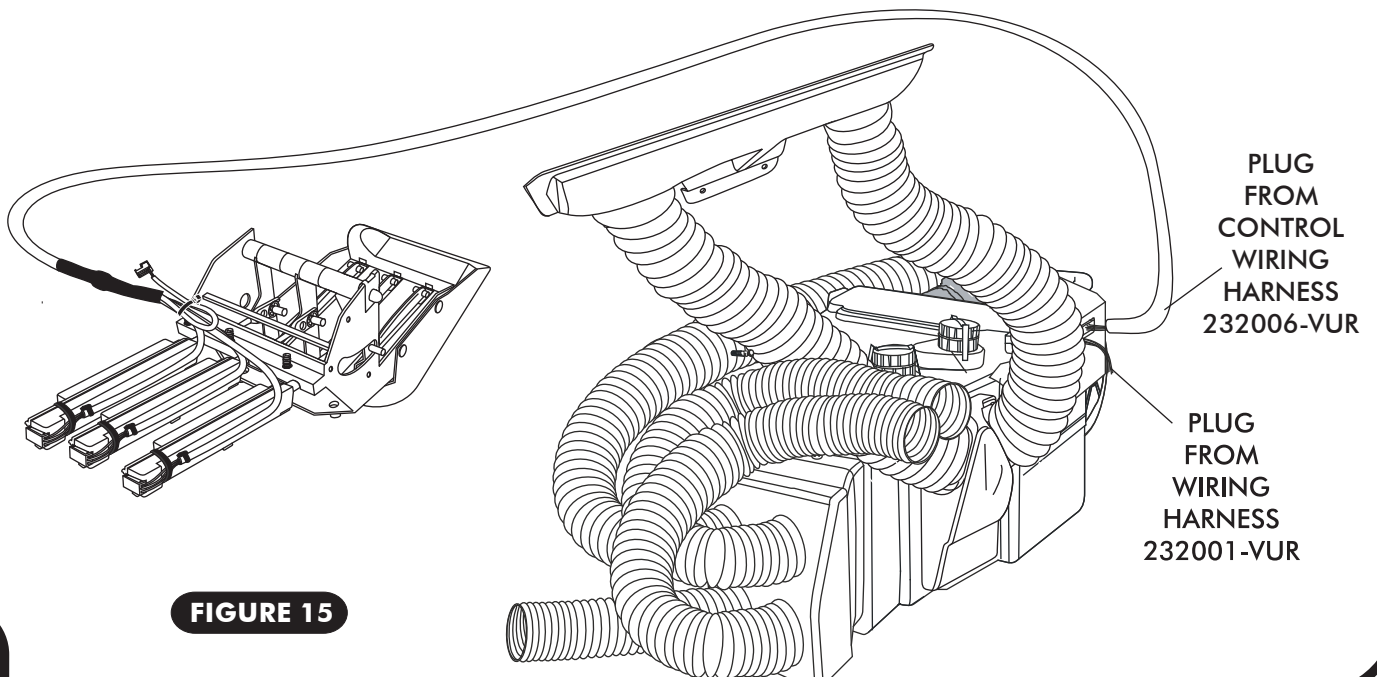
- RE-INSTALL CONTROL PANEL IN DASH USING THE (4) OEM SCREWS.



**FIGURE 14**

**FINAL STEPS CONT.**

- PLUG THE WIRING HARNESS INTO THE ECU MODULE ON SUB CASE. SEE FIGURE 15 BELOW.
  - WIRE ACCORDING TO WIRING DIAGRAM ON PAGE 13.
  - CONTROL PANEL CALIBRATION PROCEDURE AND OPERATION INSTRUCTIONS:
    - CALIBRATING THE CONTROL PANEL WILL SET THE RANGE OF TRAVEL FOR THE CABLE CONVERTERS CONNECTED TO THE OEM CONTROL PANEL LEVERS. PERFORMING THIS PROCEDURE WILL SET THE LIMITS OF THE CABLE CONVERTERS AT THEIR HIGHEST AND LOWEST POINTS.
    - LOCATE THE GRAY WIRE WITH AN UNUSED CONNECTOR IN THE WIRING HARNESS NEAR THE TWO CABLE HARNESS RELAYS. THE WIRE IS LABELED PRGM ON THE WIRING DIAGRAM ON PAGE 13.
    - IT WILL BE NECESSARY TO GROUND THE GRAY WIRE FOR APPROXIMATELY FIVE SECONDS WHILE MOVING THE CONTROLS SO IT IS SOMETIMES HELPFUL TO ATTACH ONE END OF THE WHITE JUMPER WIRE TO THE VEHICLE'S GROUND (FOR EXAMPLE THE CHASSIS) AND HAVE THE OTHER END READY TO CONNECT TO THE GRAY PRGM WIRE WHEN THE PROCEDURE REQUIRES IT.
- TO CALIBRATE THE CONTROL PANEL FOLLOW THE CALIBRATION PROCEDURES ON PAGE 12.

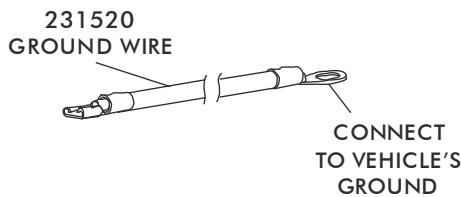


**FIGURE 15**

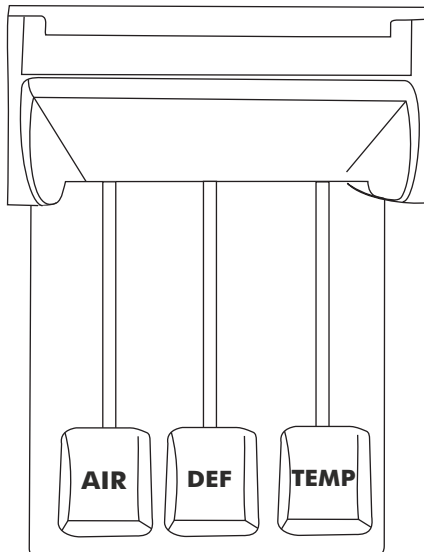


### CONTROL PANEL CALIBRATION PROCEDURE

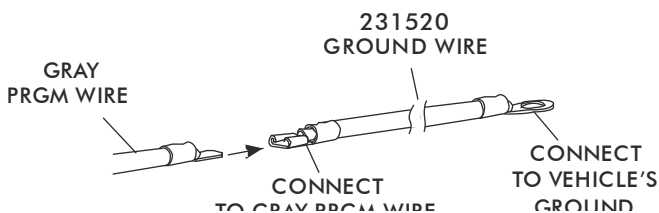
1. TURN THE IGNITION SWITCH ON (DO NOT START THE ENGINE)
2. CONNECT THE WHITE JUMPER WIRE TO VEHICLE'S GROUND (FOR EXAMPLE THE VEHICLE CHASSIS). ENSURE THAT THE GRAY WIRE IS NOT GROUNDED . DO NOT CONNECT JUMPER WIRE TO THE GRAY PRGM WIRE.



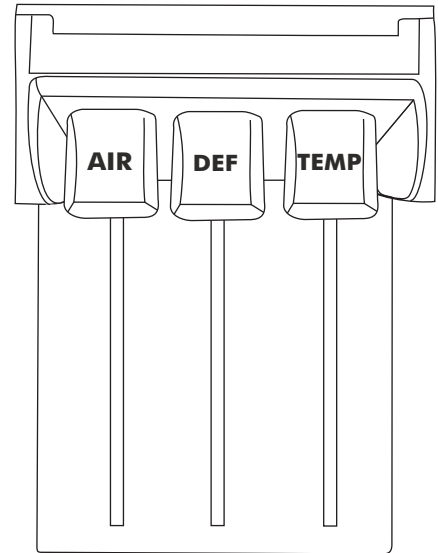
3. MOVE ALL OF THE CONTROL LEVERS TO THEIR MAXIMUM POSITIONS, AS SHOWN.



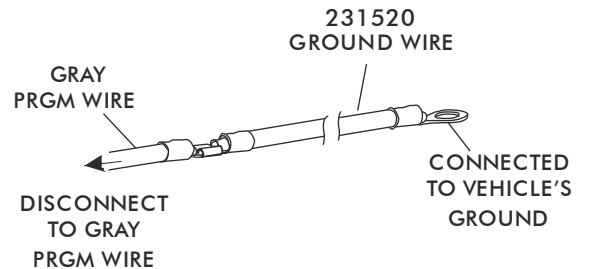
4. GROUND THE GRAY WIRE BY CONNECTING THE GRAY PRGM WIRE & WHITE JUMPER WIRE FOR APPROXIMATELY 5 SECONDS (THE BLOWER WILL CHANGE SPEEDS WHEN STEP FOUR IS COMPLETE)



5. LEAVING THE GRAY WIRE GROUNDED, MOVE ALL OF THE CONTROL LEVERS TO THEIR MINIMUM POSITIONS AS SHOWN.



6. DISCONNECT THE GRAY WIRE FROM THE WHITE GROUND JUMPER WIRE (THE BLOWER WILL CHANGE SPEEDS WHEN STEP SIX IS COMPLETE)



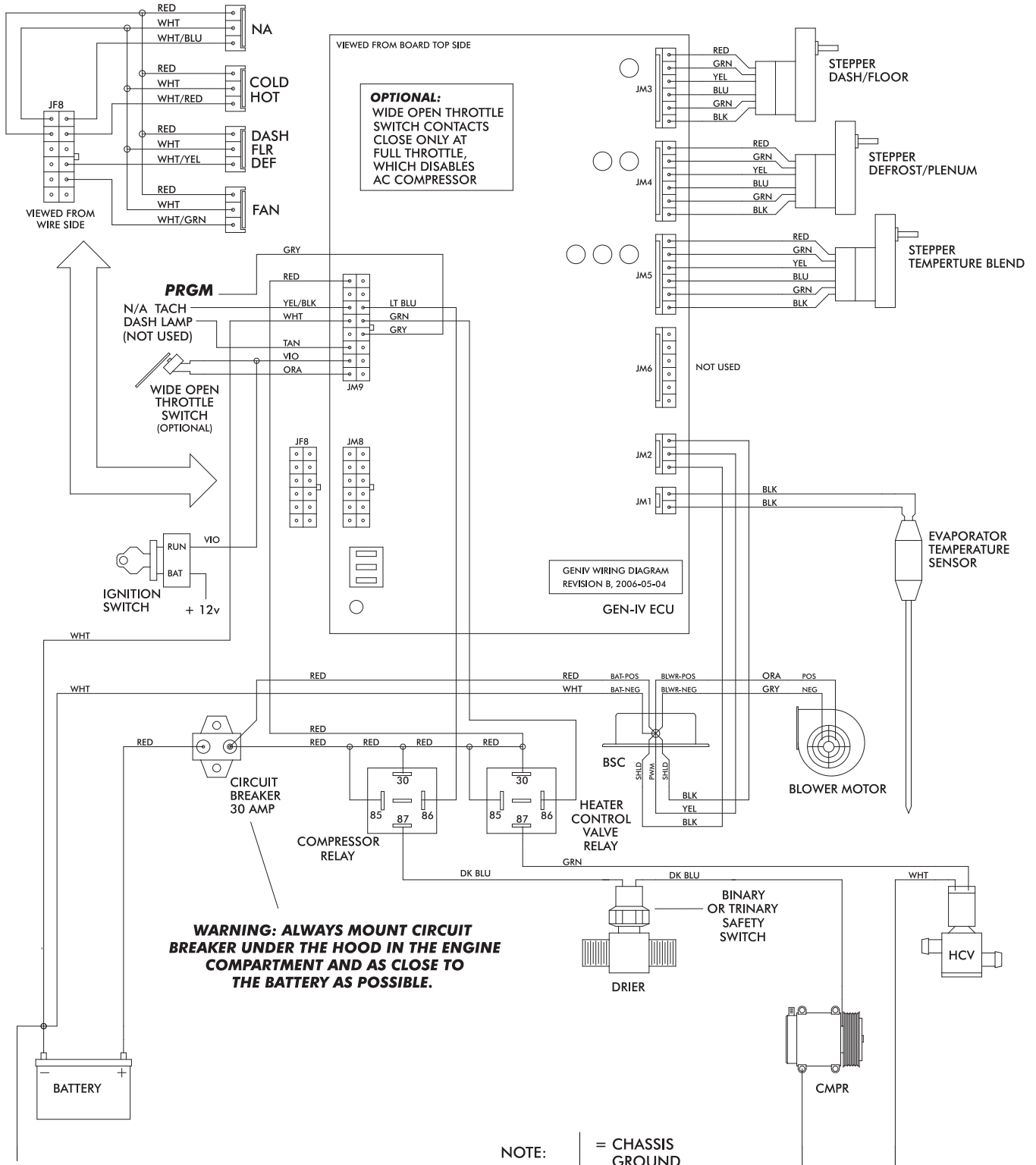
7. START THE ENGINE AND TEST ALL OF THE CONTROLS TO ENSURE THAT THE INTENDED RESULTS WERE ACCOMPLISHED.
8. DISCONNECT THE WHITE JUMPER WIRE FROM VEHICLE'S GROUND.

NOTE: THIS PROCEDURE MAY BE REPEATED IF NECESSARY.

**\* WHEN FINISHED, TAPE OVER PROGRAM WIRE CONNECTOR WITH ELECTRICAL TAPE TO PREVENT ACCIDENTAL CONTACT WITH CHASSIS GROUND.**



**WIRING DIAGRAM**





## OPERATION OF CONTROLS

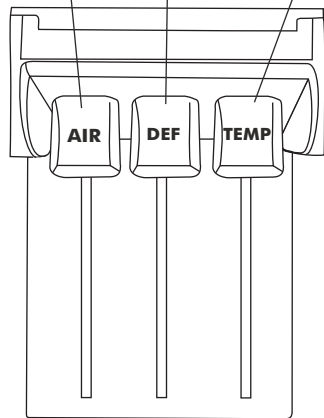
**NOTE: CONTROLS MUST BE CALIBRATED PRIOR TO FIRST OPERATION- REFER TO CONTROL PANEL INSTRUCTIONS**

**BLOWER SPEED      MODE LEVER      THERMOSTAT LEVER**

**BLOWER SPEED**  
THIS LEVER CONTROLS THE BLOWER SPEED, FROM OFF TO HI

**MODE LEVER**  
THIS LEVER CONTROLS THE MODE POSITIONS FROM DASH TO FLOOR TO DEFROST

**THERMOSTAT LEVER**  
THIS LEVER CONTROLS THE TEMPERATURE FROM HOT TO COLD

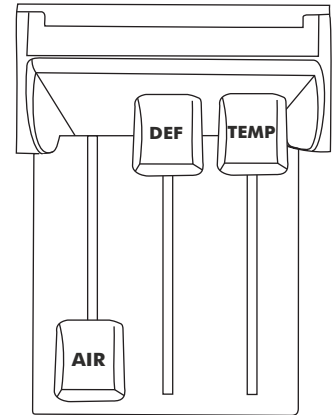


**SYSTEM OFF**

**BLOWER SPEED**  
SLIDE THE FAN LEVER UP OR DOWN TO SELECT DESIRE FAN SPEED (SLIDE LEVER ALL THE WAY DOWN FOR MAXIMUM FAN SPEED)

**MODE LEVER**  
SLIDE THE MODE LEVER ALL THE WAY UP FOR DASH MODE

**THERMOSTAT LEVER**  
IN A/C MODE SLIDE THE TEMP LEVER ALL THE WAY UP TO ENGAGE COMPRESSOR FOR MAXIMUM COOLING. (SLIDE LEVER UP OR DOWN TO ADJUST DESIRED TEMPERATURE)

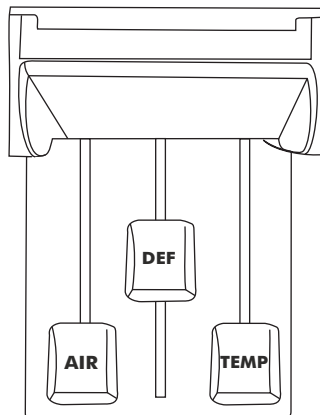


**A/C MODE**

**BLOWER SPEED**  
SLIDE THE FAN LEVER UP OR DOWN TO SELECT DESIRE FAN SPEED (SLIDE LEVER ALL THE WAY DOWN FOR MAXIMUM FAN SPEED)

**MODE LEVER**  
SLIDE THE MODE LEVER TO THE CENTER FOR FLOOR MODE (SLIDE LEVER UP OR DOWN TO BLEND BETWEEN DESIRED MODE POSITIONS)

**THERMOSTAT LEVER**  
IN HEAT MODE SLIDE THE TEMP LEVER ALL THE WAY DOWN FOR MAXIMUM HEATING. (SLIDE LEVER UP OR DOWN TO ADJUST DESIRED TEMPERATURE)

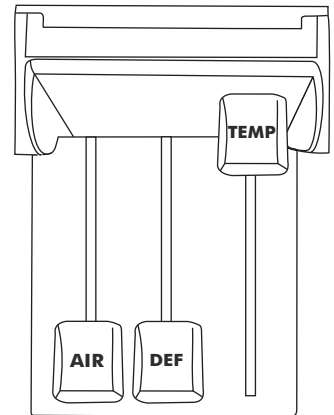


**HEAT MODE**

**BLOWER SPEED**  
SLIDE THE FAN LEVER UP OR DOWN TO SELECT DESIRE FAN SPEED (SLIDE LEVER ALL THE WAY DOWN FOR MAXIMUM FAN SPEED)

**MODE LEVER**  
SLIDE THE MODE LEVER ALL THE WAY DOWN FOR DEFROST MODE (SLIDE LEVER UP OR DOWN TO BLEND BETWEEN DESIRED MODE POSITIONS)

**THERMOSTAT LEVER**  
IN DEF MODE SLIDE THE TEMP LEVER ALL THE WAY UP TO ENGAGE COMPRESSOR FOR MAXIMUM COOLING. (SLIDE LEVER UP OR DOWN TO ADJUST DESIRED TEMPERATURE)



**DEFROST MODE**



**CONTROL KIT PACKING LIST**

**CONTROL KIT  
473064**

No.	QTY.	PART No.	DESCRIPTION
1.	3	112002-SUA	SLIDE POT ASM
2.	1	232006-VUR	GEN IV UNIVERSAL CONTROL HARNESS (TYPE B)
3.	3	65976-VUE	3/16" PUSH-ON RING
4.	3	491010-VUR	SLIDE POT CLAMP
5.	5	21301-VUP	4" TIE WRAP
6.	1	231520	GROUND WIRE

**\*\* BEFORE BEGINNING INSTALLATION OPEN ALL PACKAGES AND CHECK CONTENTS OF SHIPMENT. PLEASE REPORT ANY SHORTAGES DIRECTLY TO VINTAGE AIR WITHIN 15 DAYS. AFTER 15 DAYS, VINTAGE AIR WILL NOT BE RESPONSIBLE FOR MISSING OR DAMAGED ITEMS.**

