

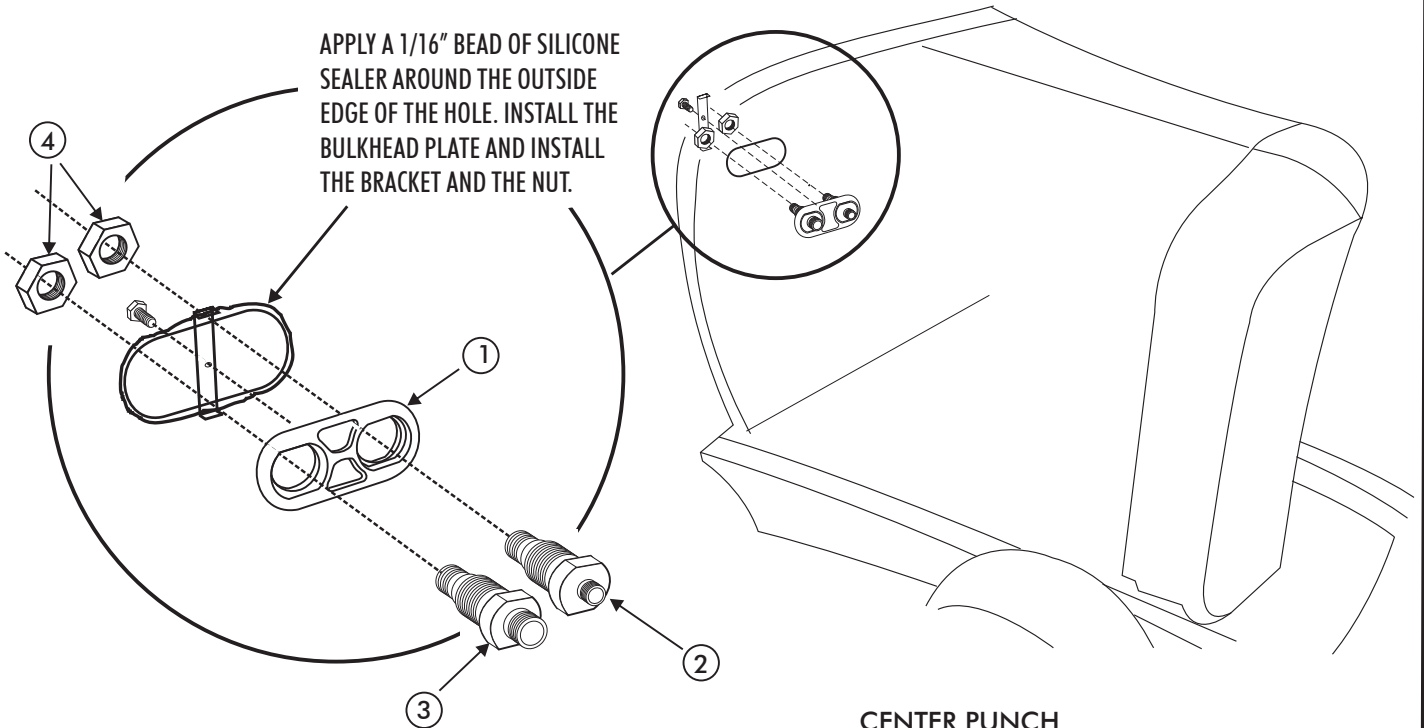

## 2-WAY BULKHEAD

### 34215-VUQ 2-WAY BULKHEAD #6 & #10

APPLY A 1/16" BEAD OF SILICONE SEALER AROUND THE OUTSIDE EDGE OF THE HOLE. INSTALL THE BULKHEAD PLATE AND INSTALL THE BRACKET AND THE NUT.



MAKE CIRCULAR ENDS OF OPENING WITH 1-1/4" HOLE SAW. CENTER PUNCH PILOT HOLE BETWEEN CENTERS AS SHOWN. WHEN HOLES ARE CUT, SNIP REMAINING BRIDGE FOR FINAL OPENING. OPENING SHOULD MATCH PATTERN AS SHOWN.

CUT THE TEMPLATE ON THE DOTTED LINES AND TAPE IN POSITION. TRACE AROUND THE TEMPLATE AND CUT OUT THE AREA.

**DO NOT EXCEED THE DIMENSIONS GIVEN.**

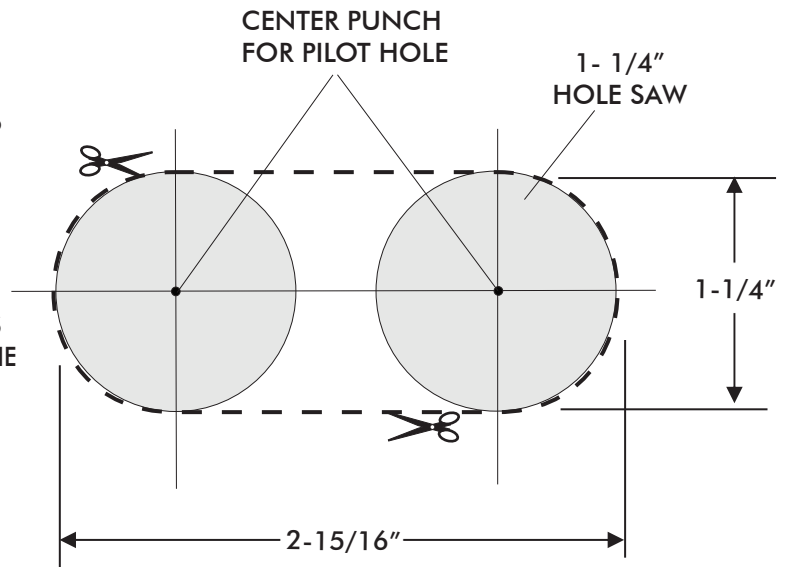

### 2-WAY BULKHEAD #6 & #10

34215-VUQ

No.	QTY.	PART NO.	DESCRIPTION	CHECK LIST
1.	1	34002-VUQ	BULKHEAD PLATE	_____
2.	1	35331-VUQ	#6 A/C BULKHEAD FITTING	_____
3.	1	35333-VUQ	#10 A/C BULKHEAD FITTING	_____
4.	2	186078-NMR	#10 BULKHEAD FITTING NUT	_____

CHECKED BY: \_\_\_\_\_  
 PACKED BY: \_\_\_\_\_  
 DATE: \_\_\_\_\_