



GEN II



Patents Pending

For Upgrade ProLine Controls See Pages 24

66005 Series - GEN-II Mini - Specify Heat & Cool or Heat, Cool & Defrost model.

GEN-II TECHNOLOGY FOR THE SMALLEST CARS AND TRUCKS! State of the art GEN-II servo motor control technology is now incorporated into our smallest heat & cool system. All new CAD designed case allows more capacity and air flow than our original Compac systems. The ideal system for trucks and smaller hot rods. Features true bi-level operation in cool and heat modes and a more powerful dedicated dehumidified defroster mode.

GEN-II Technology Benefits:

- High torque screw-drive servo motors control all butterfly airflow doors.**
Increased travel on these doors allows much greater airflow.
Immediate response to control input and superior door sealing .
No reliance on engine vacuum (important with high performance engines!).
- Re-engineered heating/cooling coil.**
Increases cooling capacity by over 20%, and heating capacity by over 100%!
- Re-engineered and computer aided design of evaporator case.**
Optimized internal case design allows significant airflow volume increases.
Increased capacity and control of dehumidified defroster airflow.
Defrost mode features our exclusive dedicated airflow.
Blower fan motor isolated on rubber mounts for quiet running and longer life.

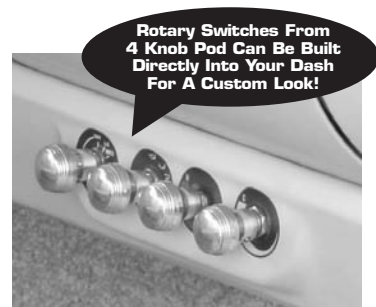

Rotary Switches From 4 Knob Pod Can Be Built Directly Into Your Dash For A Custom Look!

New! - Ask your local dealer to loan you a Gen-II Mock-Up Unit.

Light weight empty-case units will aid you in fitting a Gen-II system in your car. See next page.

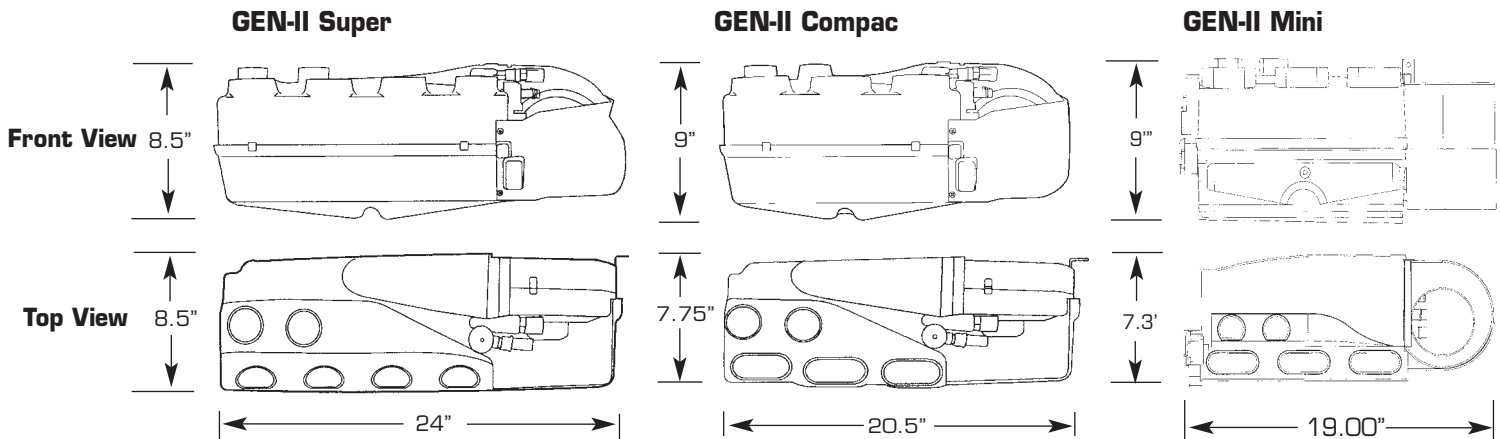

MANAGEMENT TEAM

George Packard is our National Sales Manager. After implementing many successful manufacturing standards as Production Manager we have now called on George to guide our sales team. With over 13 years at Vintage Air and managing a major street rod building business, he is uniquely qualified to aid our dealer network in satisfying each customer's needs. In his spare time, George drives his show quality, owner built, red '32 five window.