

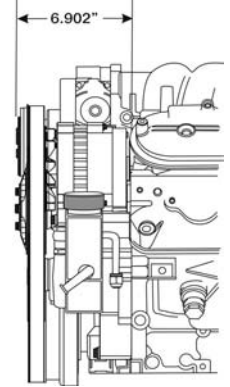

**LS CHEVY
FRONT RUNNER™ ENGINE DRIVE SYSTEM**

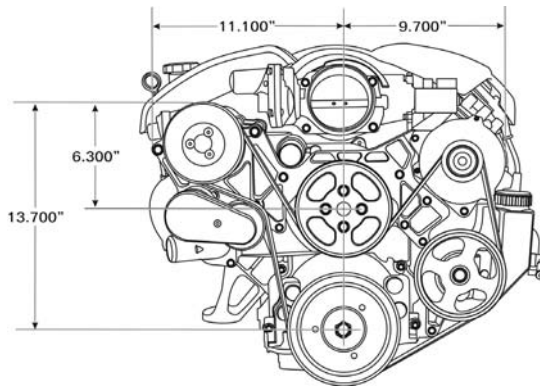

MEASUREMENTS ARE FROM FACE OF BLOCK

LS Chevy Front Runner™ Drive System Includes:

- Main Truss Mounting Bracket
- ATI Harmonic Balancer
- Power Steering Pump Bracket
- Hi-Perf Aluminum Water Pump
- ARP Polished Stainless Hardware
- Sanden SD7 Compressor With Formed Aluminum Hardlines
- 140 Amp Alternator
- Compressor Clutch Cover
- Tensioner Cover
- Crankshaft Pulley
- Water Pump Pulley
- Power Steering Pump Pulley (With Power Steering Kit)
- Dayco Perf Serpentine Drive Belt
- Dayco OEM Tensioner
- Delphi-Saginaw Power Steering Pump With Integral Reservoir



Bright LS Chevy Front Runner™ Drive System

- 174014 With Power Steering (includes Pump)
- 174016 With Power Steering (less Power Steering Pump)
- 175015 Non-Power Steering

Black Hardcoat LS Chevy Front Runner™ Drive System

- 174011 With Power Steering (Includes Pump)
- 174017 With Power Steering (Less Power Steering Pump)
- 175011 Non-Power Steering

**Hardcoat kits include black hardcoated pulleys and black anodized bracket, clutch & tensioner covers*

Bright LS7 Chevy Front Runner™ Drive System

- 174012 With Power Steering (Includes Pump)
- 174019 With Power Steering (Less Power Steering Pump)
- 175012 Non-Power Steering

Black Hardcoat LS7 Chevy Front Runner™ Drive System

- 174013 With Power Steering (Includes Pump)
- 174018 With Power Steering (Less Power Steering Pump)
- 175013 Non-Power Steering

**Hardcoat kits include black hardcoated pulleys and black anodized bracket, clutch and tensioner covers*

**Front Runner
Accessories Page 60**

CUSTOMER SERVICE TEAM

Paul Salas has been into street rodding for over 20 years. He says he just can't wait to finish a car so he can start on another one! Right now he has a '34 Plymouth coupe and the '29 Ford roadster pick-up he's had since high school. Probably wouldn't part with it, do you think?

