

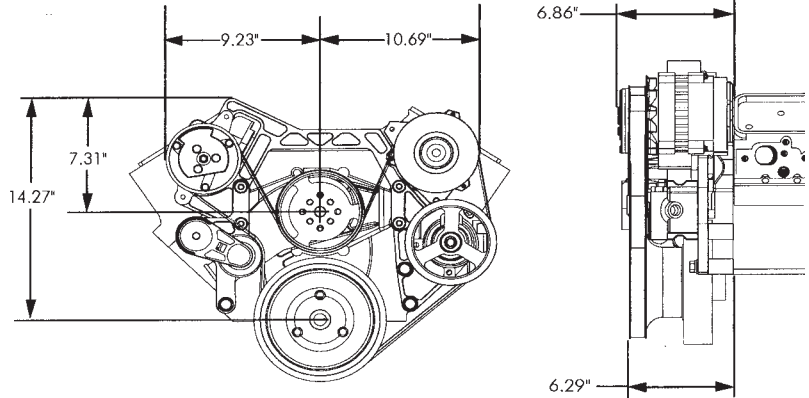

BIG BLOCK CHEVY FRONT RUNNER™ ENGINE DRIVE SYSTEM

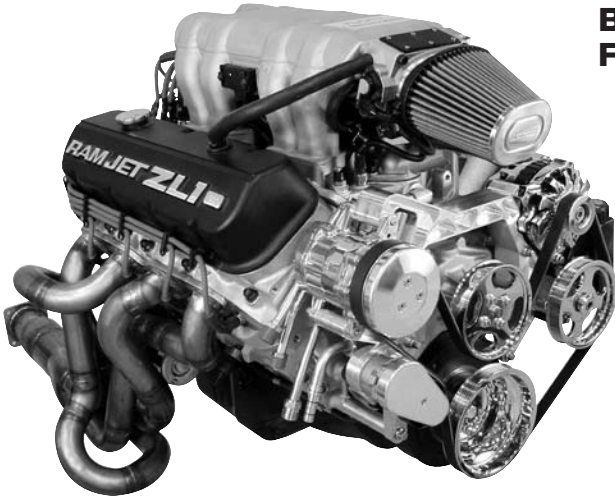

MEASUREMENTS ARE FROM FACE OF BLOCK

Big Block Chevy Front Runner™ Drive System Includes:

- Main Truss Mounting Bracket
- Tensioner Bracket
- Power Steering Bracket (Or Power Steering-Delete Bracket)
- Stewart Hi-Perf Aluminum Water Pump
- ARP Polished Stainless Hardware
- Sanden SD7 Compressor With Formed Aluminum Hardlines
- 140 Amp Alternator
- Compressor Clutch Cover
- Tensioner Cover
- Crankshaft Pulley
- Water Pump Pulley
- Power Steering Pulley (With Power Steering Kit)
- Dayco Perf Serpentine Drive Belt
- Dayco OEM Tensioner
- Delphi-Saginaw Power Steering Pump With Integral Reservoir
- Stainless Extended Heater Hose Nipple



Patents Pending

Bright Big Block Chevy Front Runner™ Drive System

- 174058 With Power Steering (includes Pump)
- 174060-BCA With Power Steering (less Power Steering Pump)
- 175060-BCA Non-Power Steering

Black Hardcoat Big Block Chevy Front Runner™ Drive System

- 174048 With Power Steering (Includes Pump)
- 174050-BCA With Power Steering (Less Power Steering Pump)
- 175050-BCA Non-Power Steering

**Hardcoat kits include black hardcoated pulleys and black anodized bracket, clutch and tensioner covers*

Front Runner Accessories Page 60

CUSTOMER SERVICE TEAM

Roy Arreguin is one of our sales team members. Roy worked as an engineer for over 25 years and has built and restored many hot rods and classic cars as a hobby, with his pride and joy being a 1940 Ford Deluxe coupe.

