

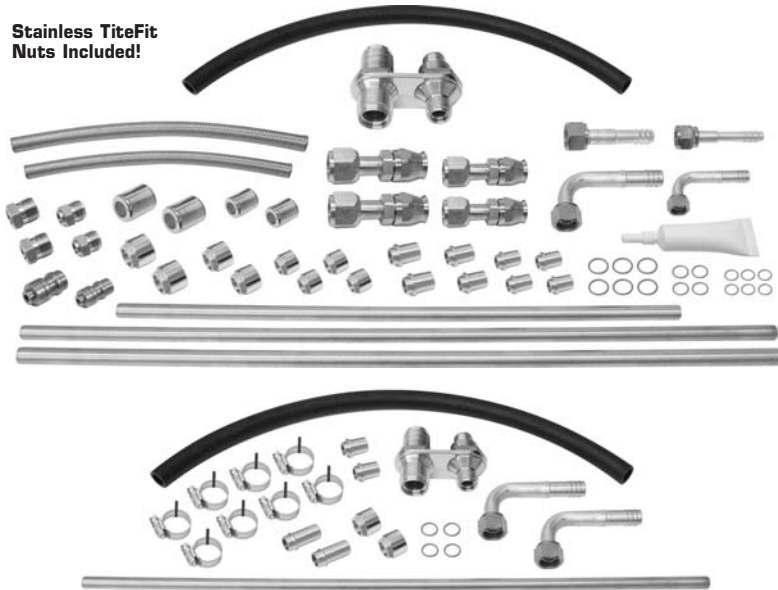

**Stainless TiteFit Nuts Included!**



**Improved Stainless Steel A/C Line Kit (left)**  
 Include straight stainless steel tubing (72" of #6, 36" of #8, and 72" of #10 tubing), tube ends with stainless TiteFit™ nuts, one foot each of stainless Aeroquip #10 & #8 line with straight fittings and a Proline A/C bulkhead plate.

- 31202-VUQ** Proline line kit R-12/134a with 2 way bulkhead
- 31203-VUQ** Proline line kit R-12/134a with 4 way bulkhead
- 31201-VUQ** Proline line kit R-12/134a without bulkhead
- 36701-VUR** Silver solder for S/S lines (30")

**See page 71 for individual stainless parts and fittings.**

**Stainless Steel Heater Line Kit (right)**  
 Include stainless steel tubing (60" of 1/2" #10 tubing) 2 tube ends with nuts, 2 tube ends with barbs, rubber hose for flex areas and 1 heater bulkhead plate.

- 31100-VUQ** Proline heater line kit
- 31101-VUQ** Proline heater kit without bulkhead fittings.

**STAINLESS HARDLINE PARTS**

- Stainless 5/8" barb tube end (heater) 36090-MPA
- Stainless rear exit head fitting (drilled) 36630-MPA (use with 36300-MPA)
- Stainless #10 male O-ring to 3/8" NPT adapter (heater)
- Stainless compressor nut 36300-MPA (use with head fitting)
- Stainless #10 male O-ring to 1/2" NPT adapter (heater)

- Stainless O-ring weld-on line ends #6 .....36400-MPA
- #8 .....36500-MPA
- #10 .....36600-MPA
- Stainless TiteFit™ Nut #6 .....36140-MPA
- #8 .....36240-MPA
- #10 .....36340-MPA
- Stainless male weld-on O-ring nut #6 .....36154-MPA
- #8 .....36255-MPA
- #10 .....36256-MPA
- Stainless tubing stock O6300-VUG - 5/16".....#6 (ordered per foot)
- O6301-VUG - 3/8".....#8 (ordered per foot)
- O6302-VUG - 1/2".....#10 (ordered per foot)

**Proline™ TiteFit™ Hard Line Kits (aluminum)**

Creates compact and professional looking refrigerant line routing down and close to engine. Kits with Proline Tite Fit Nuts built onto line (-VUQ numbers) come fully polished and include machined aluminum line clamps.

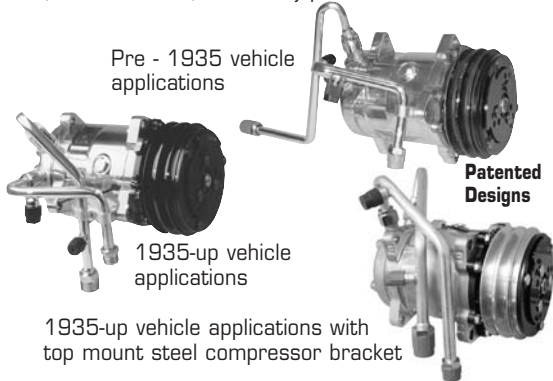

Pre - 1935 vehicle applications

1935-up vehicle applications

1935-up vehicle applications with top mount steel compressor bracket

**Patented Designs**

**For use with Vintage Air ProLine™ compressor bracket**

- 35135-VUG-A** Tite Fit line kit for pre-'35 model cars and trucks 134a
- 35135-VUQ-A** Tite Fit line kit with Tite Fit Nuts for pre-'35 model cars and trucks (polished) 134a
- 35136-VUG-A** Tite Fit line kit for '35-up model cars and trucks 134a
- 35136-VUQ-A** Tite Fit line kit with Tite Fit Nuts for '35-up model cars and trucks (polished) 134a
- 38110-VUQ** Double line clamp with bracket and hardware. (included with all "-VUG" Tite Fit kit part numbers.

**For use with Steel-eez® compressor brackets**

- 35137-VUG-A** Tite Fit line kit for '35-up model cars and trucks 134a
- 35137-VUQ-A** Tite Fit line kit with Tite Fit Nuts for '35-up model cars and trucks (polished) 134a
- 38112-VUQ** Double line clamp with bracket and hardware. (included with all "-VUG" Tite Fit kit part numbers.

**INDUSTRY INVOLVEMENT**

Vintage Air supports many industry and promotional programs. One our favorites is the NSRA 29 Below program. We believe the street rodding hobby needs all the young minds and energy it can get. If you are a young rodder and you are planning on attending a national event soon, be sure to register for this exciting (and rewarding) program.