

# FRONT RUNNER - Ford Small Block

**Patented Design**



289, 302 and 351 Windsor

## SMALL BLOCK FORD FRONT RUNNER™ ENGINE DRIVE SYSTEM

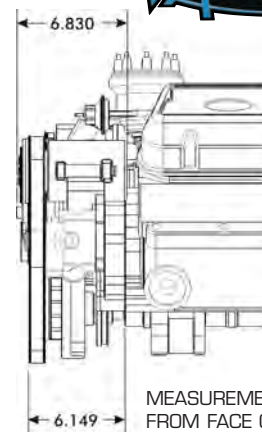
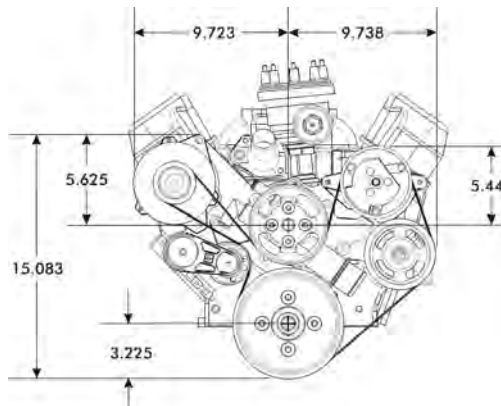

MEASUREMENTS ARE FROM FACE OF BLOCK



### Small Block Ford Front Runner™ Drive System Includes:

- Patented One-Piece Forged Aluminum Timing Cover With Integral Accessory Mounts
- ARP Stainless 12 Point Bolt and Hardware Kit
- Sanden SD7 Compressor With Formed Aluminum Hardlines (Exit Passenger Side)
- 140 Amp Alternator
- Dayco OEM Tensioner
- Timing Cover Gasket Set
- Dayco Perf Serpentine Drive Belt
- Delphi-Saginaw Power Steering Pump With Integral Reservoir
- Compressor Clutch Cover
- Tensioner Cover Kit
- 4 Bolt Crankshaft Pulley
- Stewart Hi-Perf Aluminum Water Pump
- Water Pump Pulley
- Power Steering Pump Pulley (If Power Steering System)

This patented machined forging provides the most rigid and advanced accessory drive system ever.

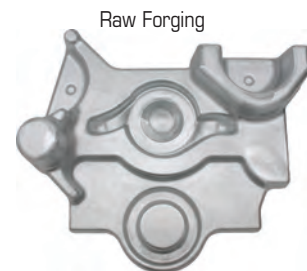

Front Runner Accessories Page 60

### Bright Small Block Ford Front Runner™ Drive System

- 174100 With Power Steering (includes Pump)
- 174103-SFA With Power Steering (less Power Steering Pump)
- 175103-SFA Non-Power Steering

### Black Hardcoat Small Block Ford Front Runner™ Drive System

- 174101 With Power Steering (Includes Pump)
- 174102-SFA With Power Steering (Less Power Steering Pump)
- 175102-SFA Non-Power Steering

Hardcoat kits include black hardcoated pulleys and natural finish bracket, clutch and tensioner covers

#### Notes:

1. Requires electric fuel pump.
2. Requires 4-bolt harmonic balancer. If using Ford 6.753" diameter Motorsports balancer, spacer #199002-HFA is required.
3. If using front sump oil pan, must purchase Stainless Steel Dip Stick Kit sold separately on page 60.



### INDUSTRY RECOGNITION

The Front Runner™ wins "Peoples Choice" Award at 2003 Hot Rod & Restoration Show. The new Front Runner™ engine drive system has become one of the hottest products we have ever introduced. It seems that people everywhere recognize the best solution to serpentine belt problems when they see it.