

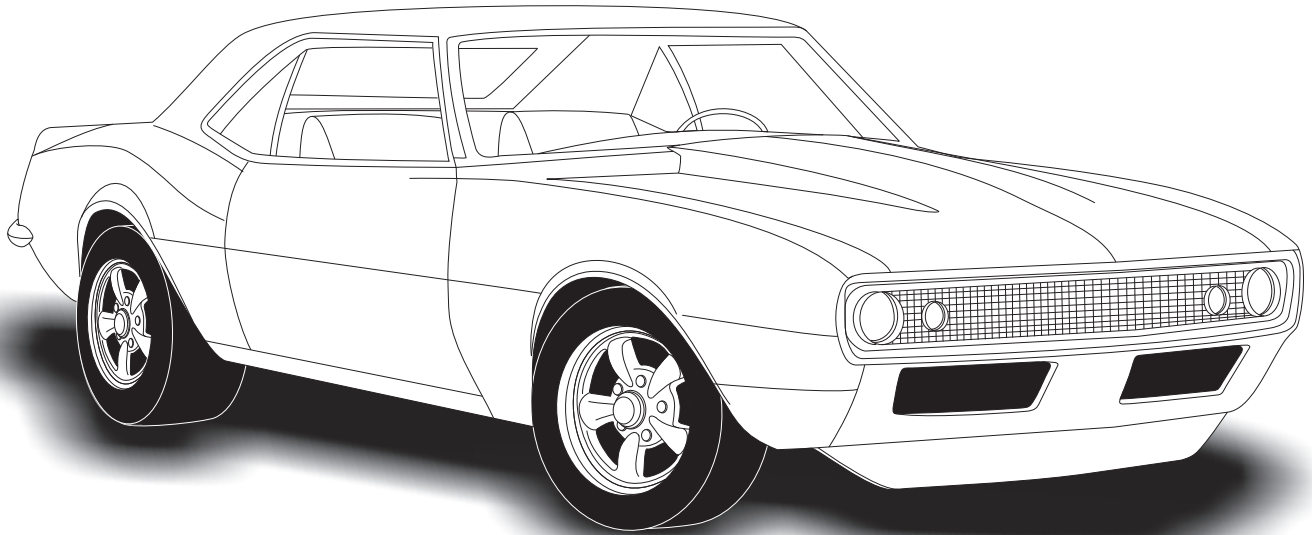

1967-68 CAMARO

w/ & w/o AC CONDENSER w/ DRIER
021067



18865 GOLL ST. - SAN ANTONIO, TX. - 78266 ph.210-654-7171 - fax 210-654-3113



Table of Contents

PAGES

1. COVER
2. TABLE OF CONTENTS
3. PACKING LIST/PARTS DISCLAIMER
4. CONDENSER BRACKET INSTALLATION
FIGURE 1
5. TOP MOUNTING BRACKET INSTALLATION & DRIER INSTALLATION
FIGURES 2 & 3
6. HARDLINE INSTALLATION, LUBRICATING O-RINGS &
HOOD LATCH ASSEMBLY
FIGURES 4 & 5
7. CONDENSER INSTALLATION
FIGURES 6 & 7
8. CONDENSER INSTALLATION CONT
FIGURES 8 & 9
9. CONDENSER INSTALLATION CONT
FIGURES 10 & 11
10. PACKING LIST



1967-68 CAMARO w/ w/o AC CONDENSER w/ DRIER

1967-68 CAMARO w/ or w/o FACTORY AIR w/ DRIER CONDENSER KIT PACKING LIST

CONDENSER KIT
021067

No.	QTY.	PART No.	DESCRIPTION
1.	1	03766-VUC	14" X 22" PARALLEL FLOW COND.
2.	2	07113-VUB	DRIER CLAMP
3.	1	07321-VUC	DRIER
4.	1	18148-VUB	5/16" COARSE NUT
5.	2	18247-VUB	#10 SHEETMETAL SCREW
6.	10	18249-VUB	10/24" X 3/8" PH PAN HEAD
7.	10	18260-VUB	10/24" NUT w/STAR WASHER
8.	1	18610-VUB	5/16" LOCK WASHER
9.	2	18611-VUB	5/16" FLAT WASHER
10.	1	18310-VUB	5/16-18" x 1 1/2" COARSE BOLT
11.	2	18977-VUB	5/16" "U" NUT
12.	3	33857-VUF	#6 O'RING
13.	1	33858-VUF	#8 O'RING
14.	1	35367-VCG	#8 COND./HARDLINE
15.	1	35368-VCG	#6 HRDLN DRIER TO CONDENSER
16.	1	64268-VCB	67-68 CAMARO COND. BRKT. TOP
17.	1	64368-VCB	67-68 CAMARO COND. BRKT. BTM. RT
18.	1	64468-VCB	67-68 CAMARO COND. BRKT. BTM. LF
19.	1	65998-VUB	UNIVERSAL DRIER BRKT. 14-3/4"
20.	1	35067-VCG	#6 HARDLINE/COMPRESSOR LINE
21.	1	11079-VUS	MALE BINARY SWITCH
22.	1	23127-VUW	72" COMPRESSOR LEAD

**** BEFORE BEGINNING INSTALLATION OPEN ALL PACKAGES AND CHECK CONTENTS OF SHIPMENT. PLEASE REPORT ANY SHORTAGES DIRECTLY TO VINTAGE AIR WITHIN 15 DAYS. AFTER 15 DAYS, VINTAGE AIR WILL NOT BE RESPONSIBLE FOR MISSING OR DAMAGED ITEMS.**

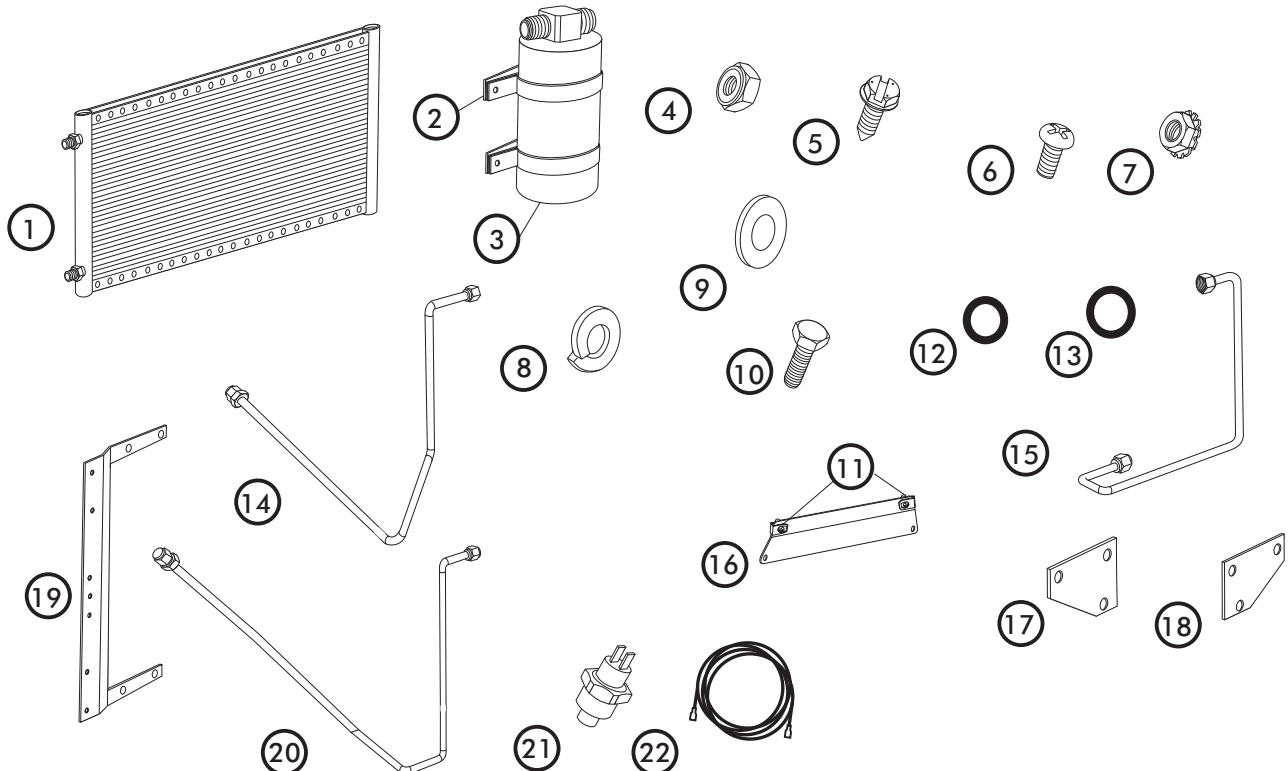

NOTE: IMAGES MAY NOT DEPICT ACTUAL PARTS AND QUANTITIES. REFER TO PACKING LIST FOR ACTUAL PARTS AND QUANTITIES



1967-68 CAMARO w/ w/o AC CONDENSER w/ DRIER

CONDENSER BRACKET INSTALLATION

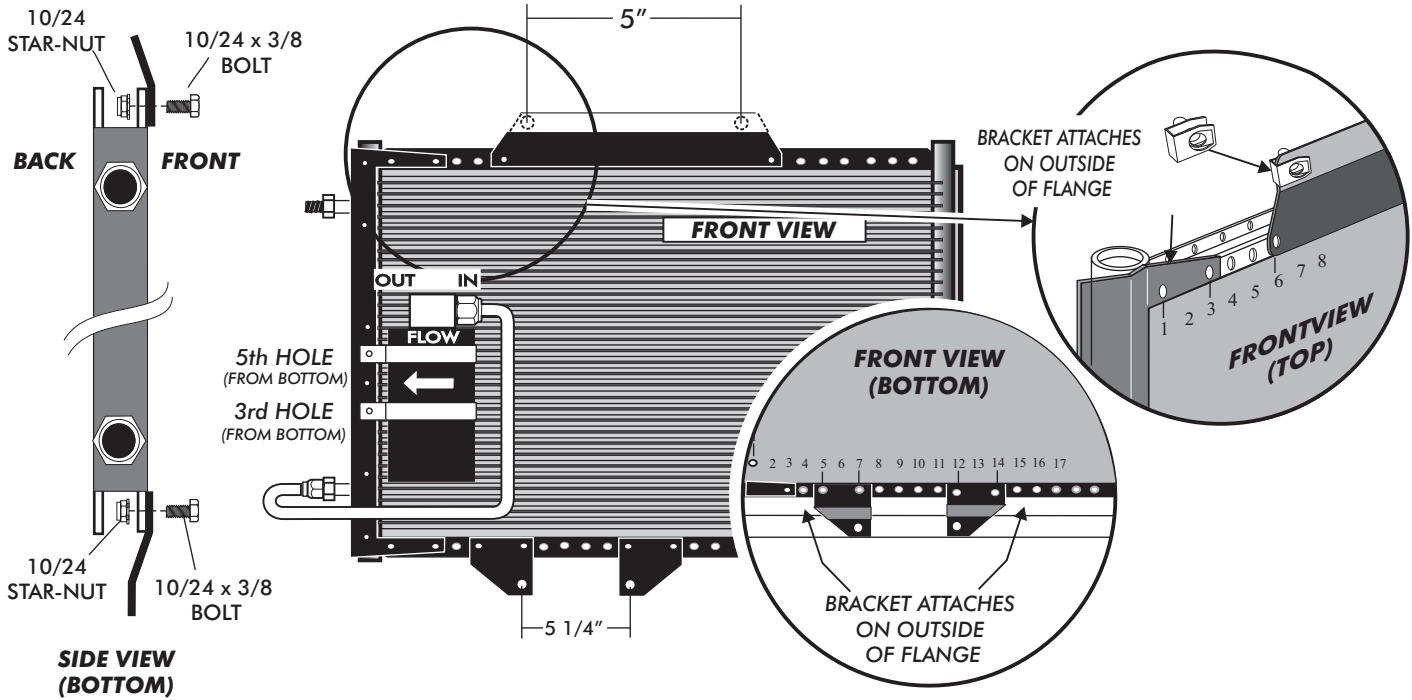

ON A WORK BENCH ASSEMBLE CONDENSER AS FOLLOWS:

- INSTALL DRIER MOUNTING BRACKET ON TO CONDENSER USING (4) 10/24 x 3/8 PAN HEAD SCREWS AND (4) 10/24 NUTS WITH STAR WASHERS. SEE FIGURE 1 BELOW.
- NOTE: BRACKETS MOUNT THROUGH THE FIRST AND THIRD HOLE IN THE CONDENSER.**

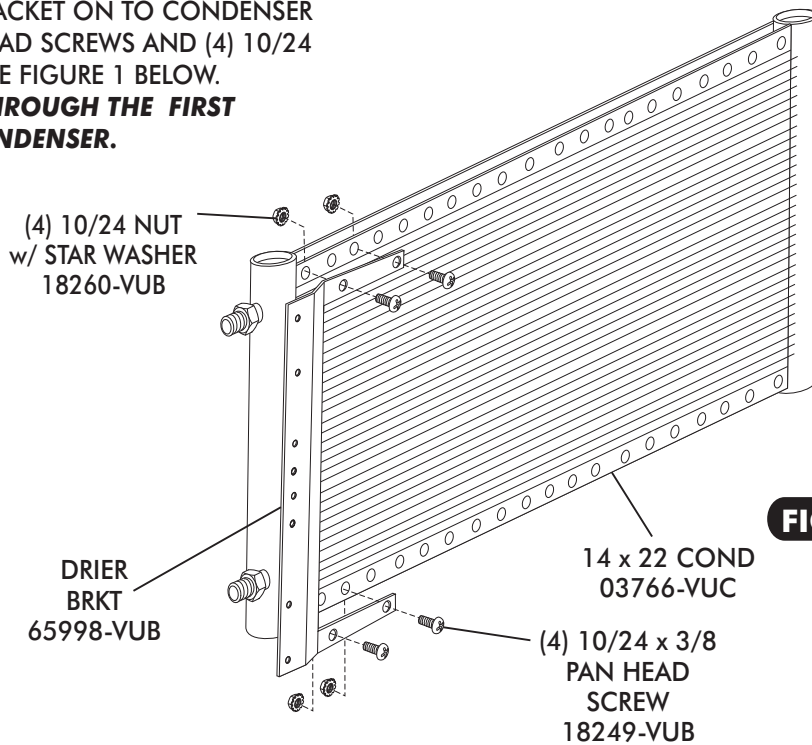

FIGURE 1



TOP MOUNTING BRACKET INSTALLATION

- INSTALL TOP MOUNTING BRACKET ON TO CONDENSER USING (2) 10/24 x 3/8 PAN HEAD SCREWS AND (2) 10/24 NUTS WITH STAR WASHERS. SEE FIGURE 2 BELOW. **NOTE: BRACKET MOUNT THROUGH THE 6TH HOLE FROM THE LEFT SIDE OF THE CONDENSER.**

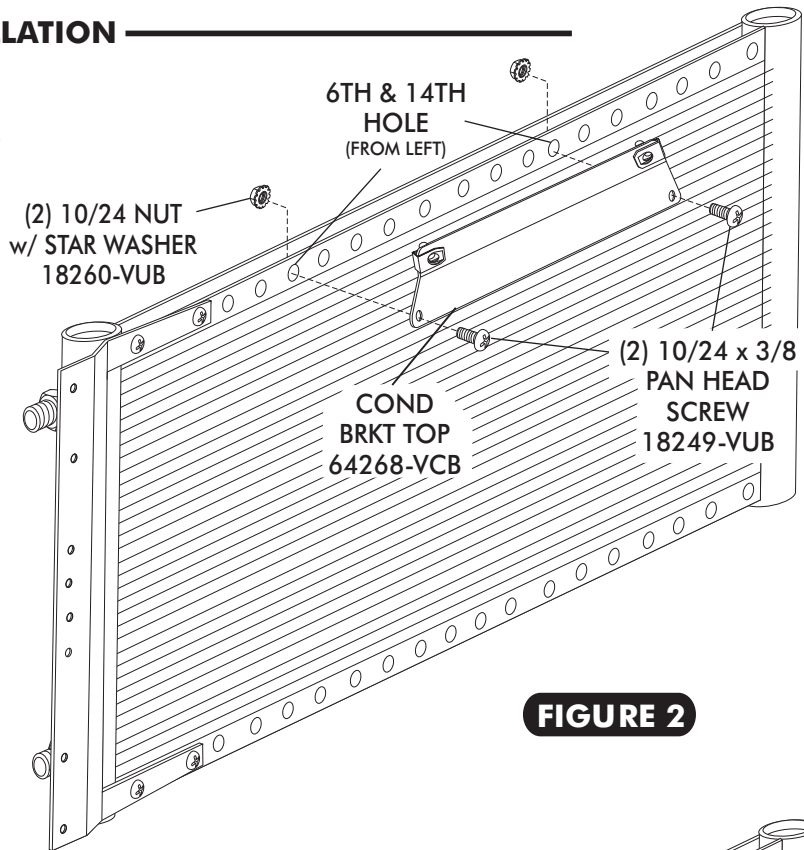

FIGURE 2

DRIER INSTALLATION

- INSTALL DRIER CLAMPS ON DRIER AS SHOWN
- USING (2) #10 x 1/2" SHEETMETAL SCREWS INSTALL DRIER ON BRACKET IN THE 3RD AND 5TH HOLES FROM THE BOTTOM AS SHOWN FIGURE 3.

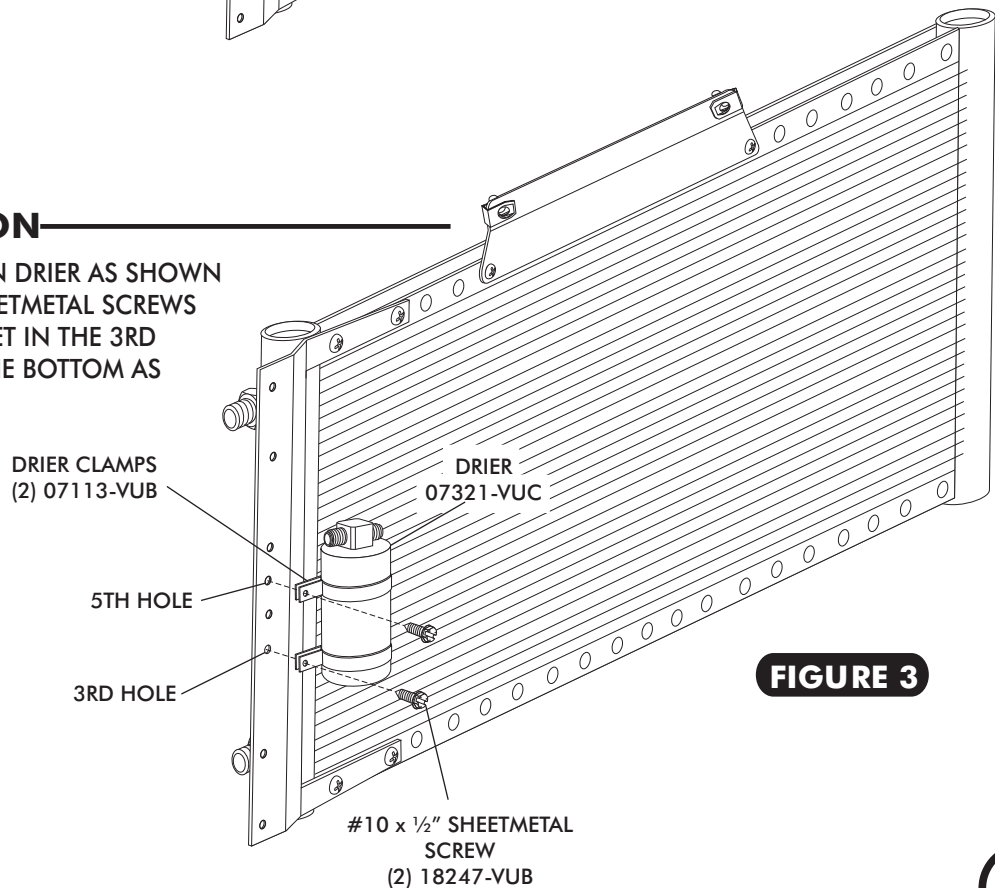

FIGURE 3



HARDLINE INSTALLATION

- LUBRICATE (2) #6 O-RINGS (SEE FIGURE 4a, BELOW) AND INSTALL THE #6 DRIER/CONDENSER HARDLINE AS SHOWN IN FIGURE 4 BELOW. TIGHTEN FITTINGS AS SHOWN IN FIGURE 4a, BELOW.
- USING (4) 10/24 x 3/8 PAN HEAD SCREWS WITH (4) 10/24 NUTS WITH STAR WASHERS INSTALL THE (2) LOWER CONDENSER MOUNTING BRACKETS AS SHOWN IN FIGURE 4

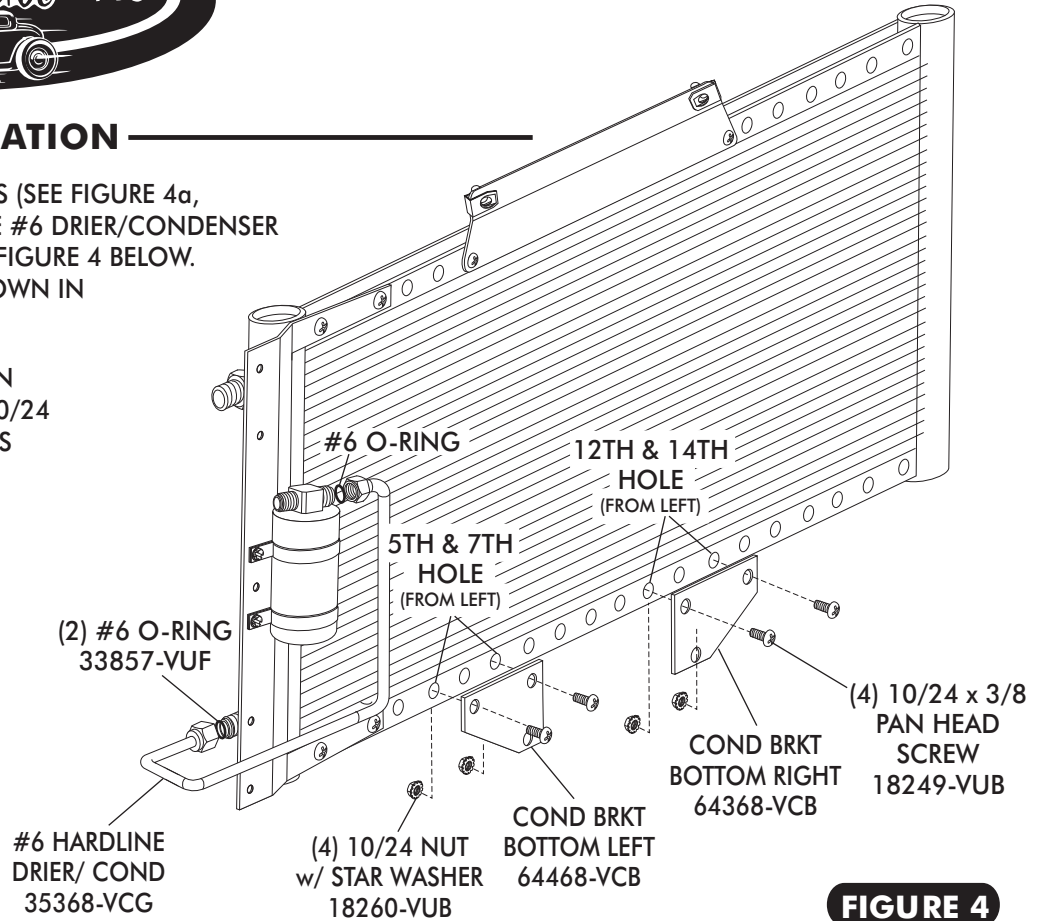

FIGURE 4

FOR A PROPER SEAL OF FITTINGS:
INSTALL SUPPLIED O-RINGS AS SHOWN AND LUBRICATE WITH SUPPLIED OIL.

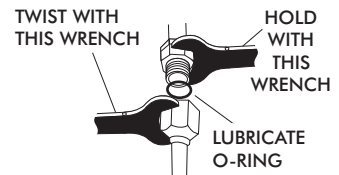
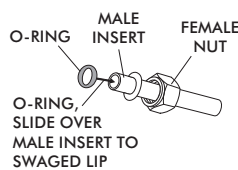
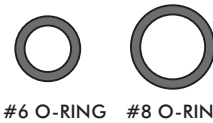

FIGURE 4a

HOOD LATCH ASSEMBLY

- REMOVE OEM HOOD LATCH ASSEMBLY SEE FIGURE 5 BELOW.

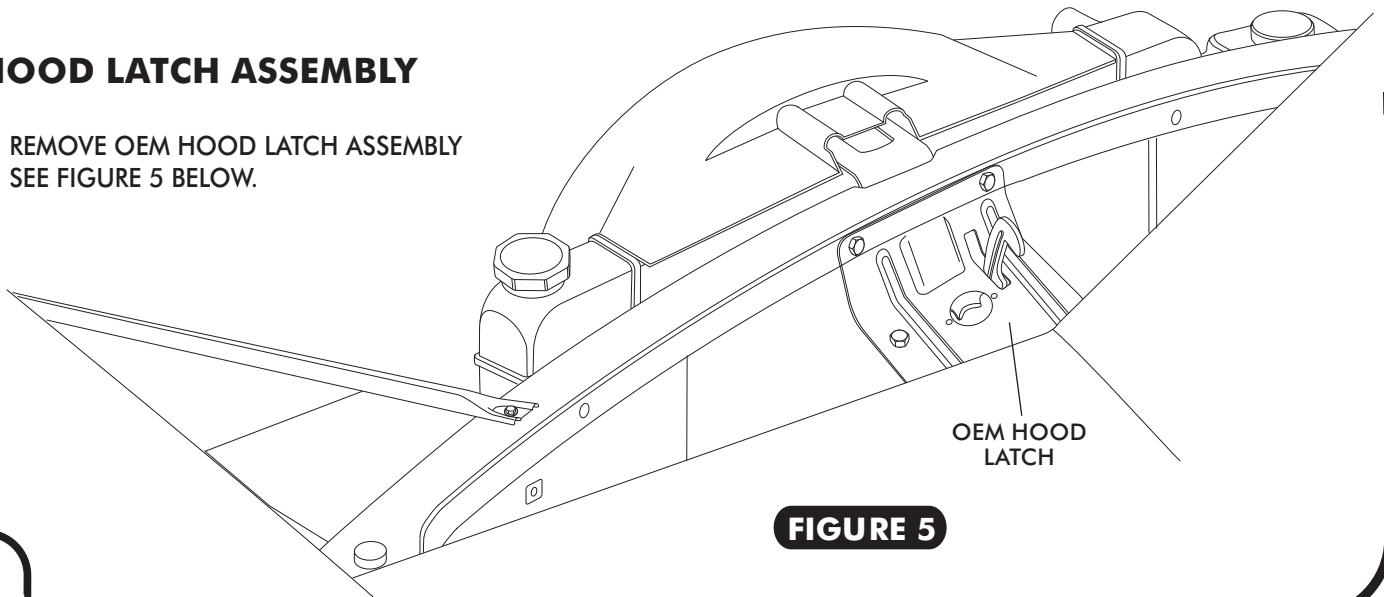

FIGURE 5



1967-68 CAMARO w/ w/o AC CONDENSER w/ DRIER

CONDENSER INSTALLATION

- INSTALL CONDENSER AS SHOWN BELOW, LOWER CONDENSER WITH HARDLINES BETWEEN THE FRONT SIDE OF THE CORE SUPPORT AND THE FRONT HEADER SEE FIGURE 6 BELOW.

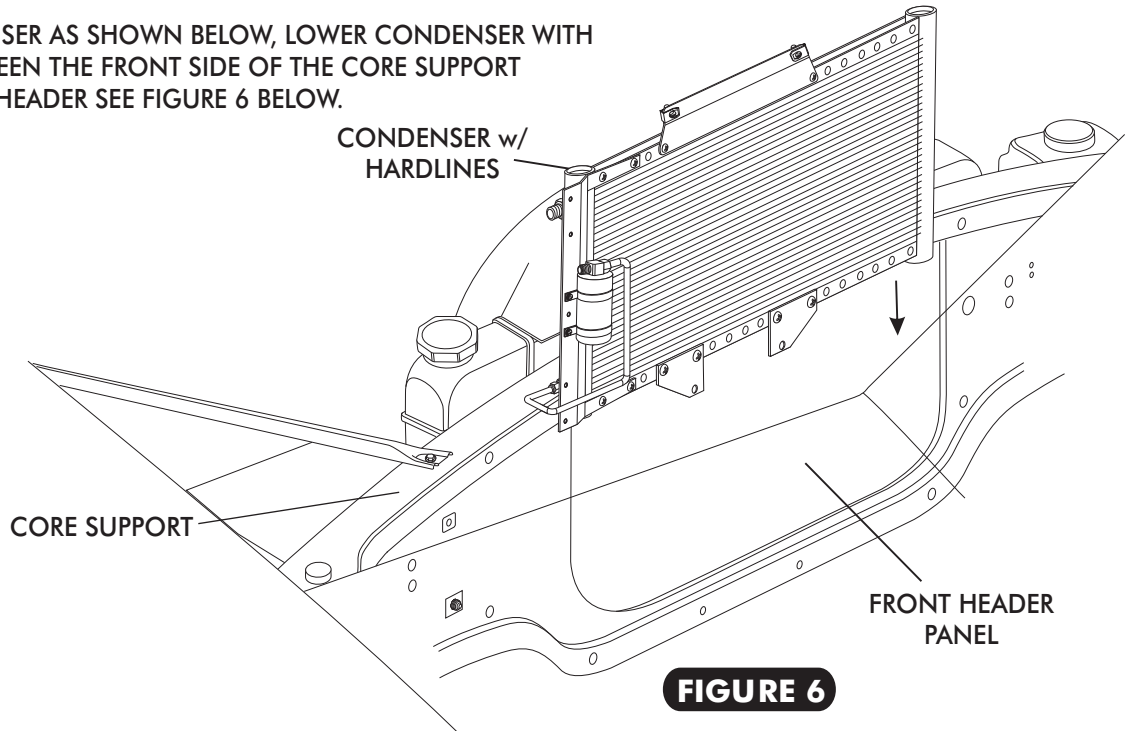

FIGURE 6

- NOTE: THE TOP MOUNTING BRACKET GOES ON THE BACKSIDE OF THE CORE SUPPORT.
- SECURE THE BOTTOM DRIVER SIDE OF THE CONDENSER TO THE CORE SUPPORT USING A 5/16-18 x 1 1/2" HEX BOLT, FLAT WASHER, LOCK WASHER, AND 5/16 HEX NUT. SEE FIGURE 7, BELOW.
- SECURE THE BOTTOM PASSENGER SIDE OF THE CONDENSER TO THE CORE SUPPORT USING OEM BOLT. SEE FIGURE 7, BELOW.

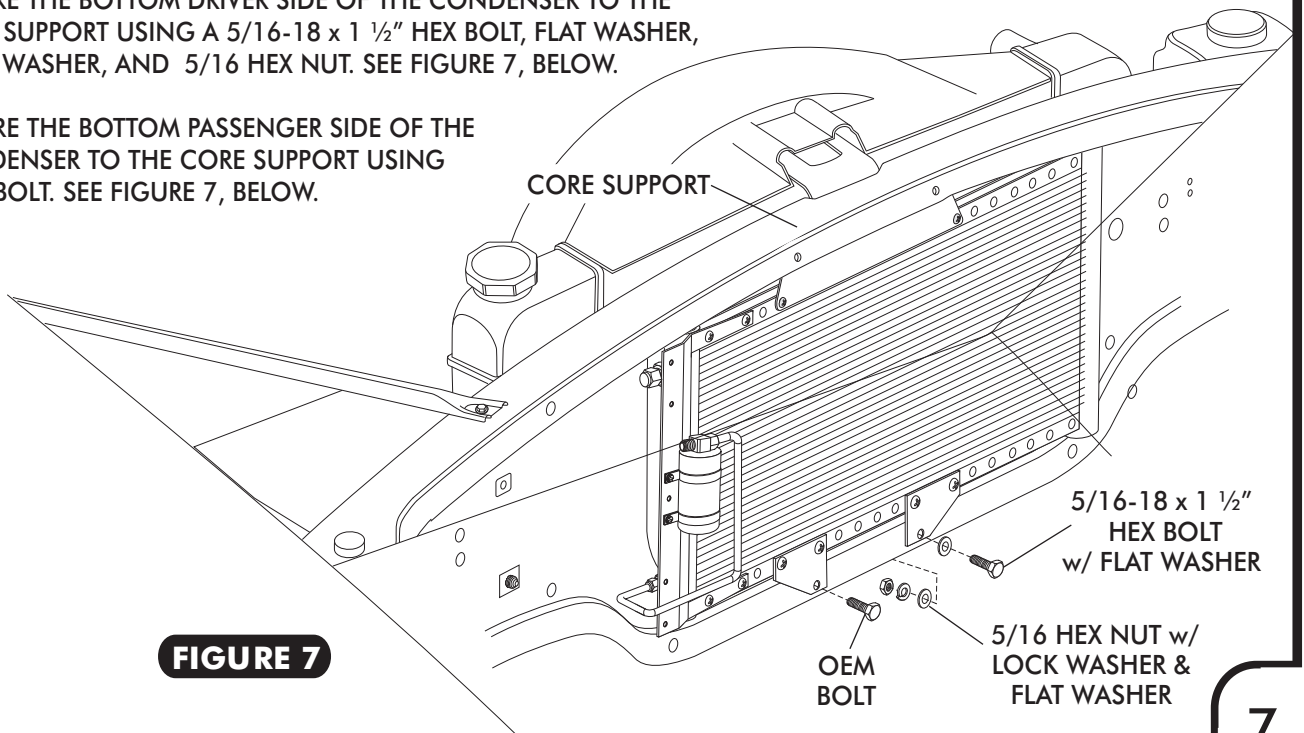

FIGURE 7



CONDENSER INSTALLATION CONT.

- USING OEM BOLTS RE-INSTALL HOOD LATCH ASSEMBLY, INSTALL OEM BOLTS THROUGH THE HOOD LATCH ASSEMBLY THROUGH THE CORE SUPPORT AND THREAD BOLTS INTO U-NUTS ON THE TOP CONDENSER BRACKET. SEE FIGURE 8 BELOW

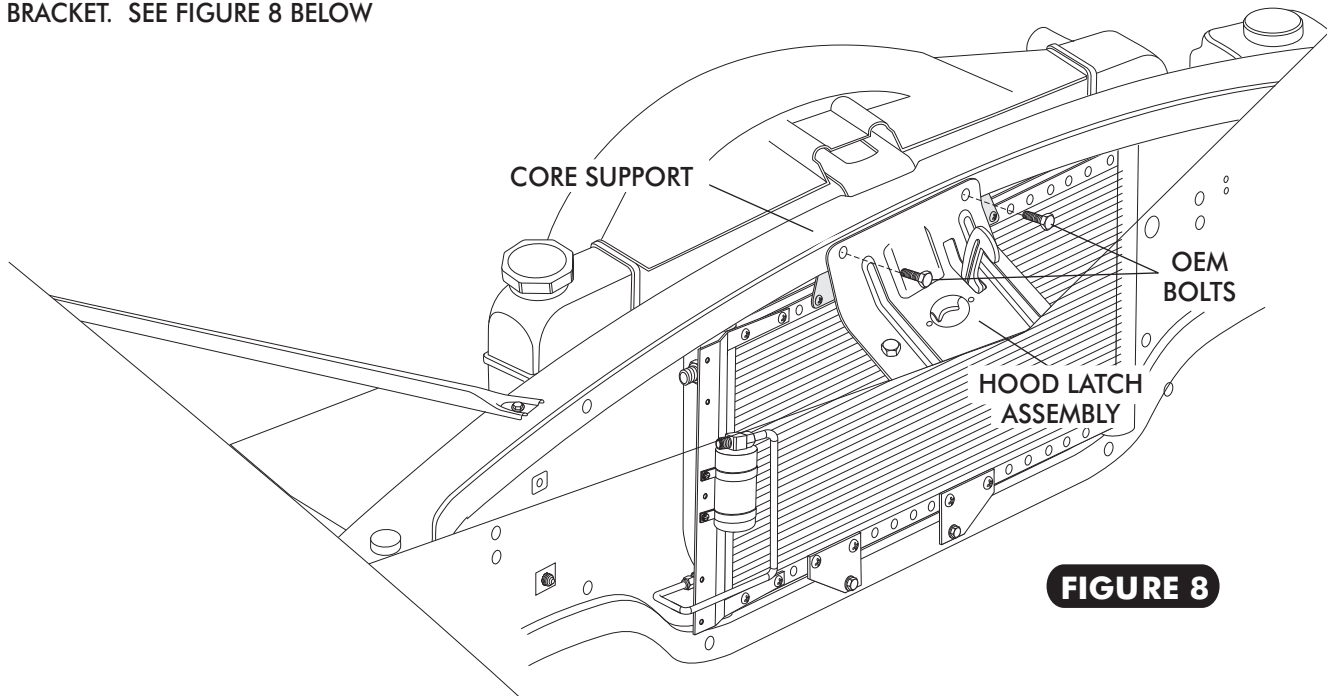

FIGURE 8

- LUBRICATE A #6 O-RING (SEE FIGURE 4a, PAGE 6) AND INSTALL THE #6 DRIER/FENDERWELL HARDLINE AS SHOWN IN FIGURE 9 BELOW. TIGHTEN FITTINGS AS SHOWN IN FIGURE 4a, PAGE 6.

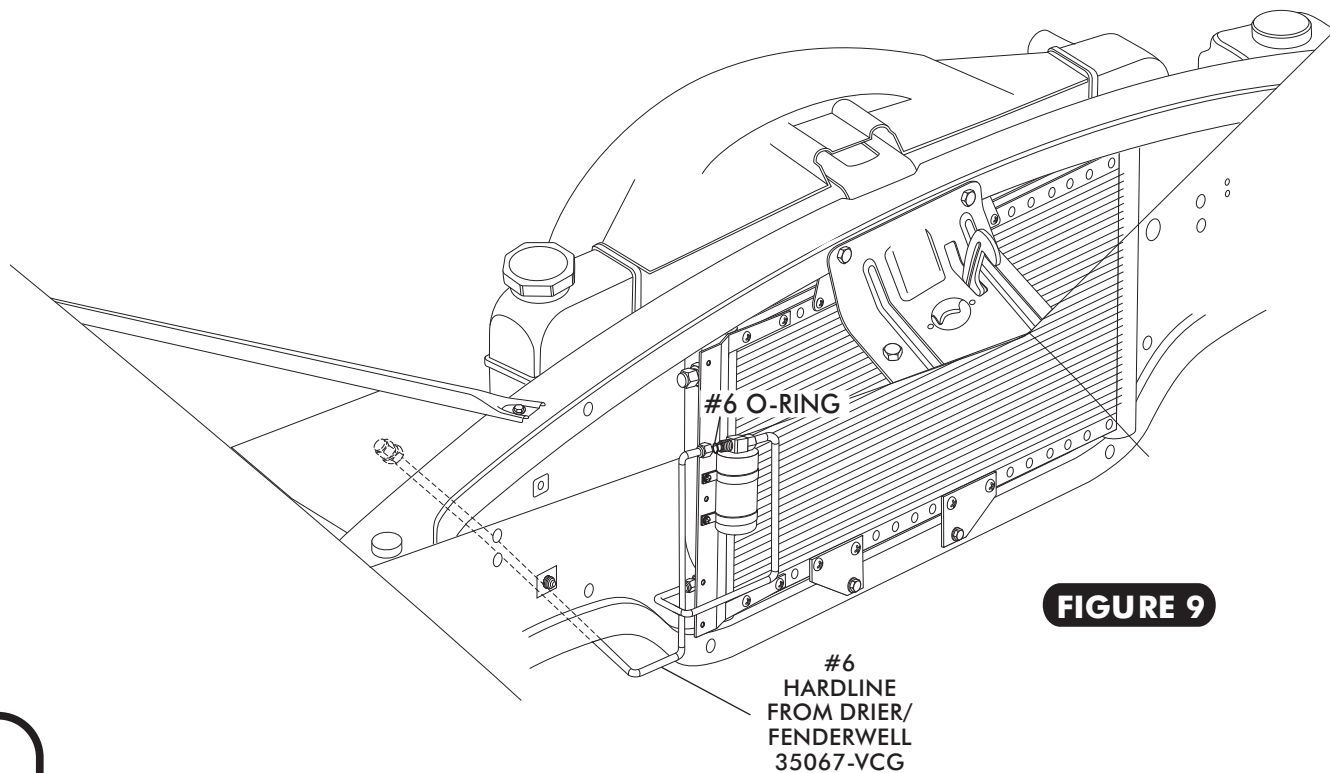

FIGURE 9



1967-68 CAMARO w/ w/o AC CONDENSER w/ DRIER

CONDENSER INSTALLATION CONT.

- LUBRICATE A #8 O-RING (SEE FIGURE 4a, PAGE 6) AND INSTALL THE #8 HARDLINE FROM CONDENSER/ FENDERWELL AS SHOWN IN FIGURE 10 BELOW. TIGHTEN FITTINGS AS SHOWN IN FIGURE 4a, PAGE 6.

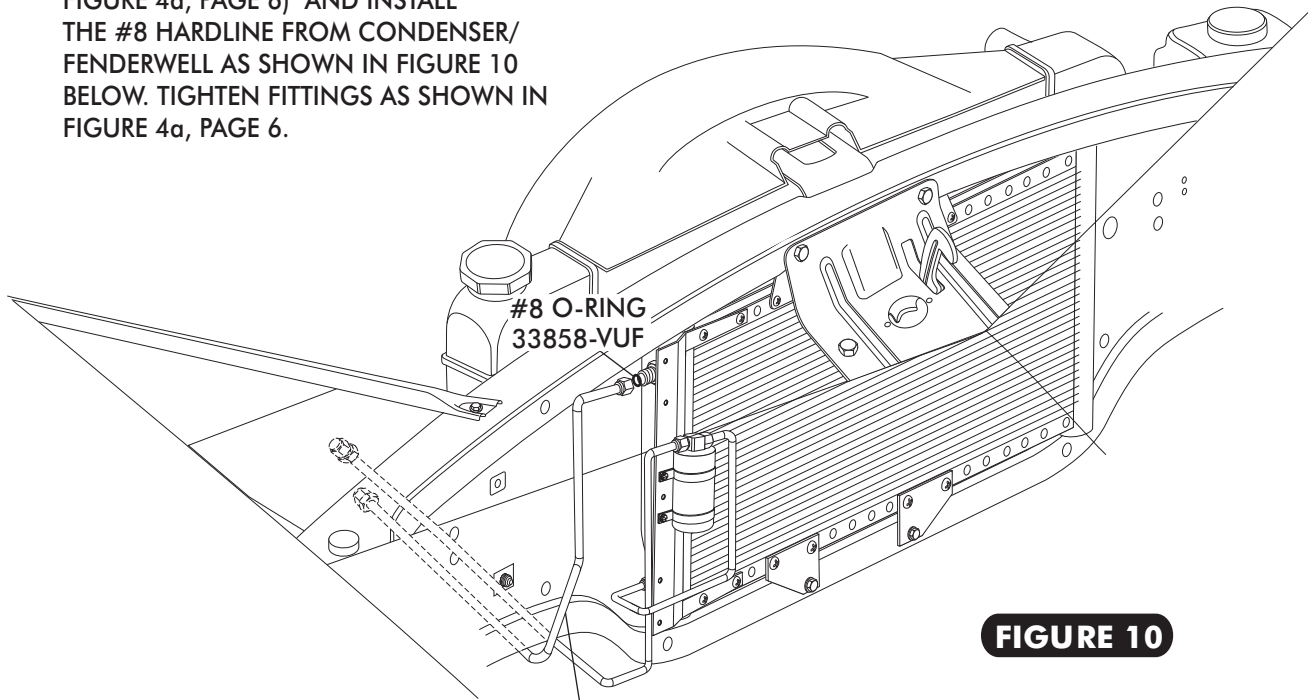

FIGURE 10

#8 CONDENSER
HARDLINE
35367-VCG

- INSTALL BINARY SWITCH ON DRIER AS SHOWN IN FIGURE 11 BELOW.

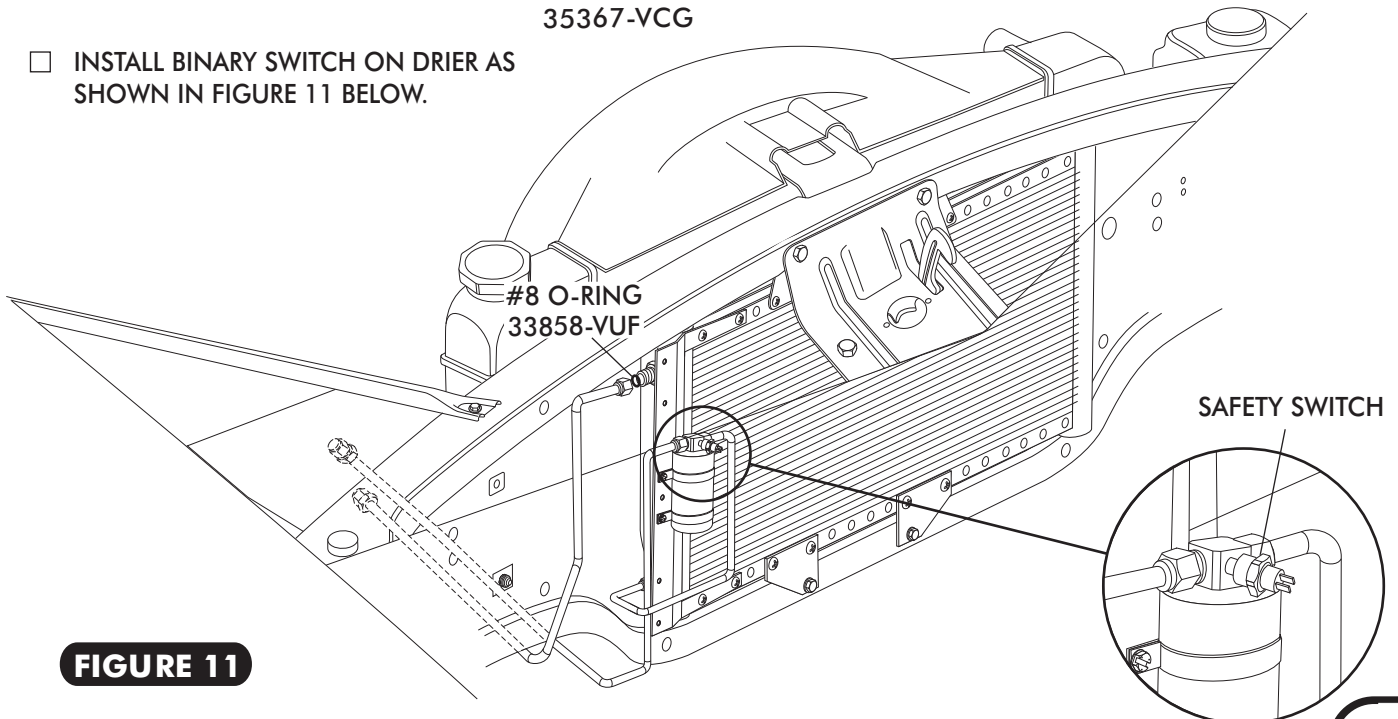

FIGURE 11



1967-68 CAMARO w/ w/o AC CONDENSER w/ DRIER

1967-68 CAMARO w/ or w/o FACTORY AIR w/ DRIER CONDENSER KIT PACKING LIST

CONDENSER KIT
021067

No.	QTY.	PART No.	DESCRIPTION
1.	1	03766-VUC	14" X 22" PARALLEL FLOW COND.
2.	2	07113-VUB	DRIER CLAMP
3.	1	07321-VUC	DRIER
4.	1	18148-VUB	5/16" COARSE NUT
5.	2	18247-VUB	#10 SHEETMETAL SCREW
6.	10	18249-VUB	10/24" X 3/8" PH PAN HEAD
7.	10	18260-VUB	10/24" NUT w/STAR WASHER
8.	1	18610-VUB	5/16" LOCK WASHER
9.	2	18611-VUB	5/16" FLAT WASHER
10.	1	18310-VUB	5/16-18" x 1 1/2" COARSE BOLT
11.	2	18977-VUB	5/16" "U" NUT
12.	3	33857-VUF	#6 O'RING
13.	1	33858-VUF	#8 O'RING
14.	1	35367-VCG	#8 COND./HARDLINE
15.	1	35368-VCG	#6 HRDLN DRIER TO CONDENSER
16.	1	64268-VCB	67-68 CAMARO COND. BRKT. TOP
17.	1	64368-VCB	67-68 CAMARO COND. BRKT. BTM. RT
18.	1	64468-VCB	67-68 CAMARO COND. BRKT. BTM. LF
19.	1	65998-VUB	UNIVERSAL DRIER BRKT. 14-3/4"
20.	1	35067-VCG	#6 HARDLINE/COMPRESSOR LINE
21.	1	11079-VUS	MALE BINARY SWITCH
22.	1	23127-VUW	72" COMPRESSOR LEAD

CHECKED BY: _____
 PACKED BY: _____
 DATE: _____

