

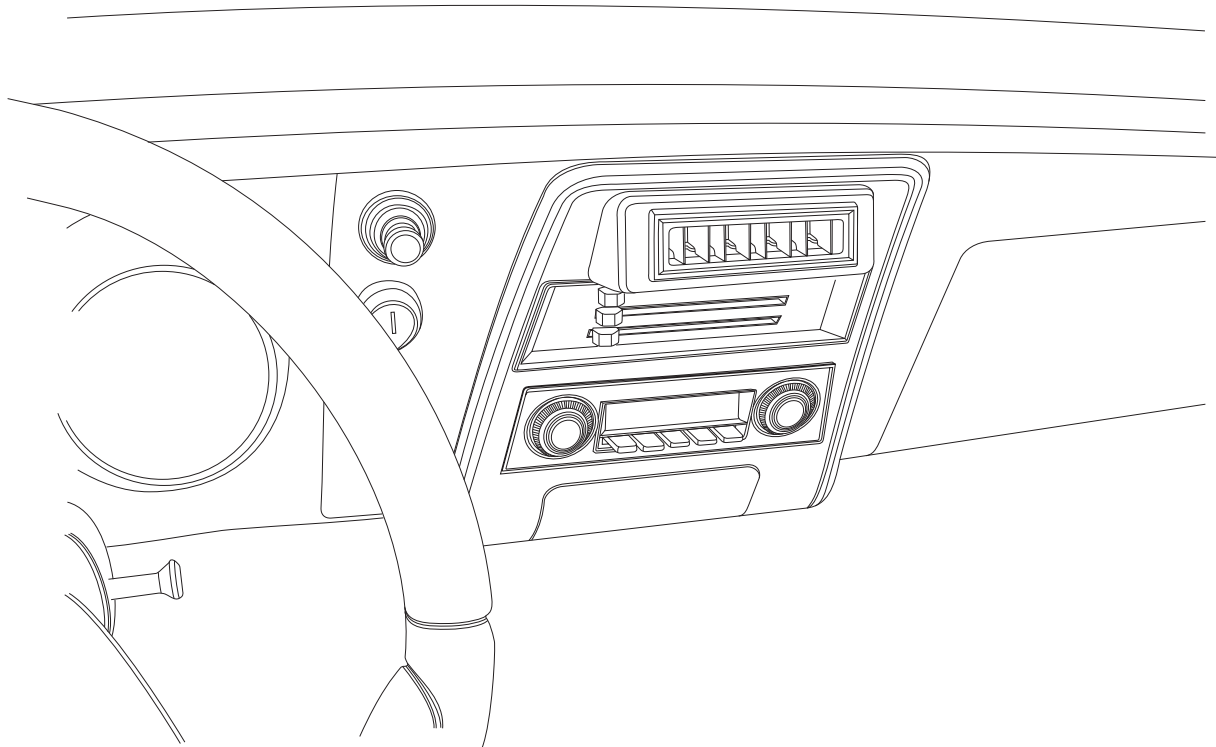

1967-68 CAMARO

w/o AC CONTROL PANEL
CONVERSION KIT
475168



18865 GOLL ST. - SAN ANTONIO, TX. - 78266 ph.210-654-7171 - fax 210-654-3113



Table of Contents

PAGES

1. COVER
2. TABLE OF CONTENTS
3. PACKING LIST/ PARTS DISCLAIMER
4. REMOVING OEM CONTROL PANEL & PLACARD INSTALLATION
FIGURES 1 & 2
5. SLIDE POT ASM MODIFICATIONS & SLIDE POT ASM MOUNTING
CLAMP INSTALLATION. FIGURES 3 & 4
6. SLIDE POT ASM INSTALLATION
FIGURE 5
7. SLIDE POT ASM INSTALLATION CONT.
FIGURES 5a & 5b
8. SLIDE POT ASM INSTALLATION
FIGURES 6 & 6a
9. SLIDE POT ASM INSTALLATION CONT.
FIGURES 6b & 7
10. SLIDE POT ASM INSTALLATION CONT.
FIGURES 7a & 7b
11. FINAL STEP
FIGURE 8
12. CONTROL PANEL CALIBRATION PROCEDURE
13. WIRING DIAGRAM
14. OPERATION OF CONTROLS
15. CONTROL PANEL KIT PACKING LIST



CONTROL KIT PACKING LIST

**CONTROL KIT
475168**

No.	QTY.	PART No.	DESCRIPTION
1.	1	484168	67-68 CAMARO w/o AC CNTRL PNL MODE LABEL
2.	3	112002-SUA	SLIDE POT ASM
3.	1	232006-VUR	GEN IV UNIVERSAL CONTROL HARNESS (TYPE B)
4.	3	65976-VUE	3/16" PUSH-ON RING
5.	3	491010-VUR	SLIDE POT CLAMP
6.	5	21301-VUP	4" TIE WRAP
7.	1	231520	GROUND WIRE
8.	4	18235-VUB	#8 x 1/2" PAN HEAD SCREW

**** BEFORE BEGINNING INSTALLATION OPEN ALL PACKAGES AND CHECK CONTENTS OF SHIPMENT. PLEASE REPORT ANY SHORTAGES DIRECTLY TO VINTAGE AIR WITHIN 15 DAYS. AFTER 15 DAYS, VINTAGE AIR WILL NOT BE RESPONSIBLE FOR MISSING OR DAMAGED ITEMS.**



①

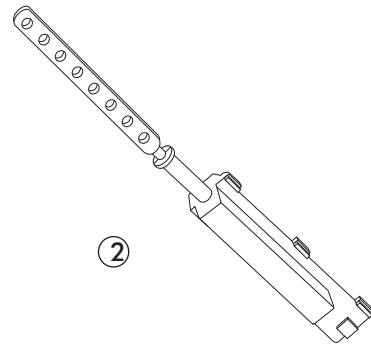

②

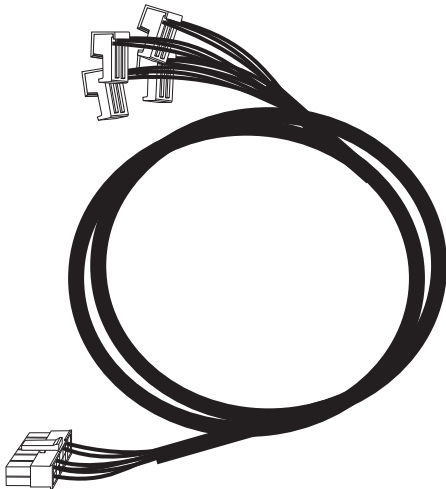

③



④

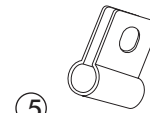

⑤

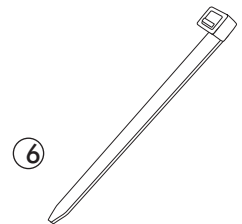

⑥



⑦

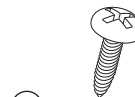

⑧



1967-68 CAMARO w/o AC CNTRL PNL

REMOVING OEM CONTROL PANEL

- REMOVE THE (4) OEM MOUNTING SCREWS FROM DASH BEZEL, UNDER THE DASH. SEE FIGURE 1 BELOW.
- REMOVE THE CONTROL PANEL
- DISCONNECT CABLES, AND WIRES FROM BACK OF CONTROL PANEL.

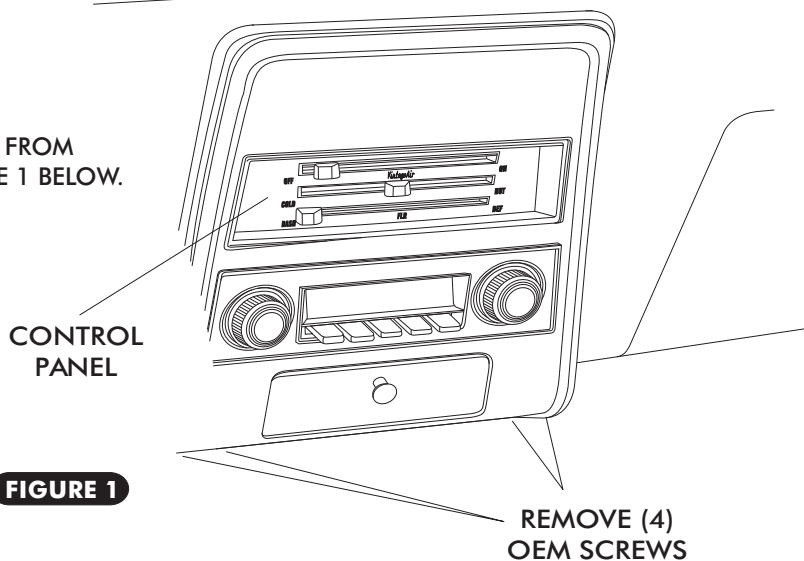

FIGURE 1

PLACARD INSTALLATION CONT.

- REMOVE LEVER KNOBS.
- REMOVE THE (4) CONTROL PANEL FACE PLATE MOUNTING RIVETS. USE A 9/64 DRILL BIT TO DRILL OUT RIVETS.
- REMOVE OEM PLACARD FROM CONTROL PANEL.
- INSTALL MODE LABEL ON FRONT SIDE OF OEM PLACARD.
- INSTALL PLACARD AND CONTROL PANEL FACE PLATE. SECURE CONTROL PANEL FACE PLATE TO CONTROL PANEL USING (4) #8 x 1/2 PAN HEAD SCREWS.
- RE-INSTALL KNOBS.

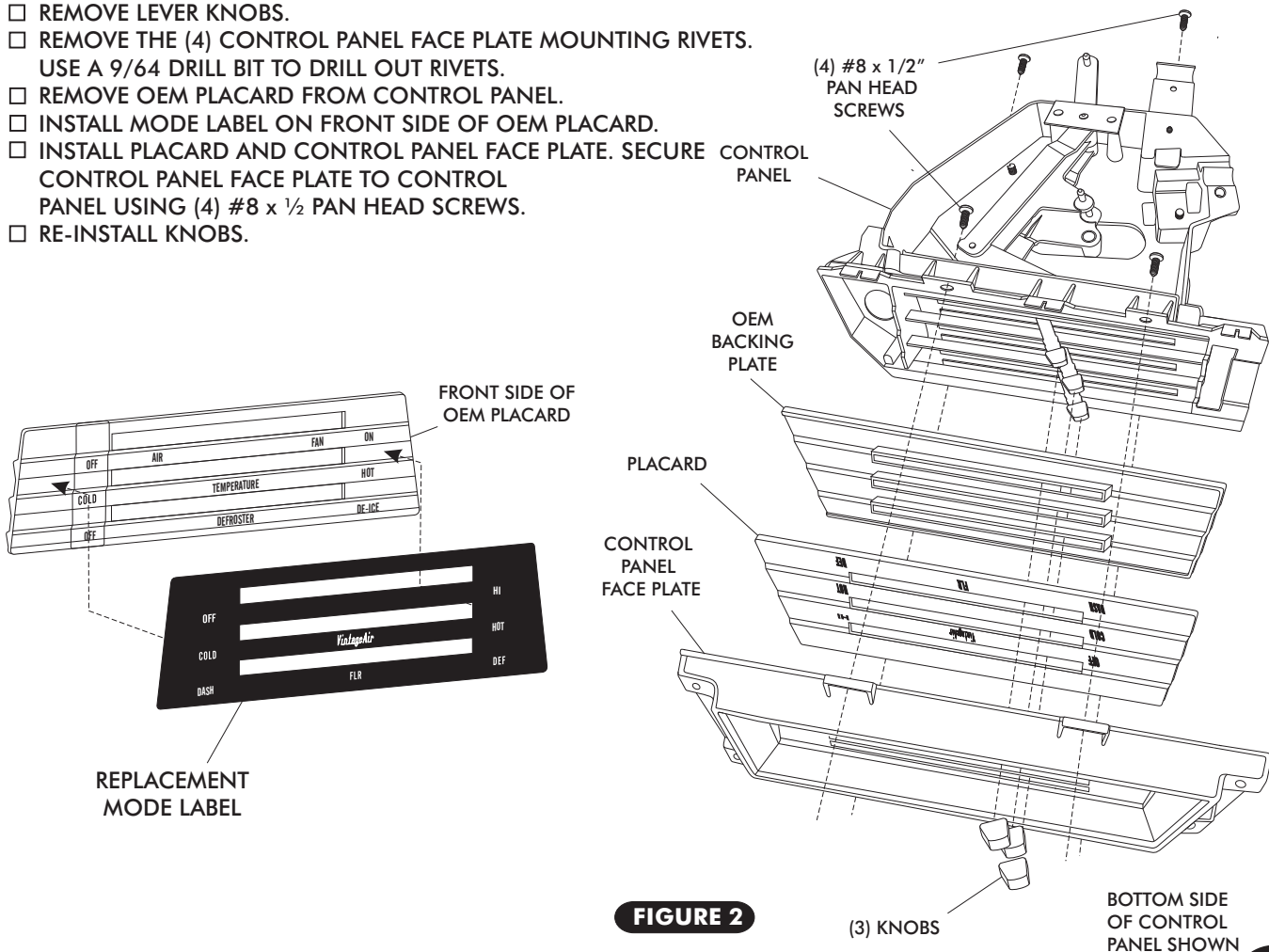
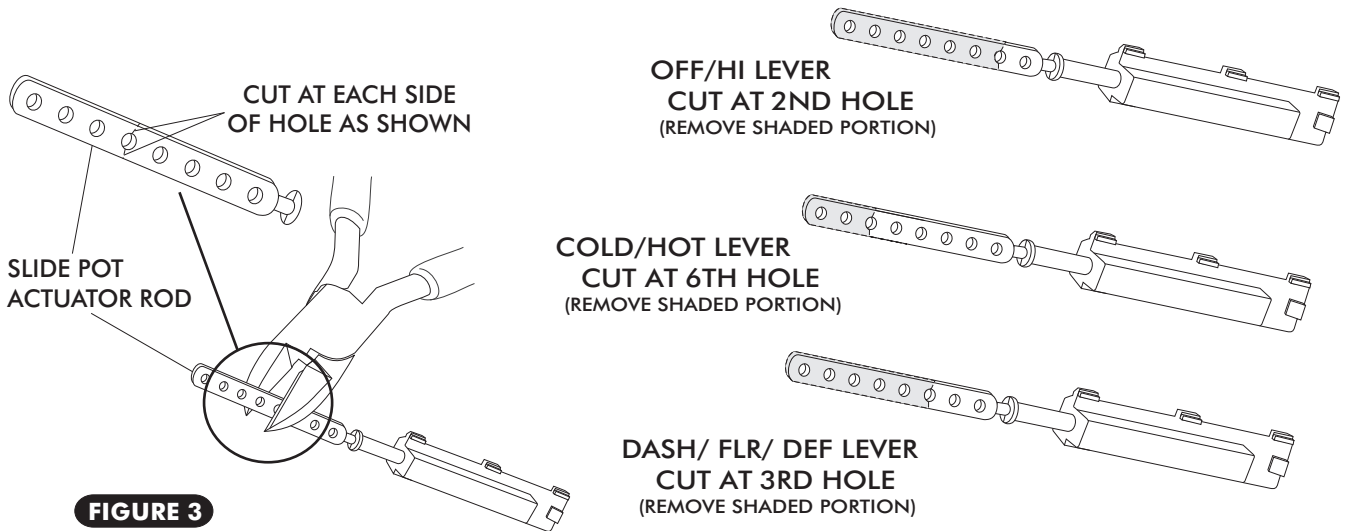

FIGURE 2



SLIDE POT ASSEMBLY MODIFICATIONS

- LOCATE THE THREE SLIDE POT ASSEMBLIES, AND USING A PAIR OF WIRE CUTTERS, CUT SLIDE POT ACTUATOR RODS AS SHOWN BELOW IN FIGURE 3.



SLIDE POT ASSEMBLY MOUNTING CLAMP INSTALLATION

- INSTALL SLIDE POT ASM MOUNTING CLAMPS, SEE FIGURE 4 BELOW.

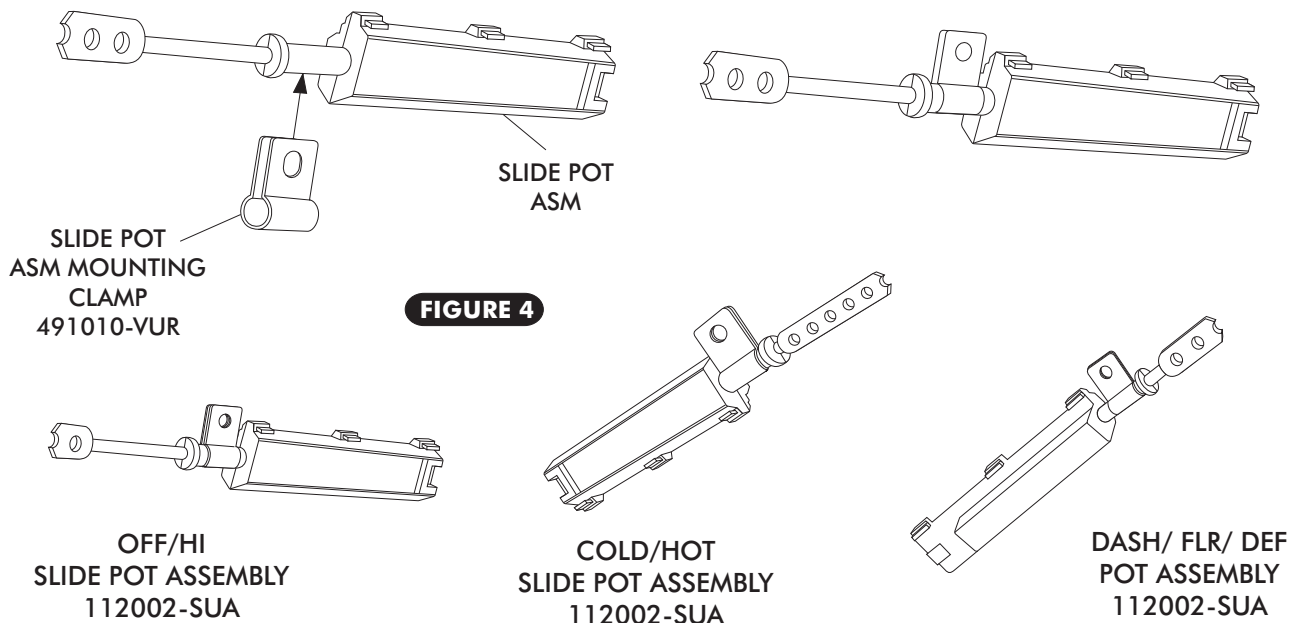

ORIENT SLIDE POT ASSEMBLIES AS SHOWN AND INSTALL MOUNTING CLAMPS AS SHOWN. (NOTE ORIENT CLAMPS IN RELATION TO THE (3) HOUSING SNAPS ON SLIDE POT ASSEMBLY.



SLIDE POT ASSEMBLY INSTALLATION

DASH/ FLR/ DEF SLIDE POT ASSEMBLY

TURN CONTROL PANEL OVER, BOTTOM SIDE FACING UP

- INSTALL SLIDE POT ASM ON THE DASH/FLR/ DEF LEVER. SEE FIGURE 5 BELOW.
- INSTALL SLIDE POT LEVER PUSH ROD ONTO OEM CABLE MOUNTING STUD ON LEVER. SEE FIGURE 5 BELOW.
- SECURE THE SLIDE POT ASM TO THE CONTROL PANEL USING THE OEM SCREW IN THE OEM CABLE CLAMP MOUNTING LOCATION. SEE FIGURE 5 BELOW.
- SINCE THE SLIDE POT ASSEMBLY CAN SLIDE BACK AND FORTH IN CLAMP BEFORE SCREW IS IT TIGHTENED POSITION SUCH THAT THE FLAT PART OF THE ROD IS AS CLOSE TO FLUSH AS POSSIBLE WITH THE END OF HOUSING AT THE LEVERS INNERMOST POSITION. SEE FIGURE 5 BELOW.
- SECURE SLIDE POT LEVER PUSH ROD ONTO OEM CABLE MOUNTING STUD USING 3/16 PUSH-ON RING AS SHOWN IN FIGURE 5 BELOW.

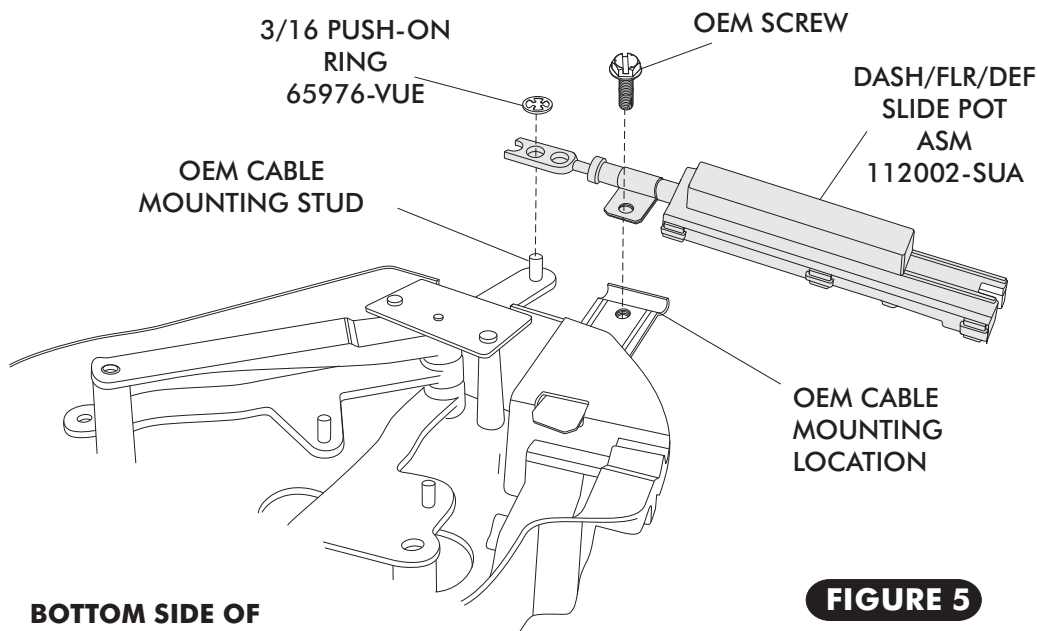
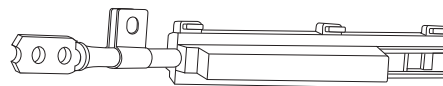
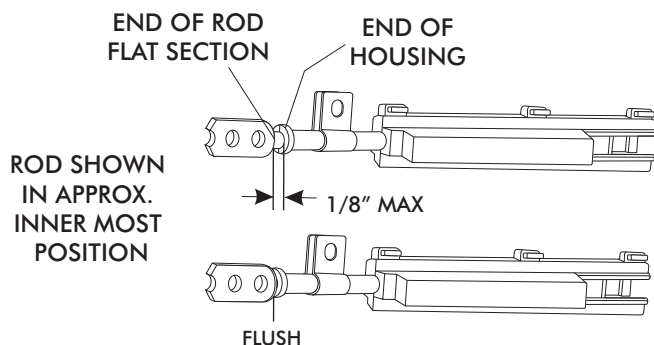

FIGURE 5



NOTE: DO NOT ALLOW ROD TO SEPARATE HOUSING WHEN ROD IS IN INNER MOST POSITION.



1967-68 CAMARO w/o AC CNTRL PNL

SLIDE POT ASSEMBLY INSTALLATION CONT.

- LOCATE THE CONTROL PANEL WIRE HARNESS AND PLUG THE CORRESPONDING WIRES INTO THE CORRECT SLIDE POT ASSEMBLY AS SHOWN IN FIGURE 5a BELOW.

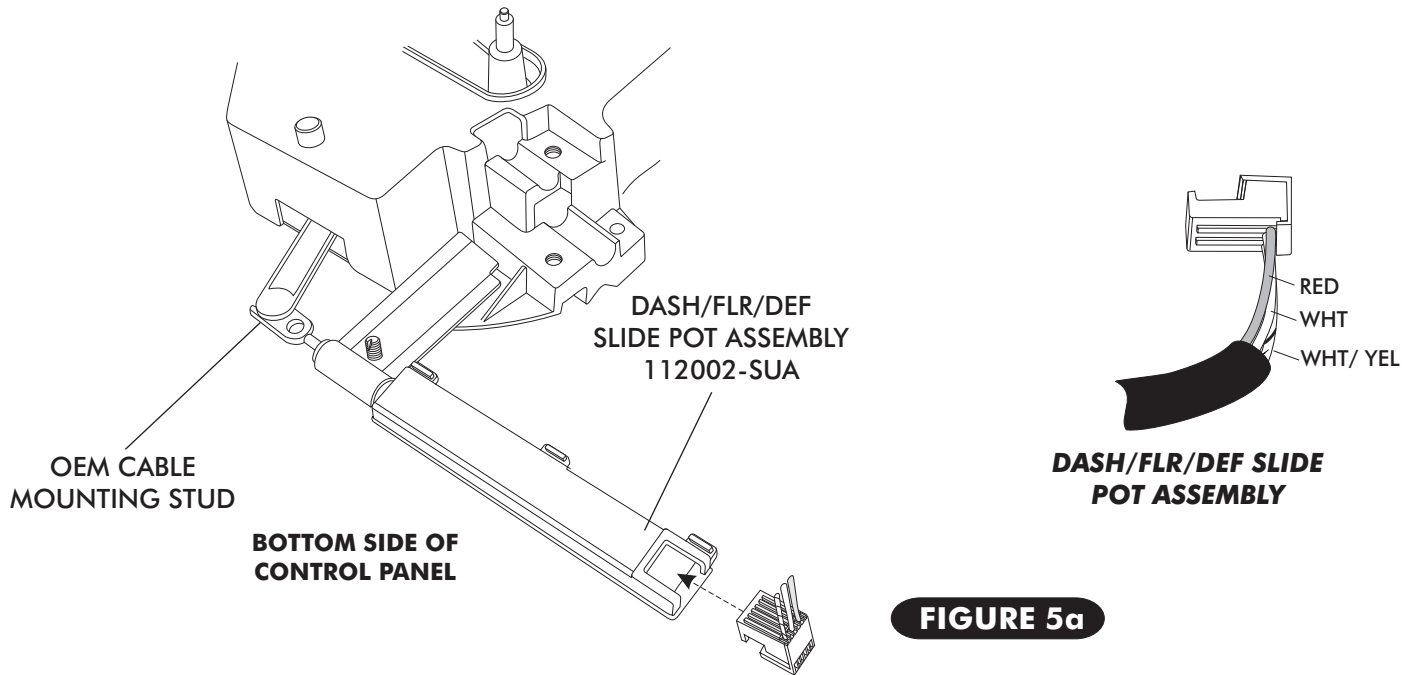

- ONCE WIRES ARE CORRECTLY PLUGGED INTO SLIDE POT ASSEMBLY, SECURE WIRES TO THE SLIDE POT ASSEMBLY USING TIE WRAPS (SUPPLIED). SEE FIGURE 5b BELOW. THE TIE WRAP MUST BE LOCATED BETWEEN THE END OF THE WIRE JACKET AND THE STEP IN THE SLIDE POT HOUSING FORCING A BEND IN EACH WIRE AS THEY PASS OVER THE STEP IN SLIDE POT HOUSING. HEAD OF TIE WRAP MUST FALL ON EDGE OF HOUSING AS SHOWN TO REMAIN TIGHT. ENSURE THAT THE TIE WRAPS ARE SNUG ENOUGH THAT THE WIRES CAN NOT MOVE. SEE FIGURE 5b.

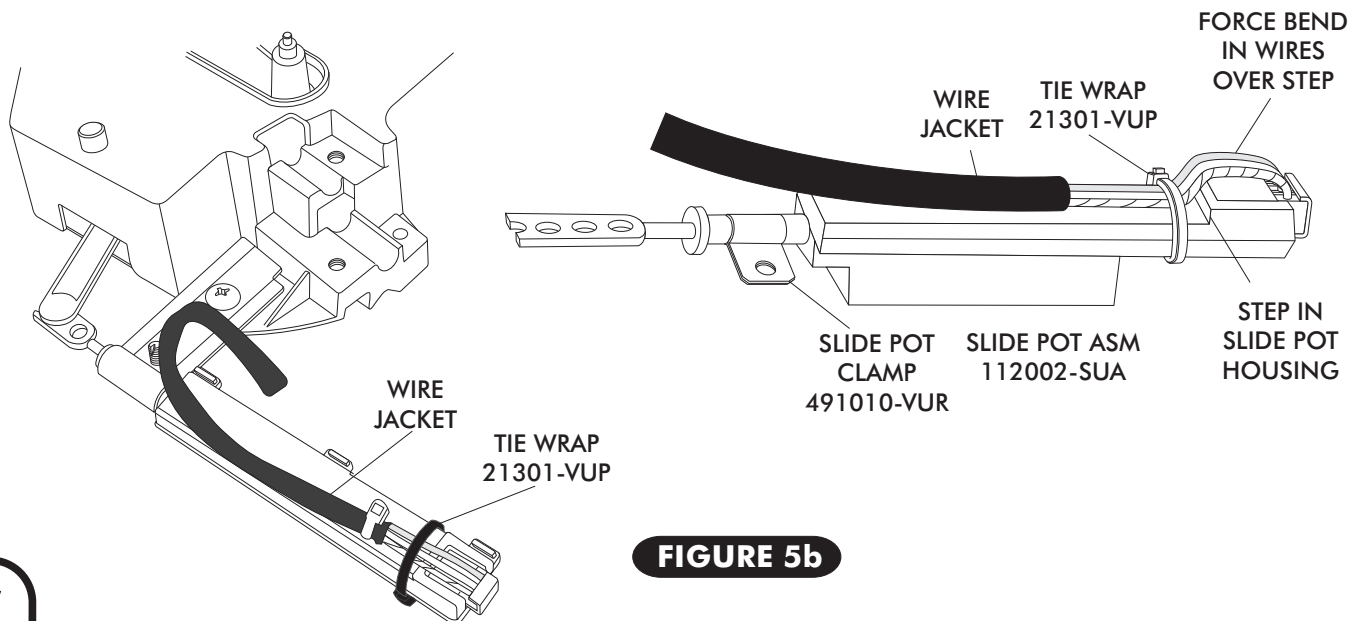



SLIDE POT ASSEMBLY INSTALLATION

COLD/HOT SLIDE POT ASSEMBLY

- INSTALL SLIDE POT ASM ON THE COLD/HOT LEVER. SEE FIGURE 6 BELOW.
- INSTALL SLIDE POT LEVER PUSH ROD ON TO OEM CABLE MOUNTING STUD ON LEVER. SEE FIGURE 6 BELOW.
- SECURE THE SLIDE POT ASM TO THE CONTROL PANEL USING THE OEM SCREW IN THE OEM CABLE CLAMP MOUNTING LOCATION. SEE FIGURE 6 BELOW.
- SECURE SLIDE POT LEVER PUSH ROD ON TO OEM CABLE MOUNTING STUD USING 3/16 PUSH-ON RING AS SHOWN IN FIGURE 6 BELOW.

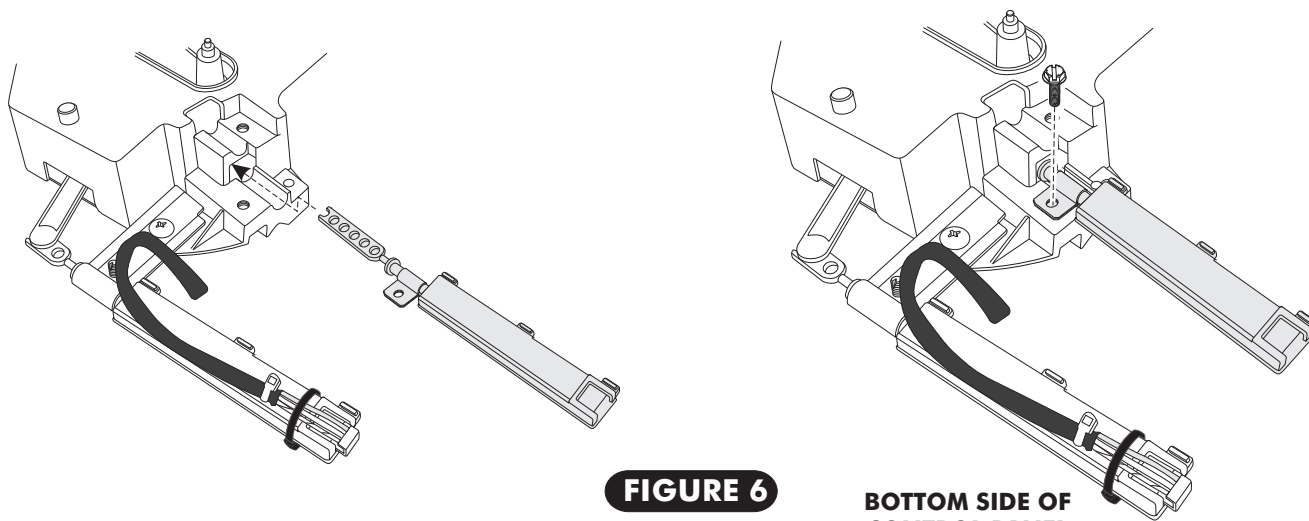

FIGURE 6

BOTTOM SIDE OF CONTROL PANEL

- LOCATE THE CONTROL PANEL WIRE HARNESS AND PLUG THE CORRESPONDING WIRES INTO THE CORRECT SLIDE POT ASSEMBLY AS SHOWN IN FIGURE 6a BELOW.

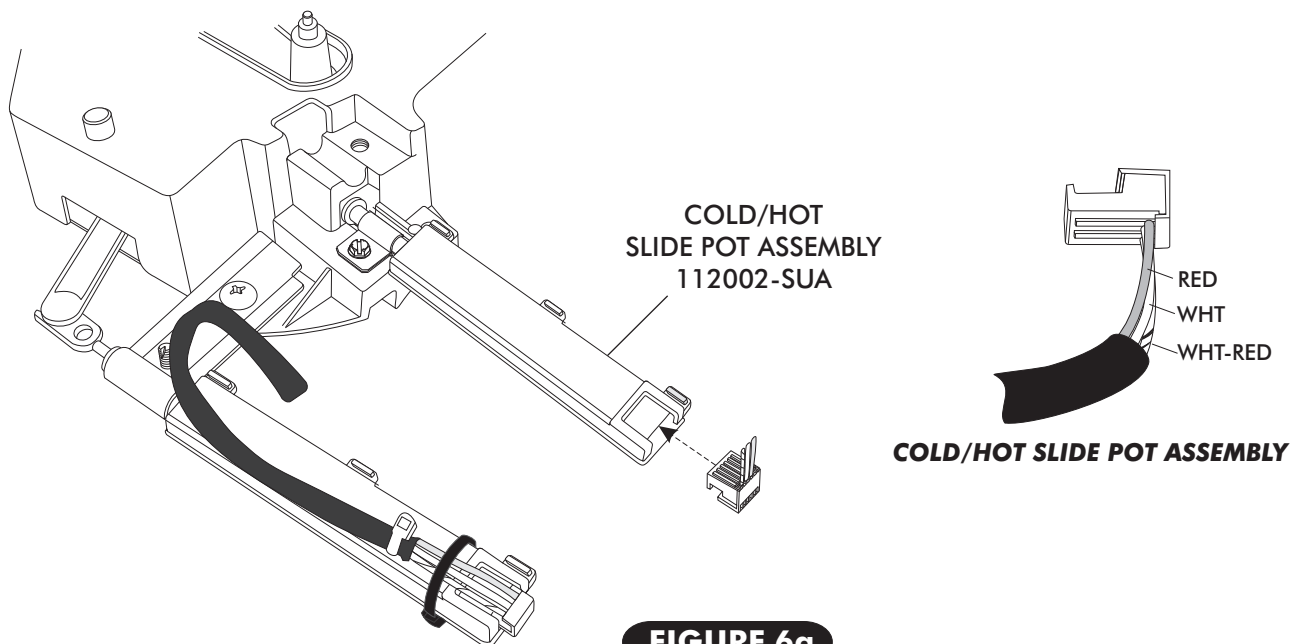

FIGURE 6a

COLD/HOT SLIDE POT ASSEMBLY



SLIDE POT ASSEMBLY INSTALLATION CONT.

- ONCE WIRES ARE CORRECTLY PLUGGED INTO SLIDE POT ASSEMBLY, SECURE WIRES TO THE SLIDE POT ASSEMBLY USING TIE WRAPS (SUPPLIED). SEE FIGURE 6b BELOW. THE TIE WRAP MUST BE LOCATED BETWEEN THE END OF THE WIRE JACKET AND THE STEP IN THE SLIDE POT HOUSING FORCING A BEND IN EACH WIRE AS THEY PASS OVER THE STEP IN SLIDE POT HOUSING. HEAD OF TIE WRAP MUST FALL ON EDGE OF HOUSING AS SHOWN TO REMAIN TIGHT. ENSURE THAT THE TIE WRAPS ARE SNUG ENOUGH THAT THE WIRES CAN NOT MOVE. SEE FIGURE 6b.

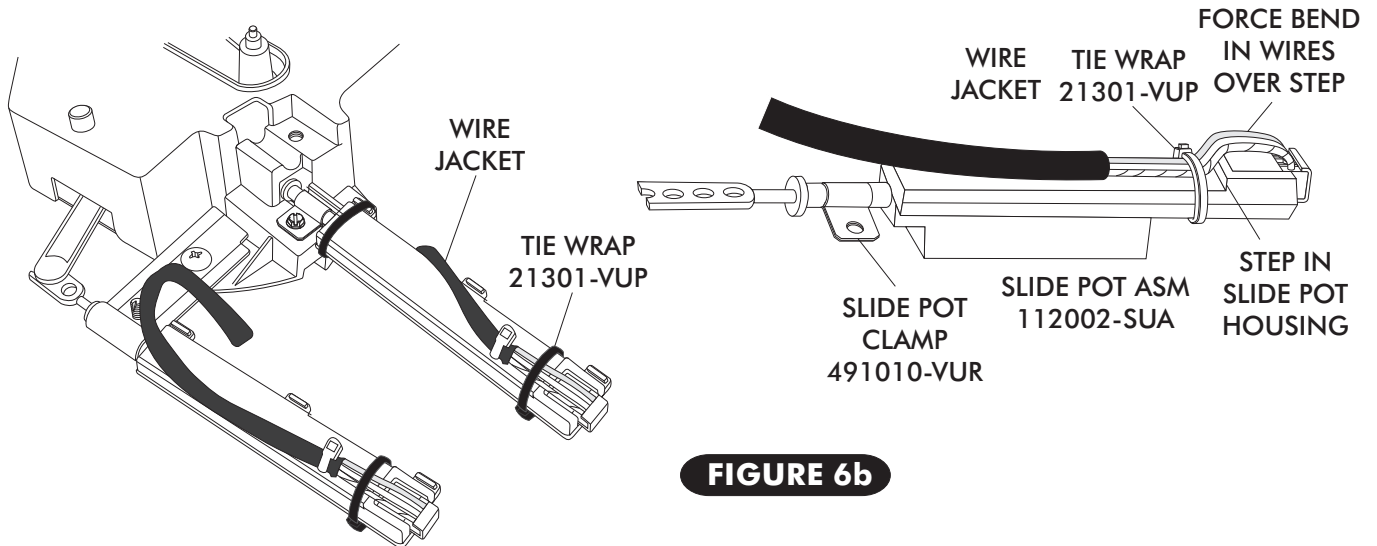

FIGURE 6b

SLIDE POT ASSEMBLY INSTALLATION

OFF/HI SLIDE POT ASSEMBLY

- INSTALL SLIDE POT ASM ON THE OFF/HI LEVER. SEE FIGURE 7 BELOW.
- INSTALL SLIDE POT LEVER PUSH ROD ON TO OEM CABLE MOUNTING STUD ON LEVER. SEE FIGURE 7 BELOW.
- SECURE THE SLIDE POT ASM TO THE CONTROL PANEL USING THE OEM SCREW IN THE OEM CABLE CLAMP MOUNTING LOCATION. SEE FIGURE 7 BELOW.
- SECURE SLIDE POT LEVER PUSH ROD ON TO OEM CABLE MOUNTING STUD USING 3/16 PUSH-ON RING AS SHOWN IN FIGURE 7 BELOW.

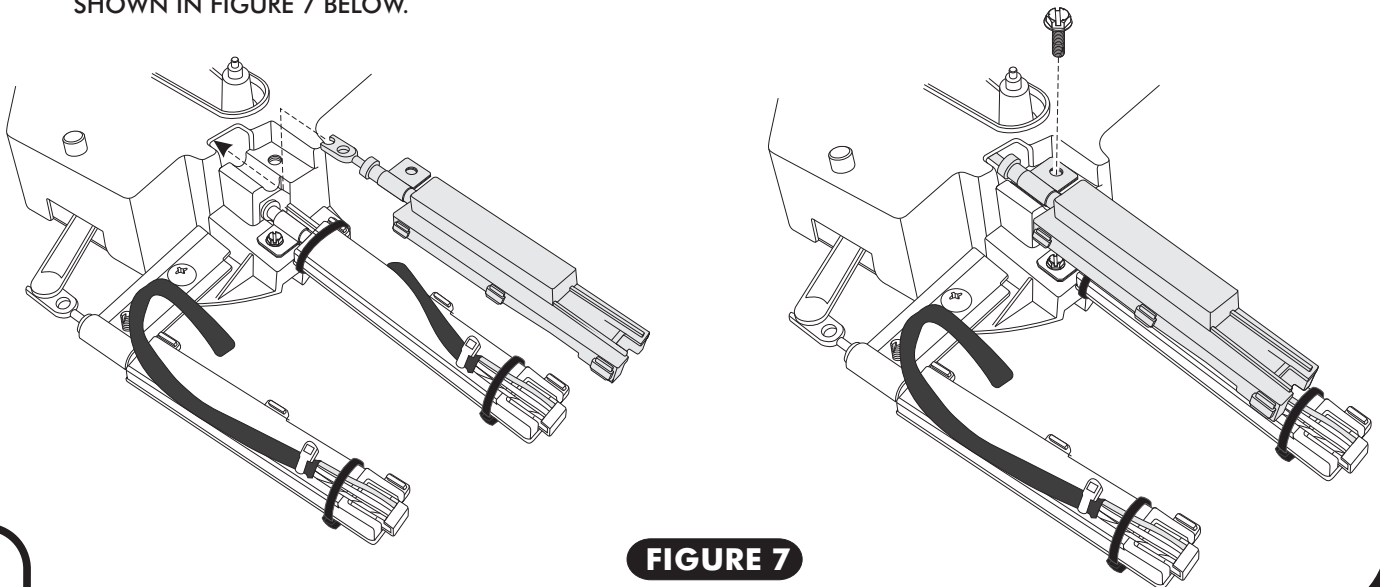
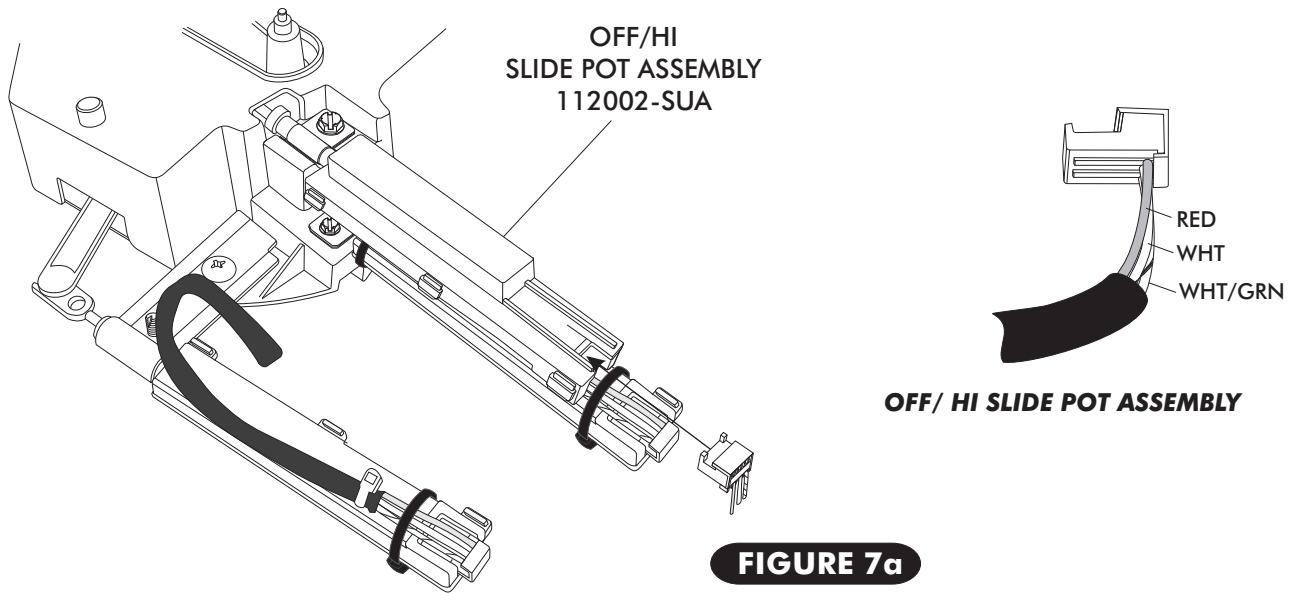

FIGURE 7



SLIDE POT ASSEMBLY INSTALLATION CONT.

- LOCATE THE CONTROL PANEL WIRE HARNESS AND PLUG THE CORRESPONDING WIRES INTO THE CORRECT SLIDE POT ASSEMBLY AS SHOWN IN FIGURE 7a BELOW.



- ONCE WIRES ARE CORRECTLY PLUGGED INTO SLIDE POT ASSEMBLY, SECURE WIRES TO THE SLIDE POT ASSEMBLY USING TIE WRAPS (SUPPLIED). SEE FIGURE 7b BELOW. THE TIE WRAP MUST BE LOCATED BETWEEN THE END OF THE WIRE JACKET AND THE STEP IN THE SLIDE POT HOUSING FORCING A BEND IN EACH WIRE AS THEY PASS OVER THE STEP IN SLIDE POT HOUSING. HEAD OF TIE WRAP MUST FALL ON EDGE OF HOUSING AS SHOWN TO REMAIN TIGHT. ENSURE THAT THE TIE WRAPS ARE SNUG ENOUGH THAT THE WIRES CAN NOT MOVE. SEE FIGURE 7b.

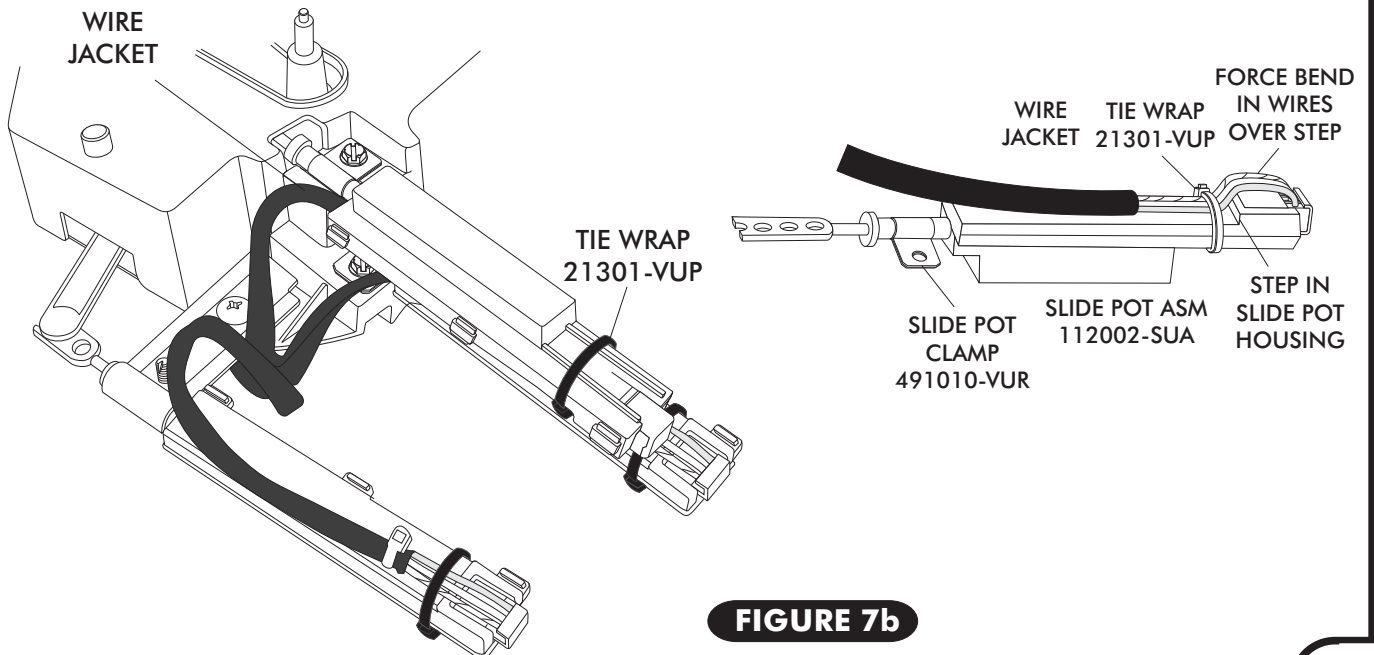



FINAL STEPS

- USING THE SUPPLIED TIE-WRAPS, TIE THE WIRES AND THE UNUSED WIRE TO THE CONTROL PANEL AS SHOWN IN FIGURE 8 BELOW. CONFIRM THAT WIRES ARE SECURE AND DO NOT INTERFERE WITH LEVER OPERATION OR SLIDE POT ASSEMBLY.
- INSTALL CONTROL PANEL IN DASH. TO EASE INSTALLATION, ROTATE CONTROL PANEL SLIGHTLY AND PASS THE SLIDE POT ASSEMBLIES THROUGH DASH OPENING FIRST. AS THE SLIDE POT ASSEMBLIES PASS THROUGH THE DASH OPENING ROTATE THE CONTROL PANEL BACK THE OPPOSITE DIRECTION TO FIT CONTROL PANEL IN DASH. **NOTE: MAKE SURE SLIDE POT ASSEMBLIES CLEAR DUCT HOSE BEHIND THE LEFT SIDE OF DASH OPENING. DO NOT FORCE THE CONTROL PANEL IN DASH, FORCING THE CONTROL PANEL IN DASH WILL DAMAGE SLIDE POT ASSEMBLIES AND/OR DUCT HOSE.**
- PLUG THE WIRING HARNESS INTO THE ECU MODULE ON SUB CASE. SEE FIGURE 8 BELOW.
- WIRE ACCORDING TO WIRING DIAGRAM ON PAGE 13.
- CALIBRATION PROCEDURE AND OPERATION INSTRUCTIONS:

CALIBRATING THE CONTROL PANEL WILL SET THE RANGE OF TRAVEL FOR THE SLIDE POTS CONNECTED TO THE OEM CONTROL PANEL LEVERS. PERFORMING THIS PROCEDURE WILL SET THE LIMITS OF THE SLIDE POTS AT THEIR HIGHEST AND LOWEST POINTS

LOCATE THE GRAY WIRE WITH AN UNUSED CONNECTOR IN THE WIRING HARNESS NEAR THE TWO CABLE HARNESS RELAYS. THIS WIRE IS LABELED PRGM ON THE WIRING DIAGRAM ON PAGE 13.

IT WILL BE NECESSARY TO GROUND THE GRAY WIRE FOR APPROXIMATELY FIVE SECONDS WHILE MOVING THE CONTROLS SO IT IS SOMETIMES HELPFUL TO ATTACH ONE END OF THE WHITE JUMPER WIRE TO THE VEHICLE'S GROUND (FOR EXAMPLE THE CHASSIS) AND HAVE THE OTHER END READY TO CONNECT TO THE GRAY PRGM WIRE WHEN THE PROCEDURE REQUIRES IT.

TO CALIBRATE THE CONTROL PANEL FOLLOW THE CALIBRATION PROCEDURES ON PAGE 12.

NOTE: TIE THE UNUSED WIRE TO THE CONTROL PANEL APPROXIMATELY AS SHOWN, ENSURE THAT THE WIRE DOES NOT INTERFERE WITH LEVERS OR SLIDE POT ASSEMBLIES.

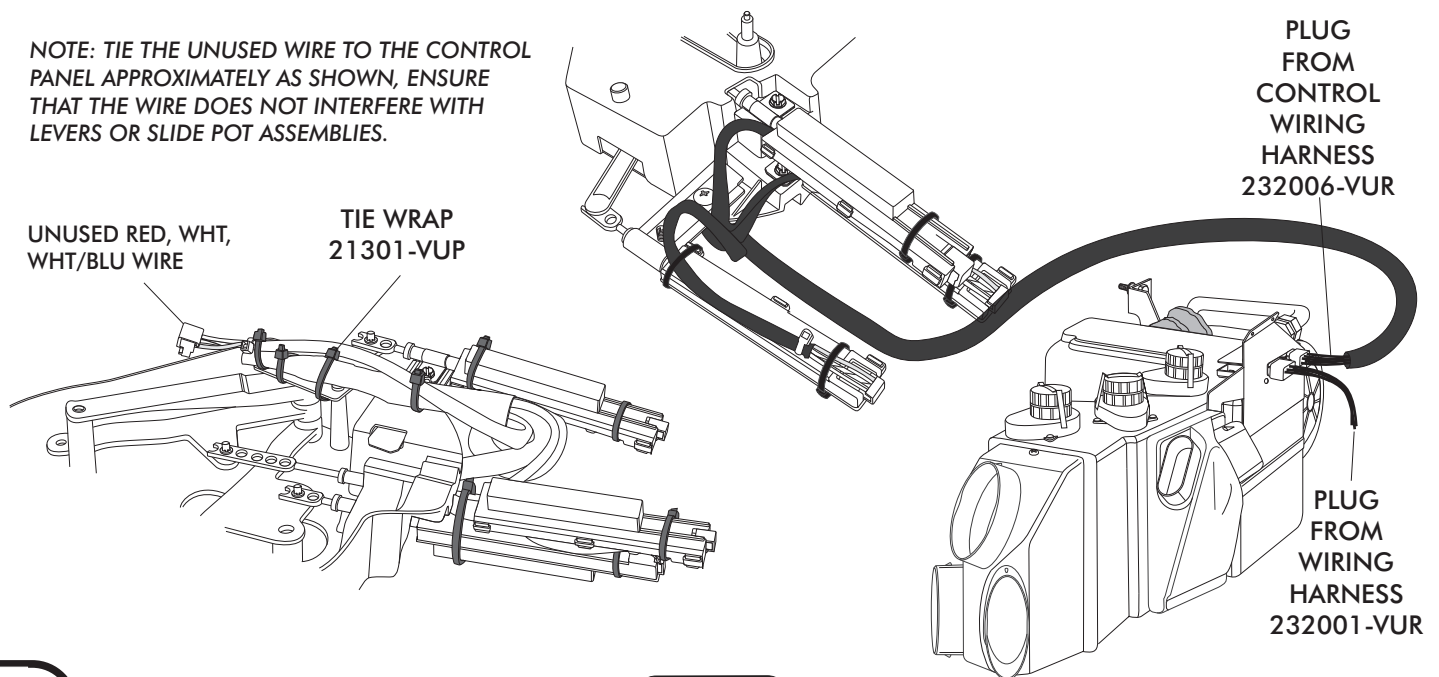

FIGURE 8



CONTROL PANEL CALIBRATION PROCEDURE

1. TURN THE IGNITION SWITCH ON (DO NOT START THE ENGINE)
2. CONNECT THE WHITE JUMPER WIRE TO VEHICLE'S GROUND (FOR EXAMPLE THE VEHICLE CHASSIS). ENSURE THAT THE GRAY WIRE IS NOT GROUNDED. DO NOT CONNECT JUMPER WIRE TO THE GRAY PRGM WIRE. SEE FIGURE A, BELOW.

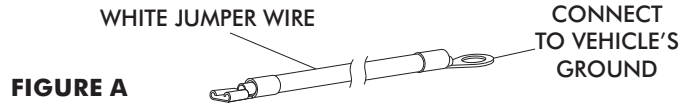

FIGURE A

3. MOVE ALL OF THE CONTROL LEVERS TO THEIR MAXIMUM POSITIONS, AS SHOWN IN FIGURE B, BELOW.



FIGURE B

4. GROUND THE GRAY WIRE BY CONNECTING THE GRAY PRGM WIRE & WHITE JUMPER WIRE FOR APPROXIMATELY 5 SECONDS (THE BLOWER WILL CHANGE SPEEDS WHEN STEP FOUR IS COMPLETE). SEE FIGURE C, BELOW.

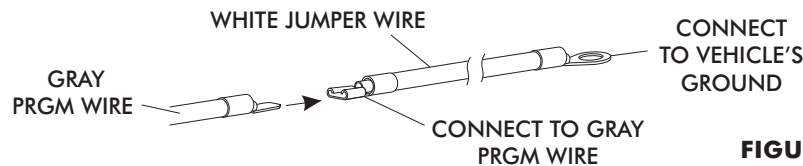

FIGURE C

5. LEAVING THE GRAY WIRE GROUNDED, MOVE ALL OF THE CONTROL LEVERS TO THEIR MINIMUM POSITIONS AS SHOWN IN FIGURE D BELOW.



FIGURE D

6. DISCONNECT THE GRAY WIRE FROM THE WHITE GROUND JUMPER WIRE (THE BLOWER WILL CHANGE SPEEDS WHEN STEP SIX IS COMPLETE). SEE FIGURE E, BELOW.

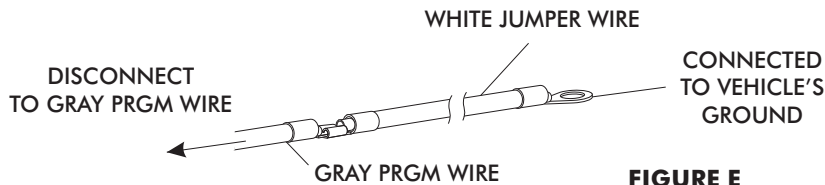

FIGURE E

7. START THE ENGINE AND TEST ALL OF THE CONTROLS TO ENSURE THAT THE INTENDED RESULTS WERE ACCOMPLISHED.
8. DISCONNECT THE WHITE JUMPER WIRE FROM VEHICLE'S GROUND.

NOTE: THIS PROCEDURE MAY BE REPEATED IF NECESSARY.

*** WHEN FINISHED, TAPE OVER PROGRAM WIRE CONNECTOR WITH ELECTRICAL TAPE TO PREVENT ACCIDENTAL CONTACT WITH CHASSIS GROUND.**



1967-68 CAMARO w/o AC CNTRL PNL

WIRING DIAGRAM

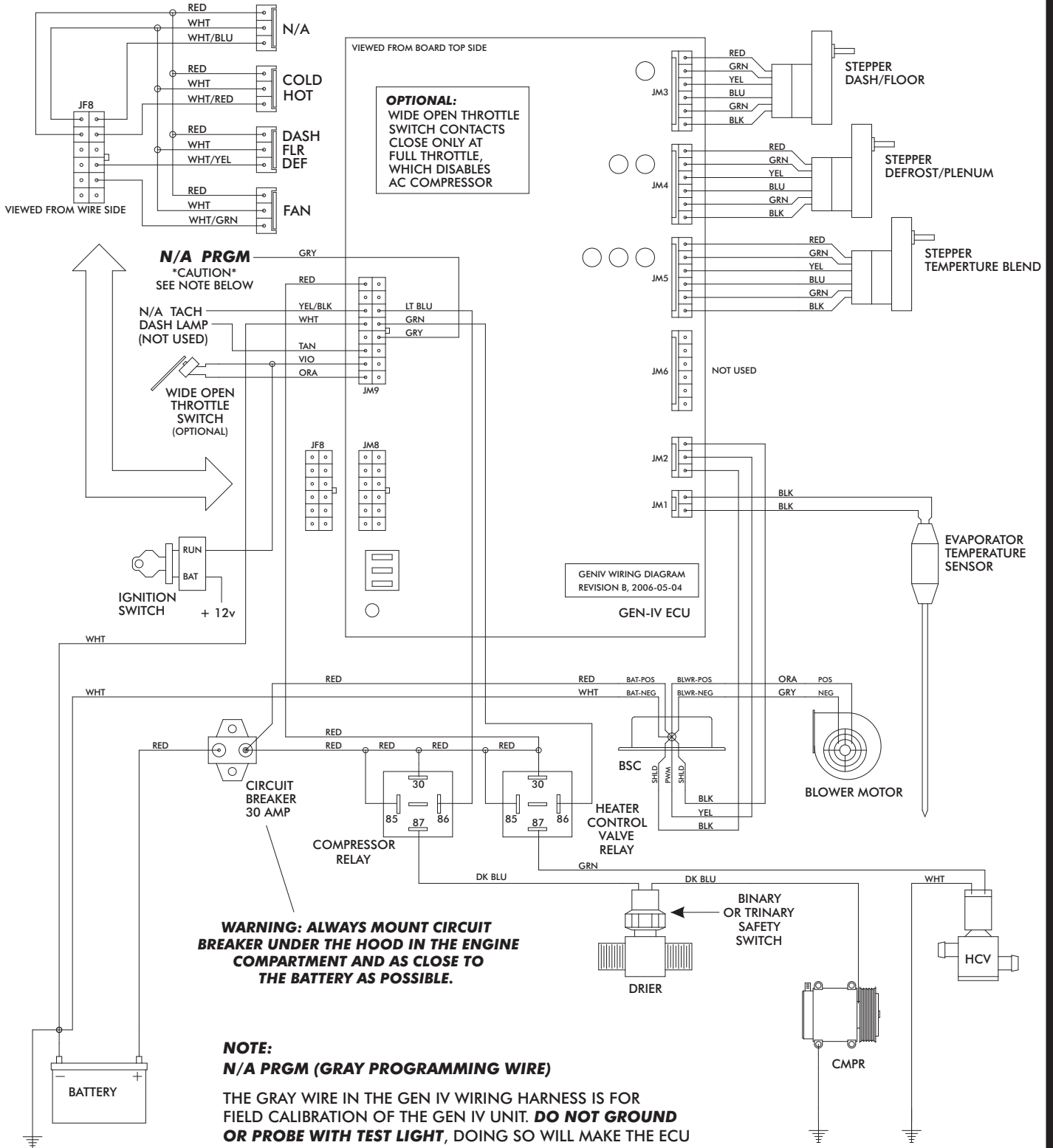

WARNING: ALWAYS MOUNT CIRCUIT BREAKER UNDER THE HOOD IN THE ENGINE COMPARTMENT AND AS CLOSE TO THE BATTERY AS POSSIBLE.

NOTE:
N/A PRGM (GRAY PROGRAMMING WIRE)

THE GRAY WIRE IN THE GEN IV WIRING HARNESS IS FOR FIELD CALIBRATION OF THE GEN IV UNIT. **DO NOT GROUND OR PROBE WITH TEST LIGHT**, DOING SO WILL MAKE THE ECU INOPERABLE AND THE ECU MUST BE RE-CALIBRATED. SEE CONTROL PANEL CALIBRATION PROCEDURE.

NOTE: = CHASSIS GROUND



1967-68 CAMARO w/o AC CNTRL PNL

OPERATION OF CONTROLS

NOTE:

WHEN BATTERY POWER IS FIRST CONNECTED TO THE ECU, THE COMPUTER GOES THROUGH AN INITIALIZATION SEQUENCE. THIS INITIALIZATION MAY TAKE UP TO 30 SECONDS. DURING INITIALIZATION THE BLOWER WILL NOT OPERATE, BUT THE DOORS INSIDE THE UNIT WILL BE OPERATING. A LOW BATTERY OR DISCONNECTING THE BATTERY MAY ALSO TRIGGER A RE-INITIALIZATION. DURING START UP, A LOW BATTERY MAY DROP BELOW 7 VOLTS, TRIGGERING RE-INITIALIZATION.

THE COLD LEVER TOGGLES BETWEEN COLD AND HOT MODES. FOR A/C MODE SLIDE THE COLD LEVER ALL THE WAY UP TO ENGAGE THE COMPRESSOR. SLIDE THE COLD KNOB LEVER DOWN TO SELECT DESIRED TEMPERATURE. FOR HEAT MODE SLIDE THE COLD LEVER ALL THE WAY DOWN TO DISENGAGE THE COMPRESSOR. SLIDE THE COLD LEVER UP TO TO SELECT DESIRED TEMPERATURE.

ALL SWITCHES ARE VARIABLE BETWEEN POSITIONS, SYSTEM WILL PERFORM A BLEND BETWEEN THE FUNCTIONS.

BLOWER SPEED

SYSTEM OFF



THERMOSTAT LEVER
MODE LEVER

BLOWER SPEED
THIS LEVER CONTROLS THE BLOWER SPEED, FROM OFF TO HI

THERMOSTAT LEVER
IN A/C MODE SLIDE THE THERMOSTAT LEVER ALL THE WAY LEFT TO THE COLD POSITION, FOR MAXIMUM COOLING (SLIDE LEVER LEFT OR RIGHT TO ADJUST DESIRED TEMPERATURE)

MODE LEVER
SLIDE THE LEVER TO THE "DASH" POSITION

A/C MODE



BLOWER SPEED
SLIDE LEVER RIGHT TO DESIRED BLOWER SPEED, FROM OFF TO HI

THERMOSTAT LEVER
IN A/C MODE SLIDE THE THERMOSTAT LEVER ALL THE WAY LEFT TO THE COLD POSITION TO ENGAGE COMPRESSOR, FOR MAXIMUM COOLING (SLIDE LEVER LEFT OR RIGHT TO ADJUST DESIRED TEMPERATURE)

MODE LEVER
SLIDE THE LEVER TO THE "DASH" POSITION

HEAT MODE



BLOWER SPEED
SLIDE LEVER RIGHT TO DESIRED BLOWER SPEED, FROM OFF TO HI

THERMOSTAT LEVER
IN HEAT MODE SLIDE THE THERMOSTAT LEVER ALL THE WAY RIGHT TO THE HOT POSITION, FOR MAXIMUM HEATING ((SLIDE LEVER LEFT OR RIGHT TO ADJUST DESIRED TEMPERATURE)

MODE LEVER
SLIDE THE LEVER TO THE "FLR" POSITION

DEFROST/ DE-FOG MODE



BLOWER SPEED
SLIDE LEVER RIGHT TO DESIRED BLOWER SPEED, FROM OFF TO HI

THERMOSTAT LEVER
IN DEF MODE SLIDE THE THERMOSTAT LEVER ALL THE WAY LEFT TO THE COLD POSITION TO ENGAGE COMPRESSOR. FOR MAXIMUM COOLING (SLIDE LEVER LEFT OR RIGHT TO ADJUST DESIRED TEMPERATURE)

MODE LEVER
SLIDE THE LEVER TO THE "DEF" POSITION



1967-68 CAMARO w/o AC CNTRL PNL

CONTROL KIT PACKING LIST

**CONTROL KIT
475168**

No.	QTY.	PART No.	DESCRIPTION	
1.	1	484168	67-68 CAMARO w/o AC CNTRL PNL MODE LABEL	_____
2.	3	112002-SUA	SLIDE POT ASM	_____
3.	1	232006-VUR	GEN IV UNIVERSAL CONTROL HARNESS (TYPE B)	_____
4.	3	65976-VUE	3/16" PUSH-ON RING	_____
5.	3	491010-VUR	SLIDE POT CLAMP	_____
6.	5	21301-VUP	4" TIE WRAP	_____
7.	1	231520	GROUND WIRE	_____
8.	4	18235-VUB	#8 x 1/2" PAN HEAD SCREW	_____

CHECKED BY: _____
 PACKED BY: _____
 DATE: _____

