

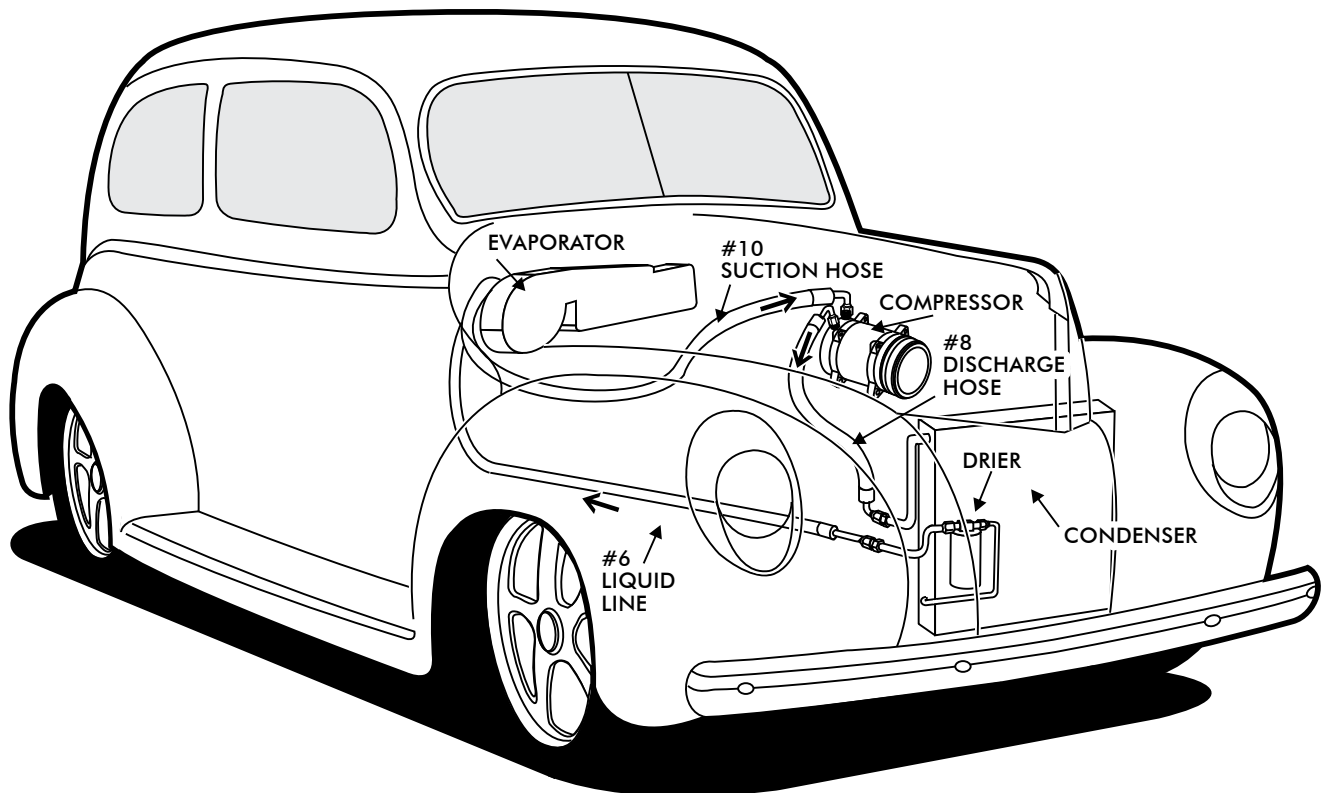

an ISO 9001:2008 Registered Company

# UNIVERSAL SUPER COOLER

HEAT/COOL  
61000-QUX-A/61000-VUX-A



18865 GOLL ST. - SAN ANTONIO, TX. - 78266 ph.210-654-7171 - fax 210-654-3113



## **TABLE OF CONTENTS**

### PAGES

1. COVER
2. TABLE OF CONTENTS
3. PACKING LIST
4. INFORMATION PAGE
5. PLANNING OVERVIEW
6. EVAPORATOR INSTALLATION
7. A/C LINES AND FITTINGS INSTALLATION
8. HOSE ROUTING ILLUSTRATION
9. HOSE ROUTING & O-RING LUBRICATION
10. HEATER HOSE INSTALLATION
11. OPERATION OF CONTROLS
12. WIRING DIAGRAM
13. ADJUSTING THERMOSTAT
14. EVAPORATOR KIT PACKING LIST



EVAPORATOR KIT  
 61000-QUX-A \_\_\_\_\_  
 61000-VUX-A \_\_\_\_\_

EVAPORATOR KIT PACKING LIST

No.	QTY.	PART No.	DESCRIPTION
1.	1	55256-VUE-A	EVAPORATOR w/ BLOWER SUB CASE
2.	1	63250-VUE	INSTALLATION KIT
3.	13	06250-VUE	2 1/2" DUCT HOSE
4.	1	63522-KUB	EVAPORATOR MNTG BRKT. KIT

**\*\* BEFORE BEGINNING INSTALLATION, OPEN ALL PACKAGES AND CHECK CONTENTS OF SHIPMENT. PLEASE REPORT ANY SHORTAGES DIRECTLY TO VINTAGE AIR WITHIN 15 DAYS. AFTER 15 DAYS, VINTAGE AIR WILL NOT BE RESPONSIBLE FOR MISSING OR DAMAGED ITEMS.**

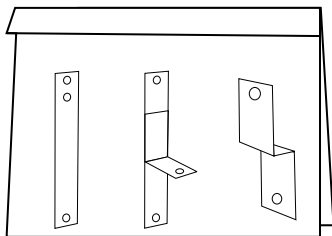
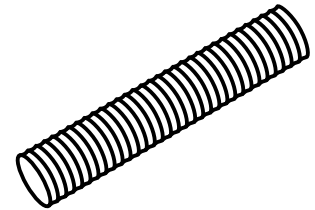
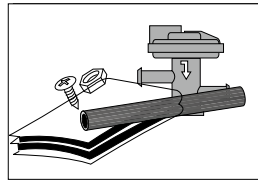
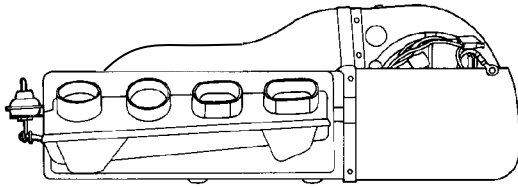



## UNIVERSAL SUPER COOLER HEAT/COOL

# IMPORTANT NOTICE-PLEASE READ

**FOR MAXIMUM SYSTEM PERFORMANCE VINTAGE AIR RECOMMENDS THE FOLLOWING:**

THIS KIT DOES NOT CONTAIN HEATER HOSE. YOU MUST PURCHASE 8 FEET OF 5/8" DIA. HEATER HOSE FROM VINTAGE AIR (31800-VUD) OR FROM YOUR LOCAL PARTS RETAILER.

### SAFETY SWITCHES:

A COMPRESSOR SAFETY SWITCH MUST BE INSTALLED ON EVERY A/C SYSTEM. A BINARY SWITCH (PART# 24679-VUS) DISENGAGES THE COMPRESSOR CLUTCH IN CASE OF EXTREME LOW PRESSURE CONDITIONS (REFRIGERANT LOSS) OR EXCESSIVELY HIGH HEAD PRESSURE (406 PSI.) TO PREVENT COMPRESSOR DAMAGE OR HOSE RUPTURE. A TRINARY SWITCH (PART# 24678-VUS) COMBINES HI/LOW PRESSURE PROTECTION WITH AN ELECTRIC FAN OPERATION SIGNAL AT 254 PSI. COMPRESSOR SAFETY SWITCHES ARE EXTREMELY IMPORTANT SINCE AN A/C SYSTEM RELIES ON REFRIGERANT TO CARRY LUBRICATION THROUGH THE SYSTEM.

### SERVICE INFO:

**ATTENTION:** SYSTEM COMPONENTS: THE COMPRESSOR, EVAPORATOR, CONDENSER & DRIER ARE CAPPED. CAPS MAY BE UNDER PRESSURE WITH DRY NITROGEN. BE CAREFUL REMOVING CAPS. DO NOT REMOVE CAPS PRIOR TO INSTALLATION. REMOVING CAPS PRIOR TO INSTALLATION WILL CAUSE COMPONENTS TO COLLECT MOISTURE AND LEAD TO PREMATURE FAILURE AND REDUCED PERFORMANCE.

EVACUATE THE SYSTEM FOR 35-45 MINUTES WITH SYSTEM COMPONENTS (DRIER, COMPRESSOR, EVAPORATOR, AND CONDENSER) AT A TEMPERATURE OF AT LEAST 85° F. ON A COOL DAY. THE COMPONENTS CAN BE HEATED WITH A HEAT GUN OR BY RUNNING THE ENGINE WITH THE HEATER ON BEFORE EVACUATING. LEAK CHECK AND CHARGE TO SPECIFICATIONS.

**VINTAGE AIR SYSTEMS ARE DESIGNED TO OPERATE WITH R134a REFRIGERANT ONLY! USE OF ANY OTHER REFRIGERANTS IS A FIRE HAZARD AND COULD DAMAGE EITHER YOUR AIR CONDITIONING SYSTEM OR YOUR VEHICLE.**

**USE OF ANY OTHER REFRIGERANTS WILL VOID ALL WARRANTIES OF THE AIR CONDITIONING SYSTEM AND COMPONENTS. USE OF THE PROPER TYPE AND AMOUNT OF REFRIGERANT IS CRITICAL TO PROPER SYSTEM OPERATION. VINTAGE AIR RECOMMENDS OUR SYSTEMS BE CHARGED BY WEIGHT WITH A QUALITY CHARGING STATION OR SCALE.**

### REFRIGERANT CAPACITIES FOR VINTAGE AIR SYSTEMS

(FOR OTHER SYSTEMS, CONSULT MANUFACTURER GUIDELINES)

#### **R134a SYSTEM**

CHARGE WITH 1.8 lbs.  
(1 lbs. 12 oz) OF REFRIGERANT

**LUBRICANT CAPACITIES:** NEW COMPRESSOR - NO ADDITIONAL OIL NEEDED  
USED COMPRESSOR - CONSULT VINTAGE AIR



## PLANNING OVERVIEW

EVERY VEHICLE IS A LITTLE DIFFERENT, DEPENDING ON THE:

1. TYPE OF VEHICLE/ENGINE AND LOCATION OF ENGINE.
2. TYPE OF AIR CONDITIONING EQUIPMENT USED.
3. OWNER'S PREFERENCES.

THERE ARE MANY FACTORS THAT GO INTO MAKING EACH AIR CONDITIONING INSTALLATION DIFFERENT. USUALLY, ALL OF THE ABOVE DECISIONS ARE MADE BEFORE ANY CONSIDERATION IS GIVEN TO THE AIR CONDITIONING INSTALLATION. THE A/C SYSTEM IS THEN TAILORED TO FIT YOUR PARTICULAR APPLICATION.

THE MOUNTING LOCATION OF THE EVAPORATOR UNIT IS DETERMINED IN PART BY THE SPACE AVAILABLE FOR THE HOSE ROUTING. THE COMPONENTS USED IN THE HOSE ROUTING PROCESS (I.E. BULKHEAD PLATES, FITTINGS, AND GROMMETS, ETC.) WILL ALSO INFLUENCE THE LOCATION OF THE EVAPORATOR UNIT. WHEN PLANNING YOUR HOSE ROUTING, YOU MUST INSTALL THE MAJOR COMPONENT PARTS. MOUNT THE COMPRESSOR, CONDENSER AND DRIER. THE EVAPORATOR MUST BE TEMPORARILY HELD IN POSITION UNDER THE DASH. FINAL MOUNTING OF THE EVAPORATOR TO THE FIREWALL SHOULD NOT BE DONE, UNTIL YOU HAVE VERIFIED THAT ALL HOSES ATTACHING TO THE EVAPORATOR WILL EXIT THE FIREWALL AND/OR KICK PANEL AS PLANNED. THE HOSES MUST BE RUN EXACTLY THE WAY THEY WILL BE WHEN FINISHED, BEFORE CUTTING THEM TO LENGTH.

DUCT HOSE ROUTING AND A/C VENT LOCATIONS SHOULD ALSO BE GIVEN CAREFUL CONSIDERATION BEFORE FINAL MOUNTING POSITION OF THE EVAPORATOR IS SELECTED.

THE VINTAGE AIR UNIVERSAL SUPER COOLER UNIT WAS DESIGNED FOR STREET RODS, CUSTOM CARS, AND TRUCKS. THE EVAPORATOR UNIT IS DESIGNED TO MOUNT BEHIND THE DASH.

READ THE INSTALLATION INSTRUCTIONS COMPLETELY, AND FAMILIARIZE YOURSELF WITH ALL THE PARTS AND ILLUSTRATIONS.

THE INSTALLATION OF THIS UNIT VARIES, ACCORDING TO THE BODY MANUFACTURER OR MODIFICATIONS TO THE ORIGINAL BODY. THE COWL VENT MAY REMAIN OPERATIONAL. TAKE YOUR TIME, AND DOUBLE CHECK BEFORE DRILLING OR CUTTING.

BEFORE BEGINNING, REMOVE COWL VENT HANDLE AND GLOVE BOX TO EASE INSTALLATION. IF THE DASH IS EASILY REMOVABLE, REMOVE IT NOW. CHECK FOR, AND FILL IN ANY HOLES IN THE FIREWALL AND FLOOR. INSULATE AND SEAL FIREWALL, FLOOR, DOOR PANELS, AND HEADLINER TO REDUCE THE AMOUNT OF HEAT ENTERING THE CAR. FIGURE 1 SHOWS THE GENERAL LOCATION OF THE EVAPORATOR. LOCATIONS WILL VARY.

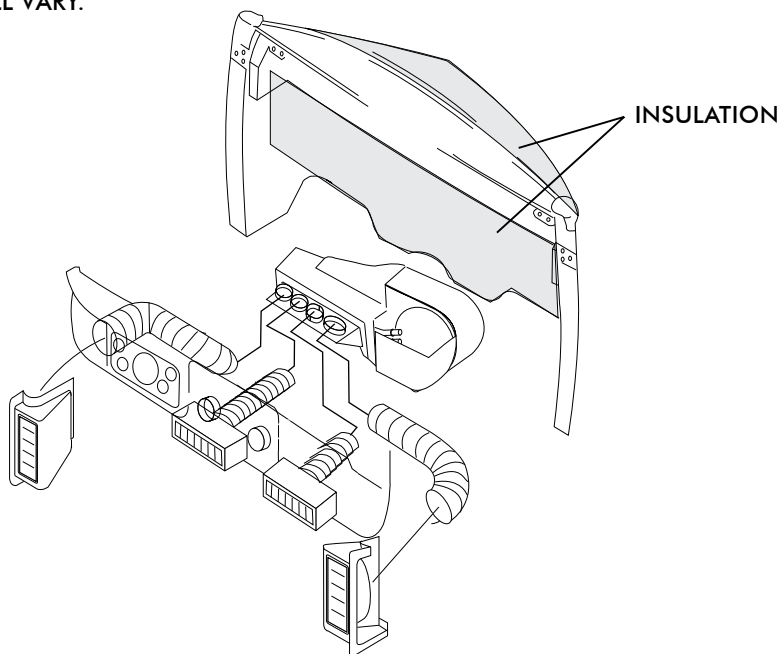

**FIGURE 1**



## INSTALLATION STEPS

1. MOUNT COMPRESSOR ON ENGINE. FOLLOW THE INSTRUCTIONS INCLUDED WITH COMPRESSOR BRACKET KIT.
2. MOUNT CONDENSER IN PROPER LOCATION.
3. BRACKETS ARE FURNISHED TO MOUNT THE EVAPORATOR CASE. ATTACH TO FIREWALL AS SHOWN IN FIGURE 2.
4. THE COWL VENT HANDLE WILL WORK IF MOVED TO THE SIDE. YOU CAN ALSO CONVERT TO ELECTRIC OR CABLE OPERATION. IF YOU CLOSE OFF THE COWL VENT, THE UNIT WILL FIT HIGHER IN THE CAR. NOTE: TO MOUNT UNIT HIGHER, SIMPLY DETERMINE THE NEW LOCATION, MARK AND RE-DRILL THE BRACKET TO FIT AS DESCRIBED IN STEP 6 - FIGURE 2.
5. WHEN FITTING THE EVAPORATOR:

- A. REMOVE BLOWER MOTOR COVER.
- B. ATTACH REAR BRACKET TO THE EVAPORATOR, USING (2) 1/4"-20 x 1/2" BOLTS.
- C. TEST FIT REFRIGERATION FITTINGS WITH HOSES FOR PROPER CLEARANCE INSIDE THE CAR. REFER TO HOSE ROUTING INSTRUCTIONS ON PAGE 8.

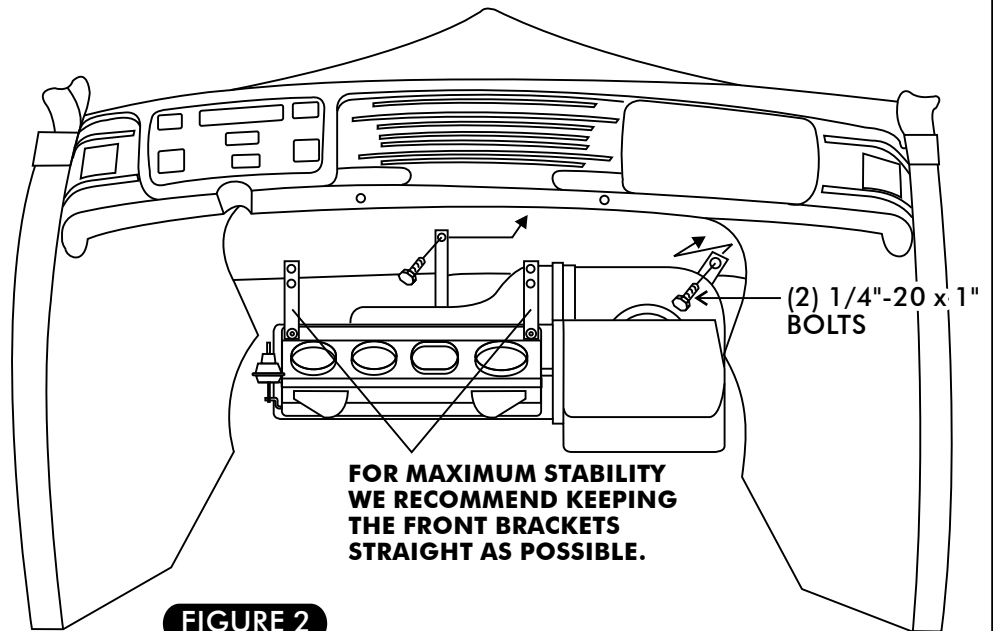

6. HAVE A HELPER HOLD THE UNIT UP AS HIGH AS POSSIBLE, WITH BLOWER HOUSING AGAINST PASSENGER SIDE KICK PANEL. LOCATE THE BRACKET ON THE TOP RIGHT OF THE BLOWER HOUSING. SCRIBE THRU THE 1/4" HOLE IN THE BRACKET TO MARK THE FIREWALL. CHECK TO SEE IF THE LOCATION YOU MARKED LOOKS CORRECT AND WILL CLEAR OBSTRUCTIONS ON BOTH SIDES OF THE FIREWALL. IF SO, DRILL A 9/32" HOLE IN THE FIREWALL. ATTACH THE EVAPORATOR TO THE FIREWALL BY THE BLOWER MOTOR BRACKET WITH A 1/4"-20 x 1" BOLT AND NUT. LEVEL THE EVAPORATOR UNIT, AND USE THE 1/4" HOLE IN THE EVAPORATOR REAR BRACKET AS A GUIDE, MARK AND DRILL A 9/32" HOLE IN FIREWALL. ATTACH THIS BRACKET TO THE FIREWALL WITH A 1/4"-20 x 1" BOLT. THIS WILL LOCATE THE EVAPORATOR HORIZONTALLY. NOW SECURE THE FRONT EVAPORATOR SUPPORT STRAP TO THE UNIT WITH THE SUPPLIED 1/4"-20 x 1/2" BOLT. THIS SUPPORT BRACKET WILL ATTACH TO THE DASH MOUNT HEADER. WITH THE UNIT HELD IN PLACE (PLUMB AND LEVEL), MARK THRU THE 3/16" HOLE AT THE TOP OF THE BRACKET TO THE SHEET METAL HEADER. MAKE SURE THAT THE SPOT MARKED WILL PROVIDE A GOOD MOUNTING LOCATION FOR THIS BRACKET. DRILL 1/8" MOUNTING HOLE. SECURE THE MOUNT STRAP TO THE COWL HEADER AS SHOWN IN FIGURE 2 WITH (2) #8 x 1/2" SCREWS (SUPPLIED).



7. PUSH THE 5/16" I.D. HOSE ONTO THE STRAIGHT #6 FITTING. (SEE HOSE ROUTING ILLUSTRATION ON PG.8). INSTALL THE FITTING ONTO THE EXPANSION VALVE (FINGER TIGHT). PUSH THE 1/2" I.D. HOSE ONTO THE STRAIGHT #10 FITTING , AND INSTALL THE FITTING ONTO THE #10 LINE ON THE EVAPORATOR. (SEE HOSE ROUTING ILLUSTRATION PG. 8).
  8. AT THIS TIME, TRY TO DETERMINE WHERE YOU WANT YOUR LINES TO GO THROUGH THE FIREWALL. MOVE THE HOSES TO THAT POINT. HOLD THE FITTINGS UP TO THEIR RESPECTIVE HOSES, AND DETERMINE IF THE HOSES WILL CONFORM TO THE LOCATION FOR THE BULKHEAD FITTINGS OR OPTIONAL BULK-HEAD PLATE (VINTAGE AIR PART #34215-VUQ OR 34218-VUQ). THE 1/2" HOSE IS HARD TO BEND AT A SHARP ANGLE, AND THE FITTINGS TAKE UP A CERTAIN AMOUNT OF SPACE. BEFORE YOU DRILL HOLES IN YOUR FIREWALL, MAKE SURE THAT YOU CAN MAKE THE HOSES FIT WHERE YOU HAVE PLANNED. THE ENGINE COMPARTMENT APPEARANCE IS A CONSIDERATION WHEN CHOOSING THIS LOCATION.
  9. WHEN YOU HAVE DECIDED WHERE YOU WANT TO PLACE YOUR BULKHEAD FITTINGS, MARK THESE POINTS WITH A GREASE PENCIL, AND MAKE A TEMPLATE FROM THE INSIDE LOCATING WHERE THE HOLES WILL BE CUT. WITH THIS TEMPLATE, LOCATE THE SAME POINTS ON THE OUTSIDE OF THE FIREWALL. MARK THESE POINTS WITH A GREASE PENCIL.
  10. DETERMINE THE BEST LOCATION FOR THE DRIER THAT WILL ALLOW ADEQUATE ROOM FOR THE HOSE AND FITTINGS THAT CONNECT THE DRIER TO THE BULKHEAD FITTING.
  11. MOUNT THE DRIER. (KEEP THE DRIER CAPPED AS MUCH AS POSSIBLE, AND IF YOU MUST SCREW THE FITTING TO THE DRIER, TAPE IT CLOSED).
- NOTE: THE DRIER IS USUALLY MOUNTED WHERE YOU HAVE ROOM FOR IT. JUST REMEMBER TO MOUNT IT IN THE COOLEST SPOT POSSIBLE AND VERTICALLY SO THE SIGHT GLASS IS DIRECTLY ON TOP. (NOT NEXT TO THE EXHAUST MANIFOLD). IT CAN BE MOUNTED INSIDE THE VEHICLE AS WELL.**
12. AT THIS POINT, CUT HOLES FOR BULKHEAD FITTINGS, AND INSTALL THEM.
  13. USING THE HOSE ROUTING ILLUSTRATION ON PG. 8 AS A GUIDE, ROUTE REMAINING A/C LINES, AND CUT TO LENGTH.
  14. INSTALL A/C VENTS THAT WILL BE USED AT THIS TIME.
  15. CENTER OUTLET: YOU MAY USE THE CENTER PANEL FURNISHED, OR YOU CAN MOUNT THE VENTS IN DASH. IF YOU USE THE CONTROL PANEL, THE TOP MOUNTING LIP SHOULD BE BACK 1/4" x 1/2" FROM LOWER LEADING EDGE OF DASH. LOCATE THE 2 1/2" I.D. HOSE, AND ROUTE FROM THE DASH VENTS TO THE EVAPORATOR.
  16. AT THIS TIME, YOU SHOULD HAVE THE REFRIGERATION HOSES CUT TO THEIR PROPER LENGTH. **PAY CLOSE ATTENTION TO THE ORIENTATION OF ANY HOSE WITH TWO ANGLED FITTINGS.** ANY HOSE WITH TWO ANGLED FITTINGS MUST BE MARKED FROM THE HOSE TO THE FITTINGS TO ASSURE THEY WILL REMAIN IN THIS POSITION AFTER CRIMPING. THE RUBBER HOSE IS ONLY CAPABLE OF A MINIMAL AMOUNT OF TWIST TO AID ALIGNMENT.
  17. REMOVE HOSES AND CRIMP ENDS. IF YOU DO NOT HAVE ACCESS TO THE PROPER EQUIPMENT, YOU MUST TAKE THEM TO A QUALIFIED A/C SERVICE CENTER FOR CRIMPING. (SEE CRIMPING INSTRUCTIONS SUPPLIED WITH THE HOSE KIT).
  18. WITH THE EVAPORATOR TRIAL FIT COMPLETE, YOU MAY REMOVE UNIT AND LOWER IN VEHICLE.
  19. AFTER CRIMPING HOSES, LOCATE THE #6 A/C HOSE WITH THE STRAIGHT FITTING. LUBRICATE A #6 A/C O-RING AND THE THREADS ON THE FITTING, AND INSTALL ON THE EXPANSION VALVE. TIGHTEN CAREFULLY. REFER TO FIGURES 3 & 3A, PAGE 9.
  20. LOCATE THE #10 A/C HOSE WITH THE STRAIGHT FITTING. LUBRICATE A #10 O-RING AND THE THREADS ON THE FITTING, AND INSTALL ON THE #10 LINE OF THE EVAPORATOR. TIGHTEN CAREFULLY. REFER TO FIGURES 3 & 3A, PAGE 9.
  21. WRAP THE #10 FITTING WITH PRESS TAPE, AND COVER ALL EXPOSED METAL SURFACES. (DO NOT WRAP THE #6 HOSE, FITTING, OR THE HEATER CORE TUBES). SEE FIGURE 3, PAGE 9.



# TYPICAL HOSE ROUTING DIAGRAM

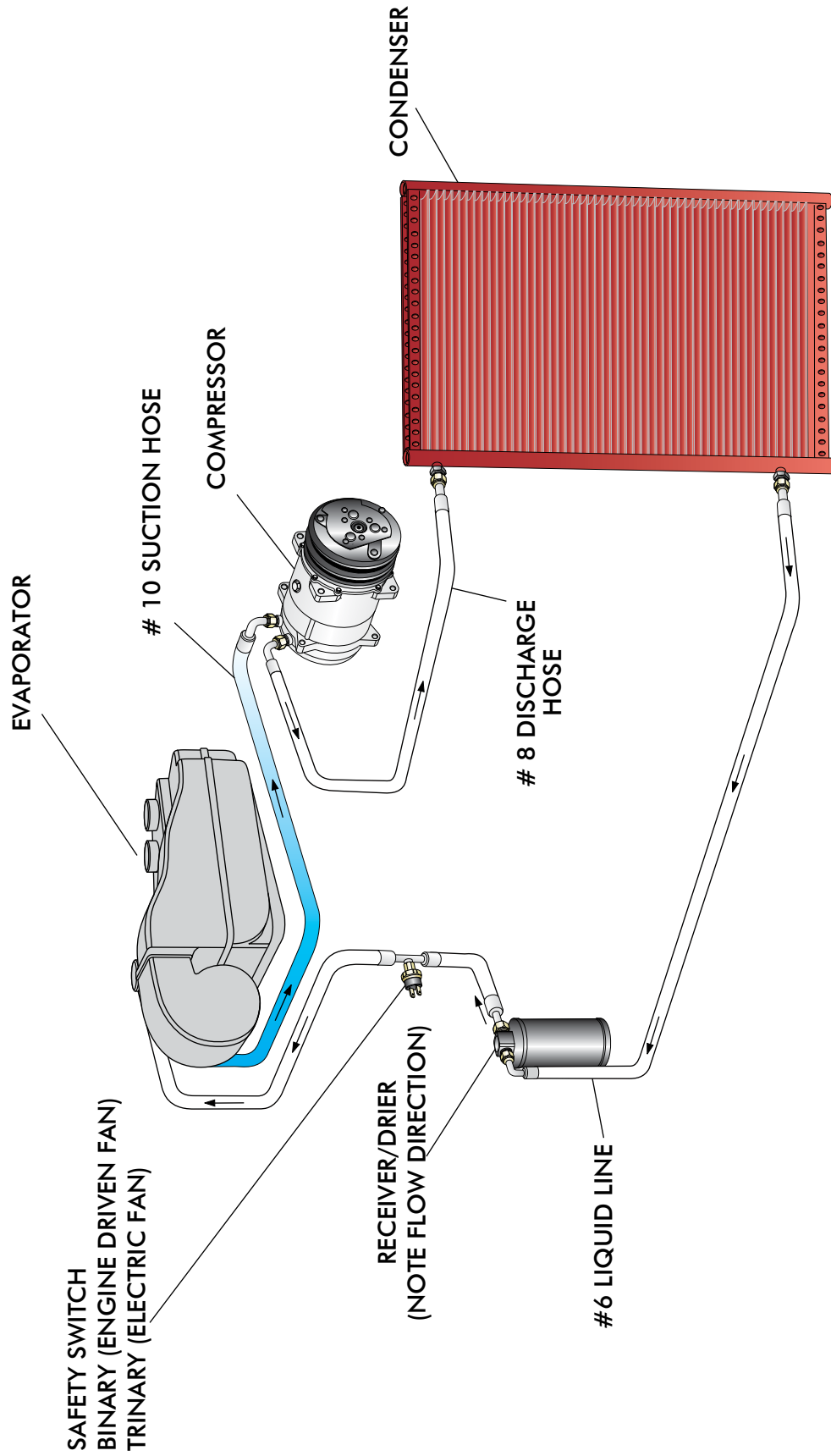

DIRECTION OF REFRIGERANT FLOW INDICATED BY ARROWS



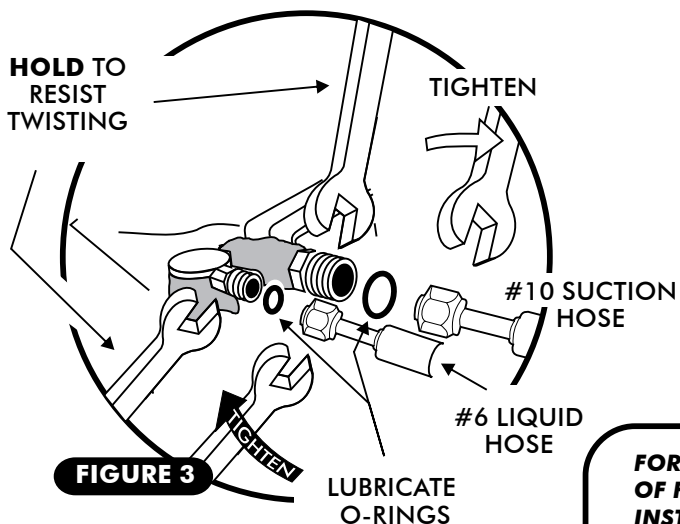

**FIGURE 3**

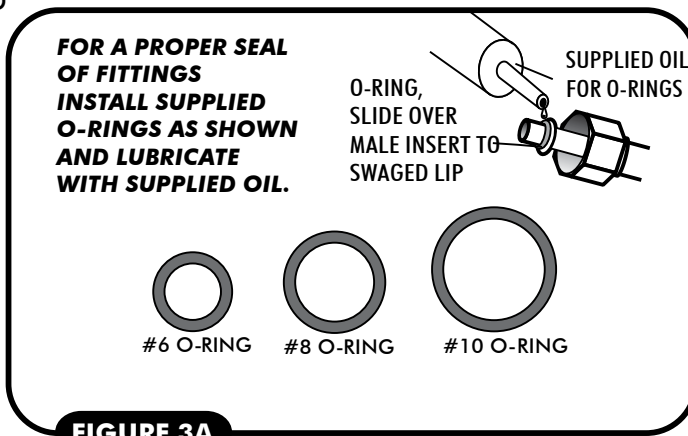

**FIGURE 3A**

22. IF USING A CONTROL PANEL WITH A THERMOSTAT MOUNTED ON THE CONTROL PANEL, INSERT THE CAPILLARY TUBE INTO THE COIL THROUGH THE LOCATION STICKER LOCATED ON TOP OF THE EVAPORATOR, TO A DEPTH OF 4½" (SEE PAGE 13). WITH REFRIGERATION HOSES AND DUCT HOSES ON THE UNIT, LIFT IT IN PLACE. MAKE SURE THAT THE FIREWALL FITTINGS ARE ACCESSIBLE WITH THE UNIT IN PLACE. IF NOT, TIGHTEN ALL REFRIGERATION FITTINGS INSIDE THE CAR NOW, WHILE YOU CAN REACH THEM. LIFT THE UNIT INTO PLACE, AND TIGHTEN THE BRACKET BOLTS TO SECURE TO THE EVAPORATOR.
23. ROUTE HEATER HOSES (REFER TO HEATER HOSE ROUTING INSTRUCTIONS, PG. 10).
24. WITH YOUR UNIT IN PLACE, STRETCH THE DUCT HOSE TIGHTLY TO THE DASH VENT, AND RECHECK THE LENGTH. TRIM TO ENSURE THAT THE HOSE IS TAUT, WITH A MINIMUM OF KINKS OR SHARP BENDS IN THE HOSE. THIS WILL ENSURE MAXIMUM AIRFLOW.
25. MAKE ELECTRICAL CONNECTIONS, ACCORDING TO THE DIAGRAM FURNISHED ON PG. 12.

**NOTE:** THE RED 12GA. WIRE WITH THE 30 AMP CIRCUIT BREAKER SHOULD BE CONNECTED TO A 12 VOLT POWER SOURCE OF AT LEAST 12GA. WIRE. CONNECT MOLDED PLUG WITH THE (RED, YELLOW, ORANGE) WIRES TO THE CORRESPONDING PLUG FROM THE BLOWER MOTOR. THE SINGLE WHITE WIRE FROM THE BLOWER MOTOR WITH THE RING TERMINAL MUST BE GROUNDED. THE BLUE CLUTCH WIRE RUNS FROM THE THERMOSTAT TO THE COMPRESSOR SAFETY SWITCH AND FROM THE SAFETY SWITCH TO THE COMPRESSOR. **BE CAREFUL TO ENSURE THAT THIS WIRE IS NOT PINCHED OR IN A POSITION TO RUB ON A SHARP EDGE AS IT PASSES THROUGH THE FIREWALL.**



## HEATER HOSE INSTALLATION

•AFTER THE EVAPORATOR IS IN PLACE, RUN 5/8" HEATER HOSE FROM THE HEATER TUBE NEAREST THE BLOWER ON THE EVAPORATOR THROUGH THE FIREWALL OR BEHIND THE KICK PANEL THROUGH FLOOR TO THE INTAKE MANIFOLD HEATER CONNECTION. INSTALL THE HEATER CONTROL VALVE IN THIS LINE (PRESSURE) SEE FIGURE BELOW. **(BE SURE TO FOLLOW FLOW ARROW ON HEATER CONTROL VALVE)**

•INSTALL 5/8" HEATER HOSE ON THE REMAINING HEATER TUBE. ROUTE HOSE THROUGH FIREWALL OR BEHIND KICK PANEL THRU FLOORBOARD AND OUT TO WATER PUMP CONNECTION. (SUCTION)

**FILL RADIATOR WITH AT LEAST A 50/50 MIXTURE OF APPROVED ANTIFREEZE AND WATER. IT IS THE OWNER'S RESPONSIBILITY TO KEEP THE FREEZE PROTECTION AT THE PROPER LEVEL FOR THE CLIMATE IN WHICH THE VEHICLE IS OPERATING. FAILURE TO FOLLOW ANTIFREEZE RECOMMENDATIONS WILL CAUSE HEATER CORE TO CORRODE PREMATURELY AND POSSIBLY BURST IN THE A/C MODE AND/OR FREEZING WEATHER, VOIDING YOUR WARRANTY. CHECK COMPLETE A/C ASSEMBLY FOR PROPER OPERATION. VINTAGE AIR RECOMMENDS THAT ALL A/C SYSTEMS BE SERVICED BY A CERTIFIED AUTOMOTIVE AIR CONDITIONING TECHNICIAN ONLY. SEE INSIDE COVER FOR SERVICE INFORMATION.**

•START ENGINE AND RUN, UNTIL NORMAL OPERATING TEMPERATURE IS REACHED. PLACE SWITCH IN HEAT POSITION (SEE FIGURE 4 PAGE 11), AND SELECT FAN SPEED DESIRED. THE SYSTEM WILL HEAT THE VEHICLE.

**IMPORTANT: (BE SURE THE ENGINE THERMOSTAT HAS OPENED, AND THE APPROVED ANTIFREEZE MIXTURE HAS BEEN CIRCULATED THROUGH THE HEATER CORE BEFORE TESTING THE A/C MODES).**

•WHEN VALVE IS CLOSED, INLET SIDE OF VALVE SHOULD BE HOT AND OUTLET SIDE SHOULD BE COOL. WHEN THE VALVE IS OPEN, BOTH INLET AND OUTLET SIDES SHOULD BE HOT.

•CONNECT WIRING ACCORDING TO PAGE 12.

•IF PREVIOUSLY REMOVED, REINSTALL DASH AND ENSURE THAT THE DUCT HOSE IS SECURELY ON THE DASH VENT HOSE ADAPTERS.

•**DON'T FORGET TO WRAP ANY EXPOSED #10 FITTINGS INSIDE THE CAR TO PREVENT CONDENSATION.**

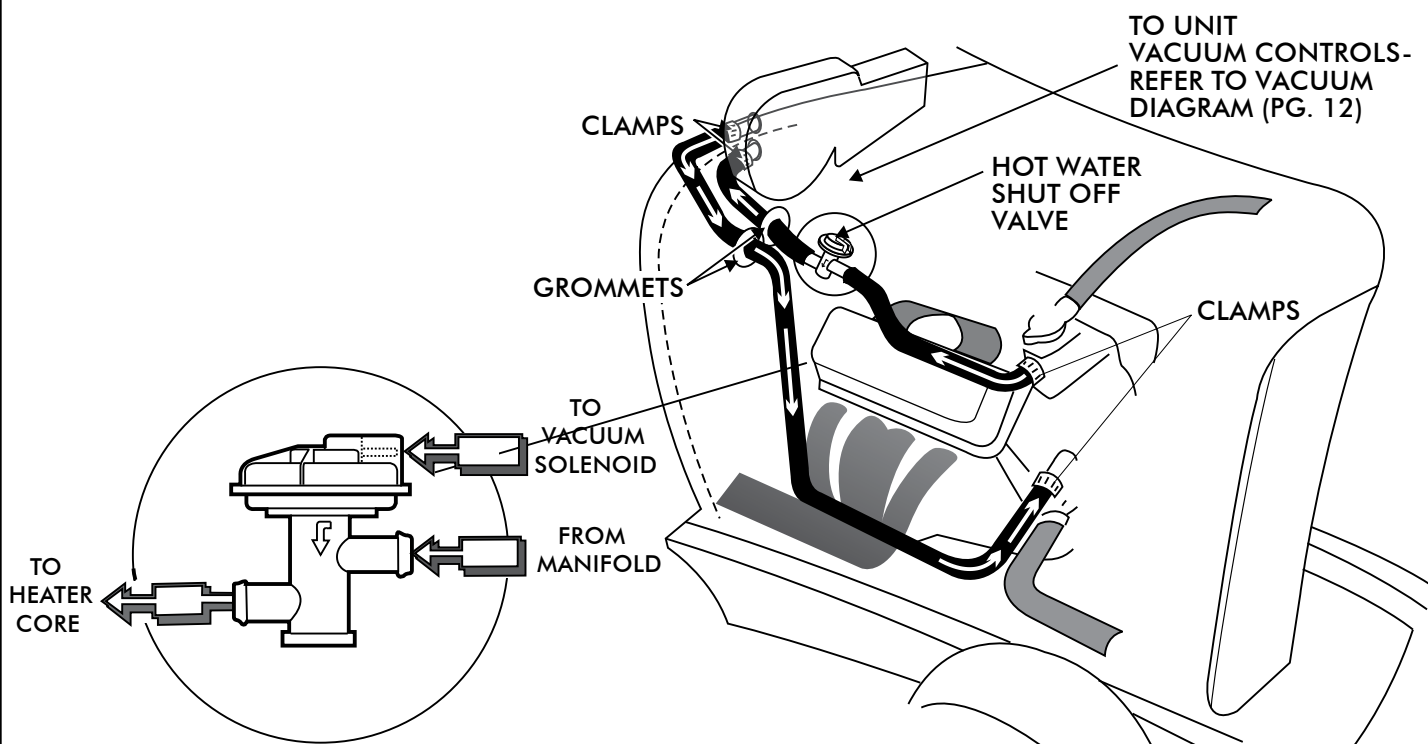



• IF PREVIOUSLY REMOVED, REINSTALL DASH AND ENSURE THAT THE DUCT HOSE IS SECURELY ON THE DASH VENT HOSE ADAPTERS.

• **DON'T FORGET TO WRAP ANY EXPOSED #10 FITTINGS INSIDE THE CAR TO PREVENT CONDENSATION.**

## OPERATION OF CONTROLS (SEE FIGURE 4, BELOW)

- THE SWITCH ON THE LEFT IS THE FAN SWITCH. IT CONTROLS THREE SPEED MOTOR.
- THE SWITCH ON THE RIGHT IS THE MODE SELECTION. FULL COUNTERCLOCKWISE POSITION IS ECONOMY POSITION. RECIRCULATED AIR SHOULD COME OUT THE DASH VENTS. IN THE FIRST POSITION (A/C POSITION), COLD AIR SHOULD COME OUT OF THE DASH VENTS. THE SECOND POSITION IS HEAT. HOT AIR WILL EXIT THE BOTTOM OF THE A/C PLENUM. THE HEATER VALVE LINE SHOULD HAVE VACUUM.
- FAN SPEED CAN BE OPERATED IN ANY MODE POSITION.

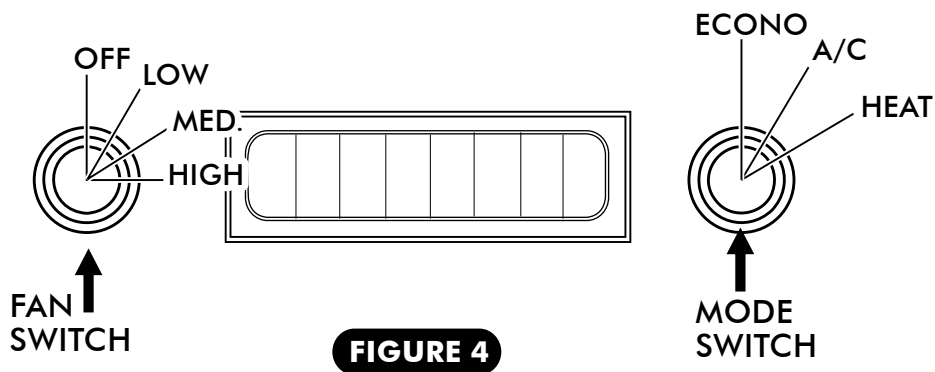

## FINAL STEPS

- REINSTALL ANY PREVIOUSLY REMOVED COMPONENTS (BATTERY, GLOVE BOX, RADIO, ETC.).
- FILL RADIATOR WITH AT LEAST A 50/50 MIXTURE OF APPROVED ANTIFREEZE AND WATER. IT IS THE OWNER'S RESPONSIBILITY TO KEEP THE FREEZE PROTECTION AT THE PROPER LEVEL FOR THE CLIMATE IN WHICH THE VEHICLE IS OPERATED. FAILURE TO FOLLOW ANTIFREEZE RECOMMENDATIONS WILL CAUSE HEATER CORE TO CORRODE PREMATURELY AND POSSIBLY BURST IN A/C MODE AND/OR FREEZING WEATHER, VOIDING YOUR WARRANTY.
- CHECK COMPLETE A/C ASSEMBLY FOR PROPER OPERATION.
- VINTAGE AIR RECOMMENDS THAT ALL A/C SYSTEMS BE SERVICED BY A CERTIFIED AUTOMOTIVE AIR CONDITIONING TECHNICIAN ONLY. SEE INSIDE COVER FOR SERVICE INFORMATION.



# WIRING/VACUUM DIAGRAM HEAT & COOL

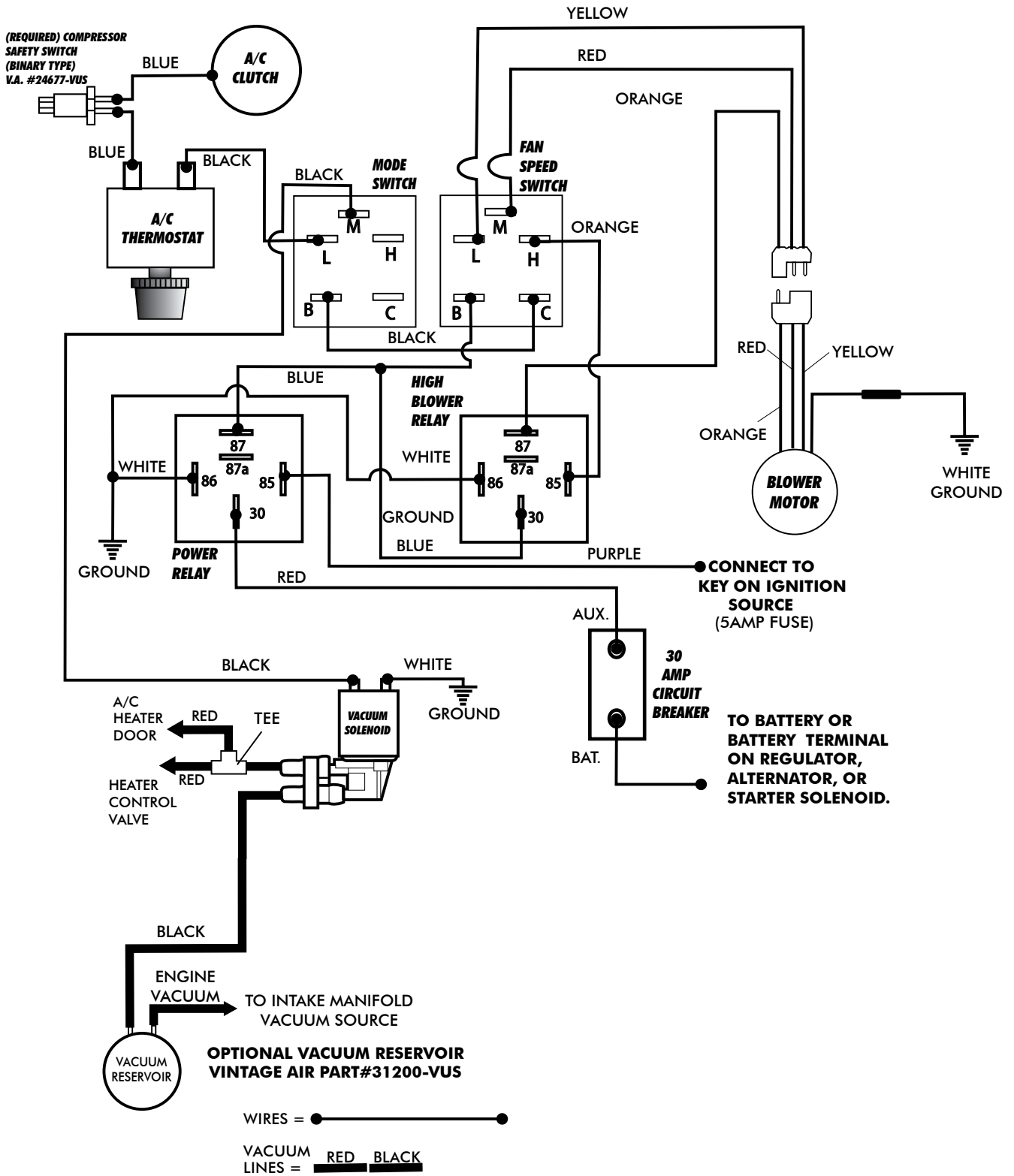

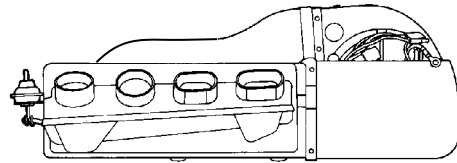
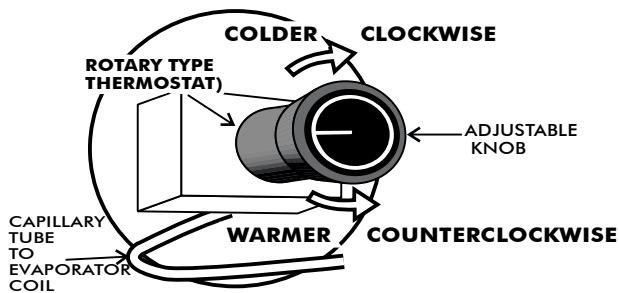

THIS STICKER LOCATED ON TOP SIDE OF EVAPORATOR CASE

EVAPORATOR

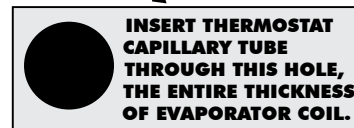
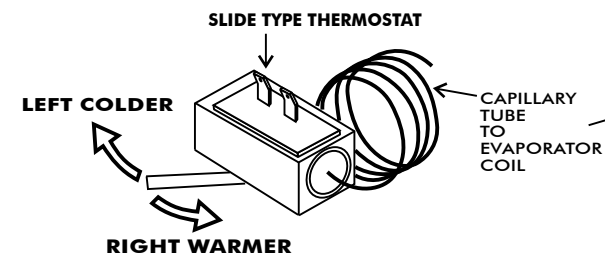

**NOTE: YOUR SYSTEM MAY HAVE A ROTARY OR SLIDE TYPE THERMOSTAT. IF YOU ARE UPGRADING TO A NEW CONTROL PANEL, USE THE THERMOSTAT INCLUDED WITH THE NEW PANEL. REMOVE YOUR ORIGINAL THERMOSTAT AND DISCARD.**

## AIR CONDITIONING ADJUSTMENTS:

- THE AIR CONDITIONER THERMOSTAT CONTROLS COIL TEMPERATURE. ROTARY TYPE THERMOSTATS ARE SHIPPED ADJUSTED FULLY COLD (CLOCKWISE), IN THE MAJORITY OF CASES THE A/C WILL OPERATE CORRECTLY AS SHIPPED.
- TURNING THE KNOB ON THE **ROTARY TYPE THERMOSTAT** TO THE RIGHT (CLOCKWISE) MAKES THE SYSTEM OPERATE COLDER. MOVING THE LEVER TOWARD COLDER ON THE **SLIDE TYPE THERMOSTAT** MAKES THE SYSTEM OPERATE COLDER. IF THE THERMOSTAT IS SET TOO COLD, THE EVAPORATOR COIL WILL "ICE UP," MEANING THE EVAPORATOR COIL IS RESTRICTED WITH ICE AND COLD AIR FLOW WILL BE REDUCED.
- TURNING THE KNOB TO THE LEFT (COUNTERCLOCKWISE) ON A **ROTARY TYPE THERMOSTAT** MAKES THE SYSTEM OPERATE WARMER. MOVING THE LEVER TOWARD THE RED LINES ON A **SLIDE TYPE THERMOSTAT** MAKES THE SYSTEM OPERATE WARMER. THE COMPRESSOR CLUTCH WILL CYCLE OFF FREQUENTLY. THE EVAPORATOR COIL WILL NOT GET AS COLD, AND THE AIR TEMPERATURE WILL NOT BE AS COLD.

## ADJUSTING A/C THERMOSTAT

- 1.) **SYMPTOM:** THE A/C WORKS WELL AT FIRST, THEN QUILTS COOLING. THE AIR FLOW FROM THE VENTS IS LOW, AND THE COMPRESSOR CLUTCH CYCLES INFREQUENTLY.  
**SOLUTION:** THE THERMOSTAT IS SET TOO COLD AND THE EVAPORATOR IS "ICING UP" AND RESTRICTING AIR FLOW. **ALLOW THE ICE TO MELT** AND SET THE **ROTARY TYPE THERMOSTAT** WARMER (COUNTER CLOCKWISE) 1/8 OF A TURN EACH ADJUSTMENT UNTIL THE SYMPTOMS DIMINISH. ADJUST THE **SLIDE TYPE THERMOSTAT** IN 1/8" INCREMENTS TOWARD THE SMALLER BLUE GRADIENTS, UNTIL THE SYMPTOMS DIMINISH.
- 2.) **SYMPTOM:** A/C NEVER GETS COLD AND THE COMPRESSOR CLUTCH CYCLES FREQUENTLY.  
**SOLUTION:** THE THERMOSTAT IS SET TOO WARM. SET THE **ROTARY TYPE THERMOSTAT** COLDER (CLOCKWISE) 1/8 OF A TURN EACH ADJUSTMENT, UNTIL THE DESIRED AIR TEMPERATURE IS REACHED. ADJUST **SLIDE TYPE THERMOSTAT** IN 1/8" INCREMENTS TOWARD COLDER UNTIL THE DESIRED AIR TEMP IS REACHED.  
**AVOID SETTING THE THERMOSTAT TOO COLD.**
- 3.) **SYMPTOM:** THE A/C NEVER GETS COLD, SOMETIMES EVEN BLOWS HOT, AND THE A/C COMPRESSOR CLUTCH INFREQUENTLY CYCLES OFF.  
**SOLUTION:** THE HEATER MAY BE ON AT ALL TIMES. **CAREFULLY** FEEL THE HEATER HOSE BETWEEN THE **EVAPORATOR** AND THE **HEATER CONTROL VALVE**. THIS HOSE SHOULD NOT BE HOT IN THE **A/C MODE**. IF THE HOSES ARE HOT ....
  - A)- THE HEATER CONTROL VALVE MAY BE INSTALLED BACKWARDS. CHECK THE FLOW DIRECTION ARROW ON THE VALVE AGAINST THE ILLUSTRATION IN YOUR INSTALLATION INSTRUCTIONS.
  - B)- IF CABLE OPERATED: THE VALVE MAY BE MISADJUSTED.
  - C)- IF VACUUM OPERATED: IT MAY BE GETTING VACUUM AT ALL TIMES (CHECK ELECTRIC SOLENOID).
  - D)- THE HEATER CONTROL VALVE MAY BE INSTALLED IN THE WRONG HOSE. IT MUST BE INSTALLED IN THE HOSE COMING FROM THE INTAKE MANIFOLD ENGINE COOLANT **PRESSURE PORT**.



EVAPORATOR KIT

61000-QUX-A \_\_\_\_\_

61000-VUX-A \_\_\_\_\_

EVAPORATOR KIT PACKING LIST

No.	QTY.	PART No.	DESCRIPTION
1.	1	55256-VUE-A	EVAPORATOR w/ BLOWER SUB CASE _____
2.	1	63250-VUE	INSTALLATION KIT _____
3.	13	06250-VUE	2 1/2" DUCT HOSE _____
4.	1	63522-KUB	EVAPORATOR MNTG BRKT. KIT _____

CHECKED BY: \_\_\_\_\_

PACKED BY: \_\_\_\_\_

DATE: \_\_\_\_\_

①

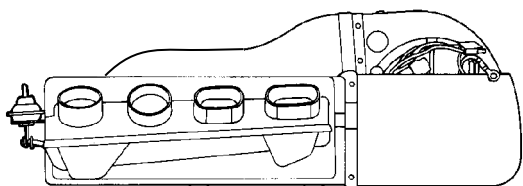

②

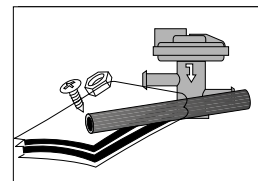

③

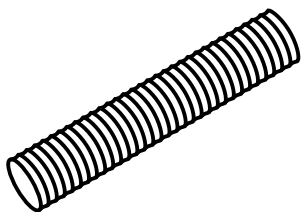

④

