



1964-67 Chevrolet Chevelle

Condenser Kit *with* Drier
(021252)



18865 Goll St. San Antonio, TX 78266
Phone: 800-862-6658
Sales: sales@vintageair.com
Tech Support: tech@vintageair.com
www.vintageair.com



www.vintageair.com

Table of Contents

Cover.....	1
Table of Contents.....	2
Packing List/Parts Disclaimer.....	3
Important Notice.....	4
Core Support Measurements.....	5
Mounting Bracket Installation.....	6
Radiator and Hood Latch Assembly Removal, Condenser Installation.....	7-8
Drier and Binary Switch Installation, Lubricating O-rings.....	9
A/C Hose Installation, Final Steps.....	10
Packing List.....	11



www.vintageair.com

Packing List: Condenser Kit (021252)

No.	Qty.	Part No.	Description
1.	1	03767-VUC	Condenser, 14" x 24", Parallel Flow
2.	1	656030	Drier Clamp
3.	1	07321-VUC	Drier
4.	1	18249-VUB	Screw, 10-24 x 3/8", Pan Head
5.	1	18260-VUB	Nut with Star Washer, 10-24
6.	1	18266-VUB	Screw, #14 x 3/4", Washer Head
7.	1	18611-VUB	Washer, 5/16", Flat
8.	2	33857-VUF	O-ring, #6
9.	1	31603-VUD	Adel Clamp, 1/2" I.D.
10.	8	18979-VUB	J-nut, #8
11.	8	18235-VUB	Screw, #8 x 1/2", Pan Head
12.	1	643207	Bracket, Condenser, Bottom
13.	1	643208	Bracket, Condenser, Top
14.	1	092134	Hose, #6 A/C, Condenser/Drier, Reduced Barrier
15.	1	11079-VUS	Binary Switch, Male
16.	1	23135-VUW	Compressor Lead
17.	1	64359-VCB	Bracket, Adel Clamp
18.	1	18290-VUB	Bolt, 1/4-20 x 1", Hex
19.	2	18125-VUB	Washer, 1/4" USS, Flat
20.	1	18152-VUB	Nut with Star Washer, 1/4-20, Hex
21.	1	41117-VUP	Refrigerant Oil

**** Before beginning installation, open all packages and check contents of shipment. Please report any shortages directly to Vintage Air within 15 days. After 15 days, Vintage Air will not be responsible for missing or damaged items.**

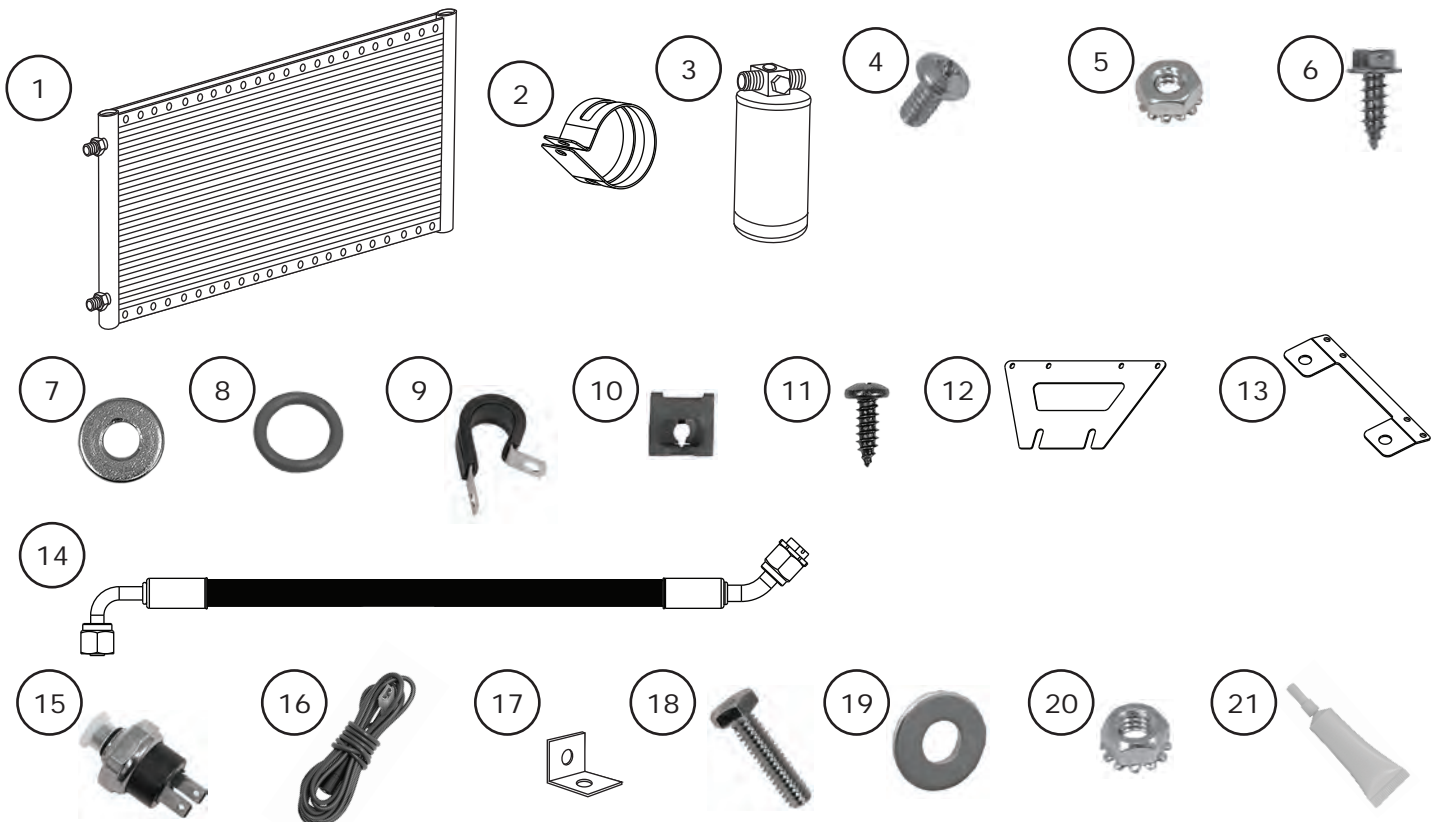

NOTE: Images may not depict actual parts and quantities. Refer to packing list for actual parts and quantities.



www.vintageair.com

Important Notice—Please Read

For Maximum System Performance, Vintage Air Recommends the Following:

NOTE: Vintage Air systems are designed to operate with R134a refrigerant only. Use of any other refrigerant could damage your A/C system and/or vehicle, and possibly cause a fire, in addition to potentially voiding the warranties of the A/C system and its components.

Refrigerant Capacities:

Vintage Air System: 1.8 lbs. (28.8 oz.) or 816 grams of **R134a**, charged by weight with a quality charging station or scale. **NOTE: Use of the proper type and amount of refrigerant is critical to system operation and performance.**

Other Systems: Consult manufacturer's guidelines.

Lubricant Capacities:

New Vintage Air-Supplied Sanden Compressor: No additional oil needed (Compressor is shipped with proper oil charge).

All Other Compressors: Consult manufacturer (Some compressors are shipped dry and will need oil added).

Safety Switches

Your Vintage Air system is equipped with a binary pressure safety switch. A binary switch disengages the compressor clutch in cases of extreme low pressure conditions (refrigerant loss) or excessively high head pressure (406 PSI) to prevent compressor damage or hose rupture. A trinary switch combines Hi/Lo pressure protection with an electric fan operation signal at 254 PSI, and should be substituted for use with electric fans. Compressor safety switches are extremely important since an A/C system relies on refrigerant to circulate lubricant.

Service Info:

Protect Your Investment: Prior to assembly, it is critical that the compressor, evaporator, A/C hoses and fittings, hardlines, condenser and receiver/drier remain capped. Removing caps prior to assembly will allow moisture, insects and debris into the components, possibly leading to reduced performance and/or premature failure of your A/C system. This is especially important with the receiver/drier.

Additionally, when caps are removed for assembly, **BE CAREFUL!** Some components are shipped under pressure with dry nitrogen.

Evacuate the System for 35-45 Minutes: Ensure that system components (Drier, compressor, evaporator and condenser) are at a temperature of at least 85°F. On a cool day, the components can be heated with a heat gun **or** by running the engine with the heater on before evacuating. Leak check and charge to specifications.

Bolts Passing Through Cowl and/or Firewall:

To ensure a watertight seal between the passenger compartment and the vehicle exterior, for all bolts passing through the cowl and/or firewall, Vintage Air recommends coating the threads with silicone prior to installation.

Heater Hose (not included with this kit):

Heater hose may be purchased from Vintage Air (Part#31800-VUD) or your local parts retailer. Routing and required length will vary based on installer preference.



www.vintageair.com

Core Support Measurements

This kit was developed based on the measurements below, which were taken from a 1967 Chevrolet Chevelle with factory air core support.

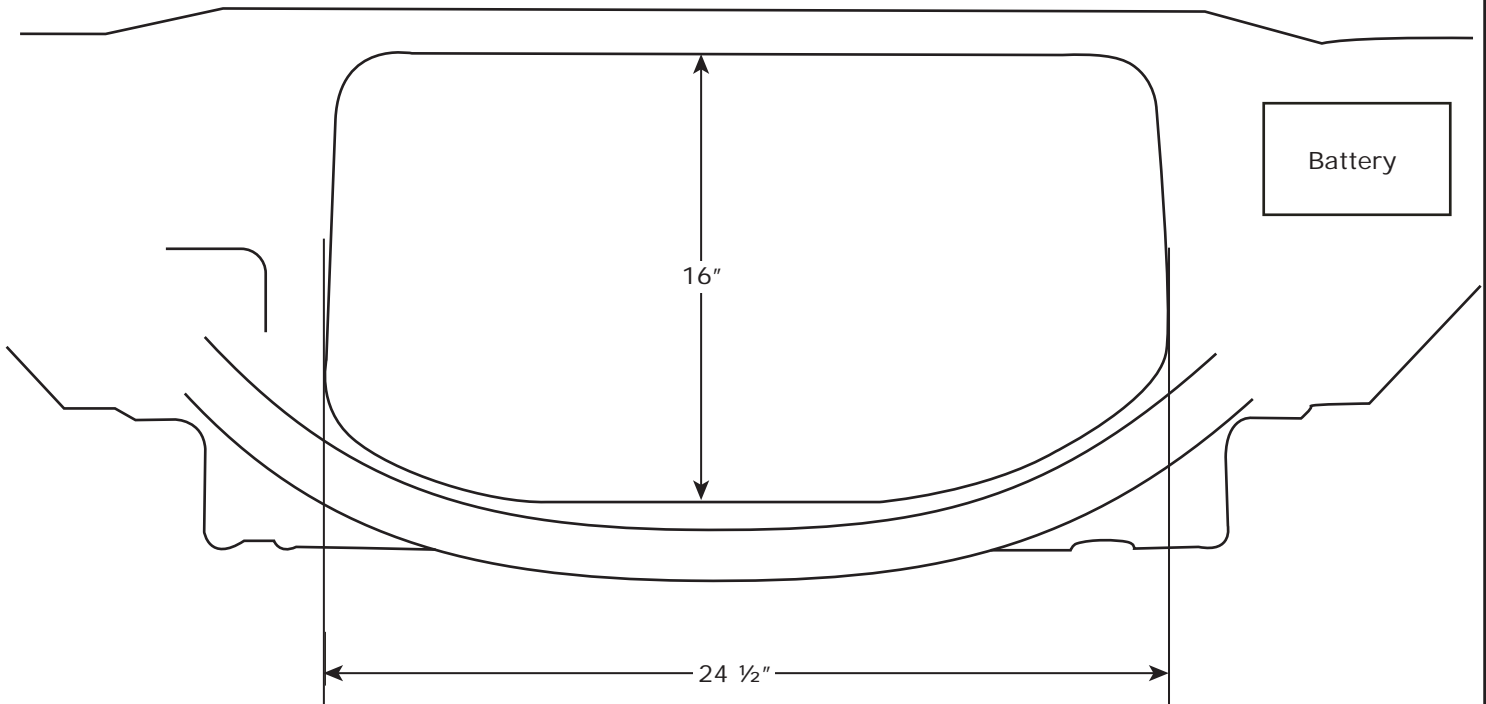



www.vintageair.com

Mounting Bracket Installation

1. Secure the top condenser bracket onto the condenser using (4) #8 J-nuts and (4) #8 x 1/2" pan head screws (See Photos 1, 2 and 3, below). **NOTE: The bracket mounts onto the outside of the flange through the 7th, 8th, 12th and 13th holes from the left side of the condenser (See Photo 2, below).**
2. Flip the condenser over, and install (4) #8 J-nuts onto the lower condenser mount in the 10th, 12th, 16th, and 18th holes (See Photo 4, below).
3. Secure the bottom condenser bracket onto the condenser using (4) #8 x 1/2" pan head screws (See Photo 5, below).

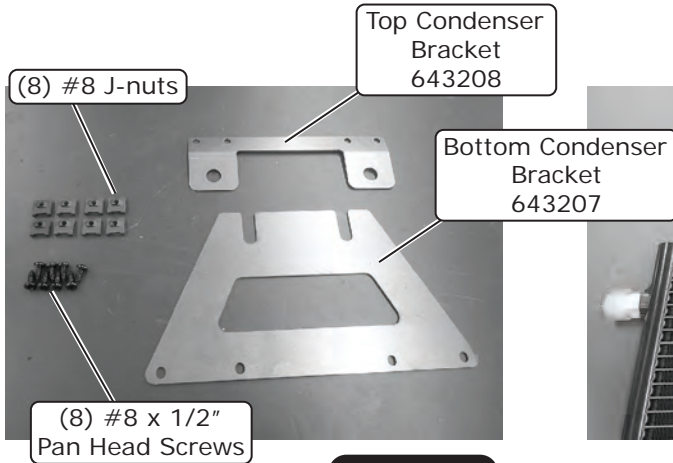

Photo 1

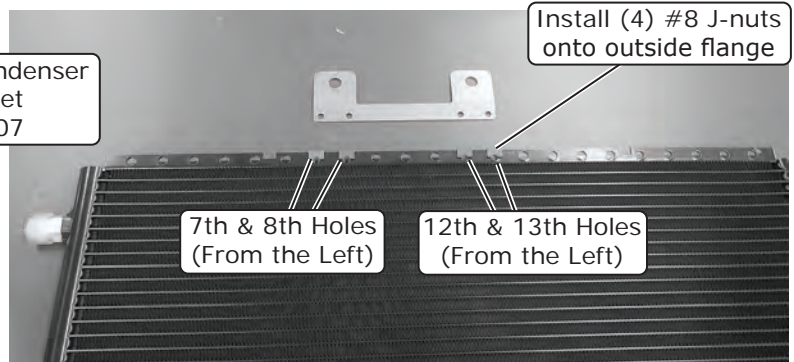

Photo 2

Secure top condenser bracket onto condenser using (4) #8 x 1/2" pan head screws

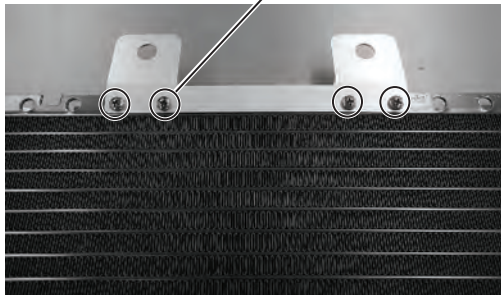

Photo 3

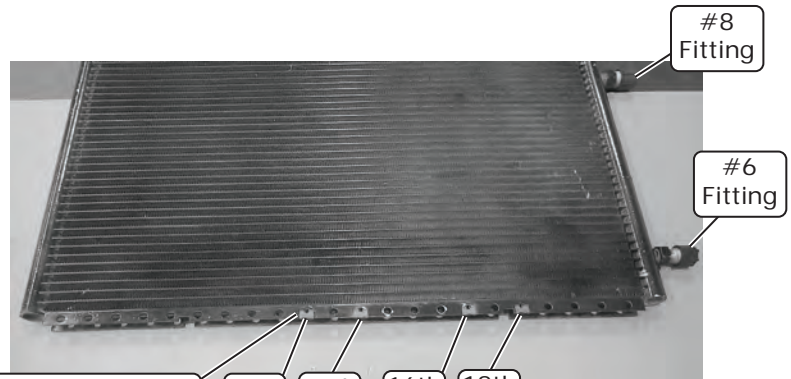

Photo 4

Install (4) #8 J-nuts onto condenser flange

Secure bottom condenser bracket onto condenser using (4) #8 x 1/2" pan head screws

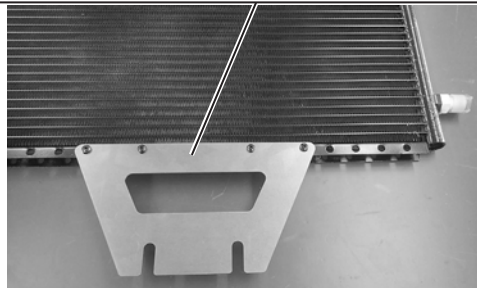

Photo 5



www.vintageair.com

Radiator and Hood Latch Assembly Removal

1. Drain the radiator.
2. Remove the upper and lower radiator hoses.
3. Remove the radiator cooling fan and fan shroud.
4. Remove the radiator.
5. Remove the OEM hood latch assembly (See Figure 1, below).

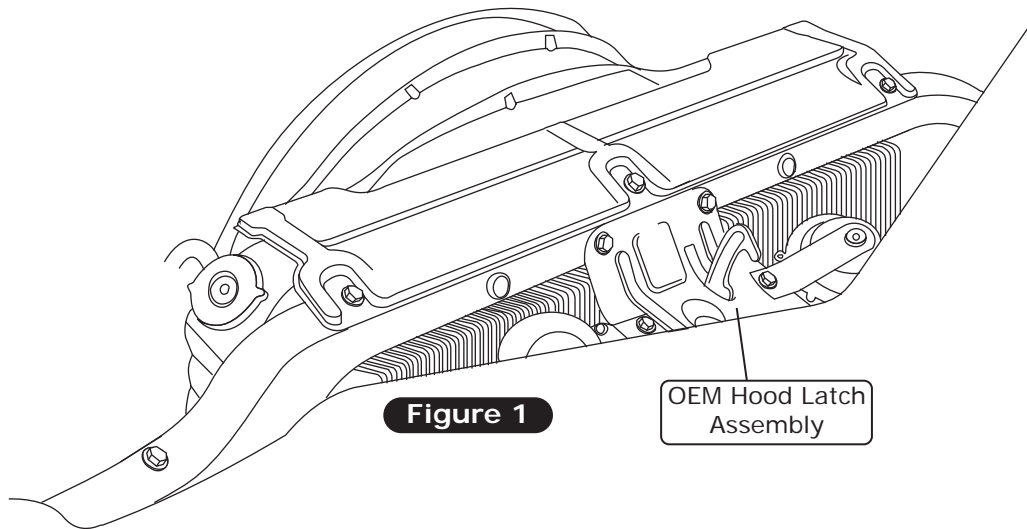

Figure 1

Condenser Installation

1. For ease of installation, remove the plastic caps. **NOTE: Once the condenser is in place reinstall the caps.**
2. Lower the condenser assembly into the vehicle from the engine side of the core support (See Figure 1, below). **NOTE: The top condenser bracket mounts on the front side of the core support (See Figure 2, Page 8).**

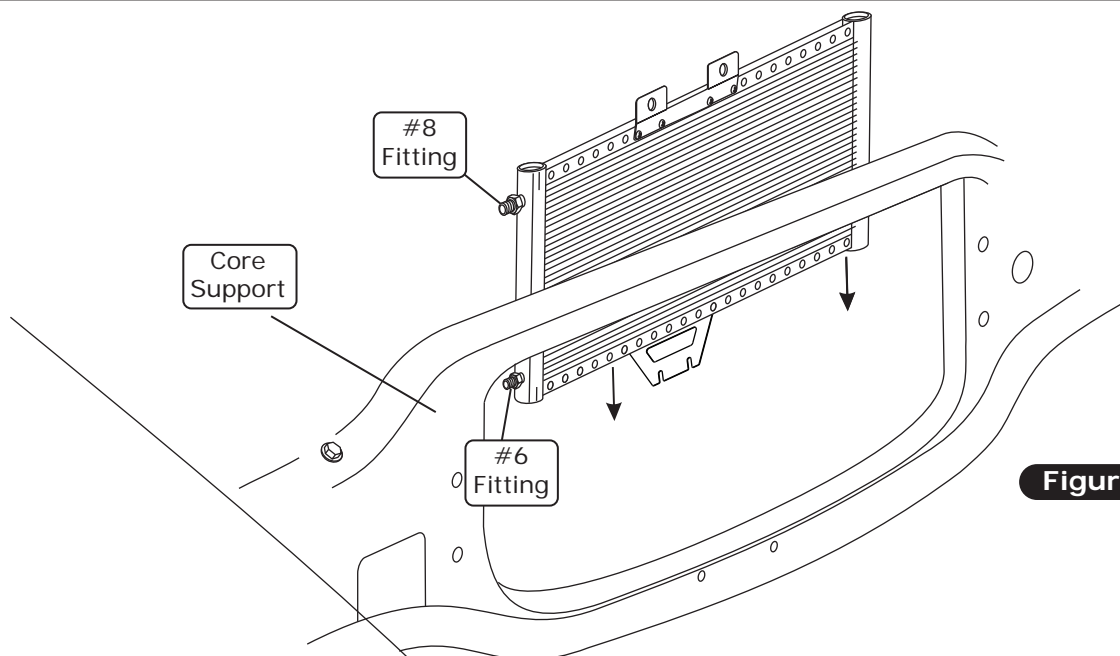

Figure 1



www.vintageair.com

Condenser Installation (Cont.)

3. Secure the bottom passenger side of the condenser to the core support using the OEM bolt.
4. Using the driver-side mounting hole as a guide, drill a 3/16" hole in the core support.
5. Secure the condenser to the core support using a #14 x 3/4" washer head screw and a 5/16" flat washer (See Figure 2, below).
6. Reinstall the hood latch assembly using the OEM bolts. Install the OEM bolts through the hood latch assembly, top mounting bracket and core support (See Figure 3, below).

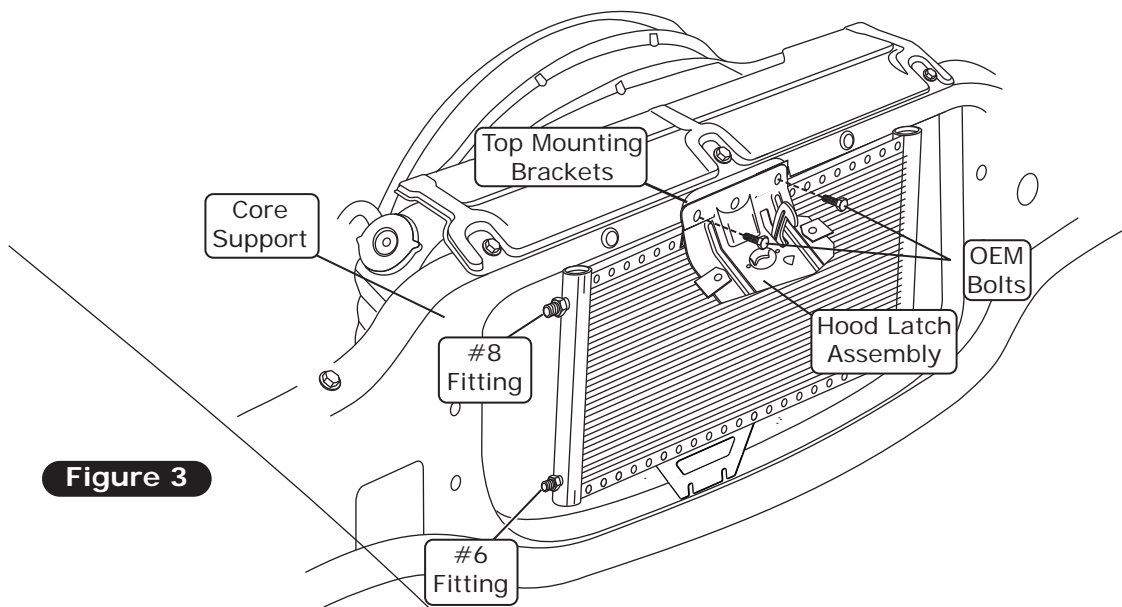
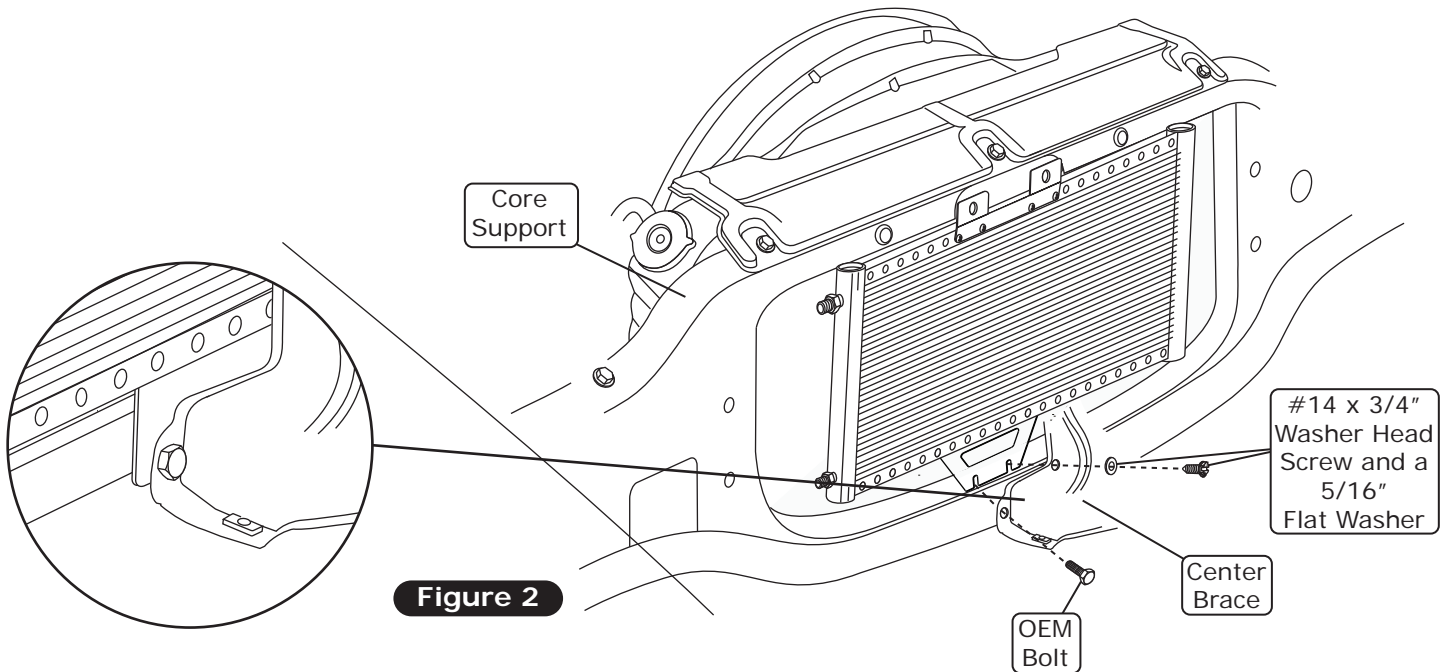



www.vintageair.com

Drier and Binary Switch Installation

NOTE: Do not remove the caps from the drier. The drier contains a desiccant that will quickly absorb moisture from the air, causing it to lose effectiveness. For this reason, Vintage Air recommends that the drier remains capped until the installer is ready to evacuate the system.

Perform the following:

1. Mount the drier onto the passenger-side inner fenderwell.
2. Vehicles with factory air will use the lower 5/16" OEM existing factory hole (See Figure 1, below). Vehicles without factory air will use the lower OEM dimple as a guide and drill a 5/16" hole (See Figure 1, below).
3. Install the drier/drier clamp assembly onto the inner fenderwell using a 1/4-20 x 1" hex bolt, (2) 1/4" USS flat washers (use (1) on each side of the inner fenderwell) and a 1/4-20 nut with star washer. **NOTE: Refrigerant flow through drier is IN from condenser, OUT to evaporator.**
4. Install the binary switch onto the drier as shown in Figure 1, below.

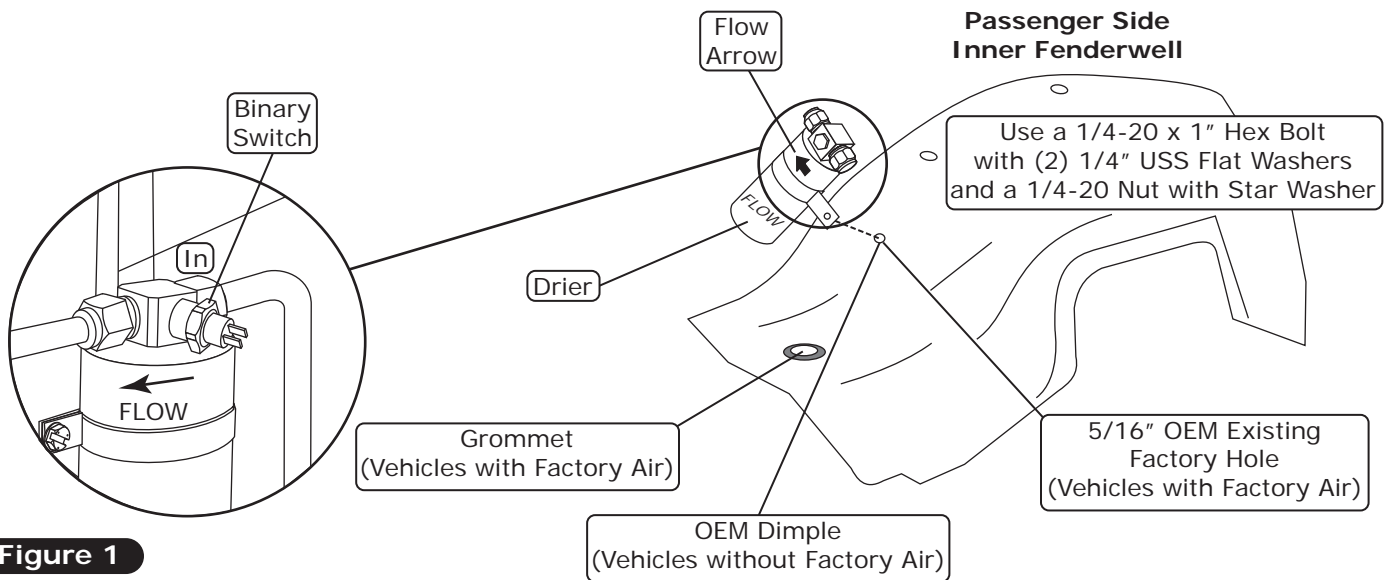
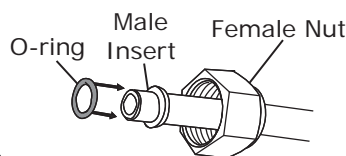
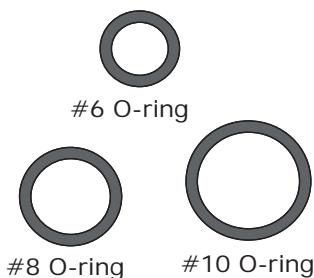

Figure 1

Lubricating O-rings



For a proper seal of fittings: Install supplied O-rings as shown and lubricate with refrigerant oil.

Refrigerant Oil for O-rings

O-ring installs over male insert to swaged lip

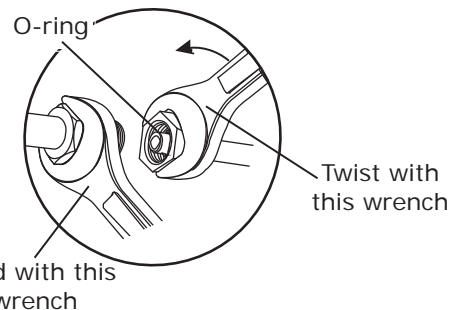

NOTE: Standard torque specifications:

- #6: 11 to 13 ft.-lb.
- #8: 15 to 20 ft.-lb.
- #10: 21 to 27 ft.-lb.



www.vintageair.com

A/C Hose Installation

1. Lubricate (2) #6 O-rings, and install one onto each end of the #6 drier/condenser A/C hose.
2. Install the #6 A/C hose 90° fitting onto the #6 condenser fitting (See Photo 1, below), then onto the drier (See Photo 2, below).
3. Install the Adel clamp bracket onto the frame using the OEM bolt (See Photo 3, below).
4. Using a 10-24 x 3/8" pan head screw and 10-24 nut with star washer, secure the #6 A/C hose to the Adel clamp bracket using the supplied 1/2" I.D. Adel clamp (See Photo 4, below). **NOTE: The #8 condenser/compressor A/C hose will be included in the A/C hose kit.**

Install #6 A/C hose
90° fitting onto #6
condenser fitting

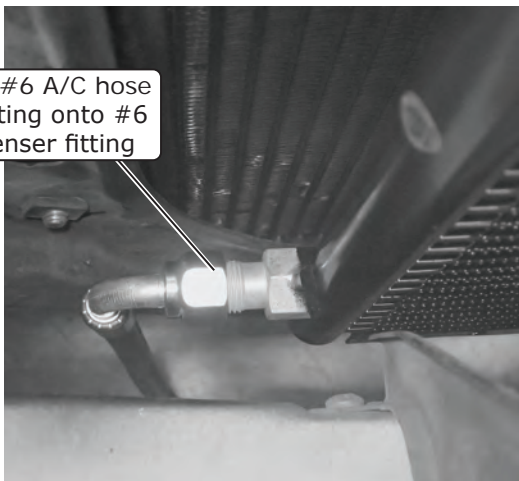

Photo 1

Install #6 A/C hose
45° fitting onto drier

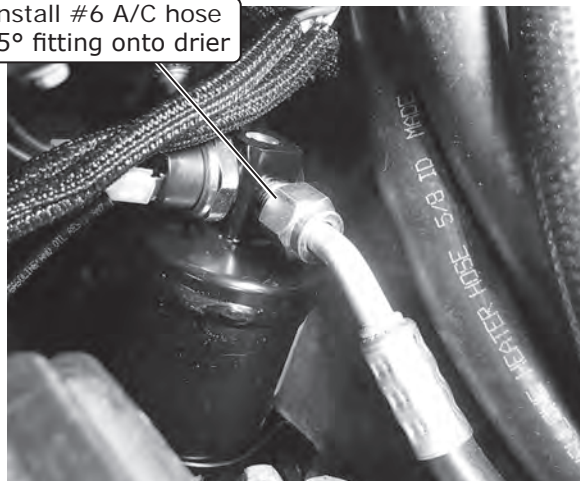

Photo 2

Install Adel clamp
bracket onto frame
using OEM bolt

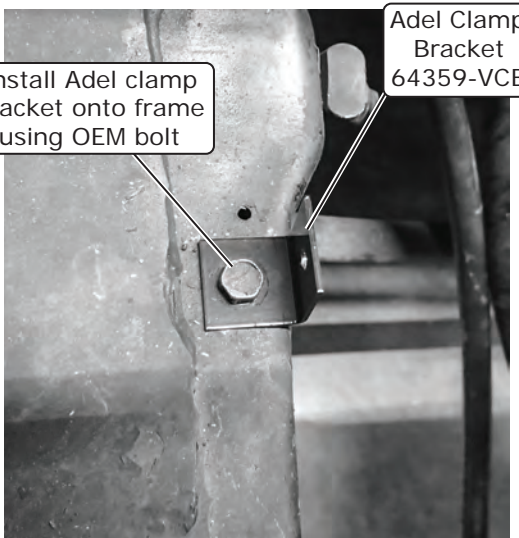

Photo 3

10-24 Nut with
Star Washer

10-24 x 3/8"
Pan Head Screw

1/2" I.D.
Adel Clamp

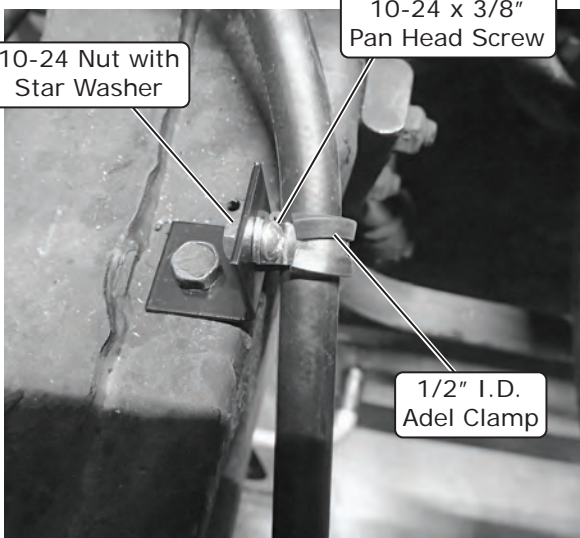

Photo 4

Final Steps

1. Reinstall the radiator, fan and fan shroud. This concludes the condenser kit portion of your installation.



www.vintageair.com

Packing List: Condenser Kit (021252)

No.	Qty.	Part No.	Description
1.	1	03767-VUC	Condenser, 14" x 24", Parallel Flow
2.	1	656030	Drier Clamp
3.	1	07321-VUC	Drier
4.	1	18249-VUB	Screw, 10-24 x 3/8", Pan Head
5.	1	18260-VUB	Nut with Star Washer, 10-24
6.	1	18266-VUB	Screw, #14 x 3/4", Washer Head
7.	1	18611-VUB	Washer, 5/16", Flat
8.	2	33857-VUF	O-ring, #6
9.	1	31603-VUD	Adel Clamp, 1/2" I.D.
10.	8	18979-VUB	J-nut, #8
11.	8	18235-VUB	Screw, #8 x 1/2", Pan Head
12.	1	643207	Bracket, Condenser, Bottom
13.	1	643208	Bracket, Condenser, Top
14.	1	092134	Hose, #6 A/C, Condenser/Drier, Reduced Barrier
15.	1	11079-VUS	Binary Switch, Male
16.	1	23135-VUW	Compressor Lead
17.	1	64359-VCB	Bracket, Adel Clamp
18.	1	18290-VUB	Bolt, 1/4-20 x 1", Hex
19.	2	18125-VUB	Washer, 1/4" USS, Flat
20.	1	18152-VUB	Nut with Star Washer, 1/4-20, Hex
21.	1	41117-VUP	Refrigerant Oil

Checked By: _____
Packed By: _____
Date: _____

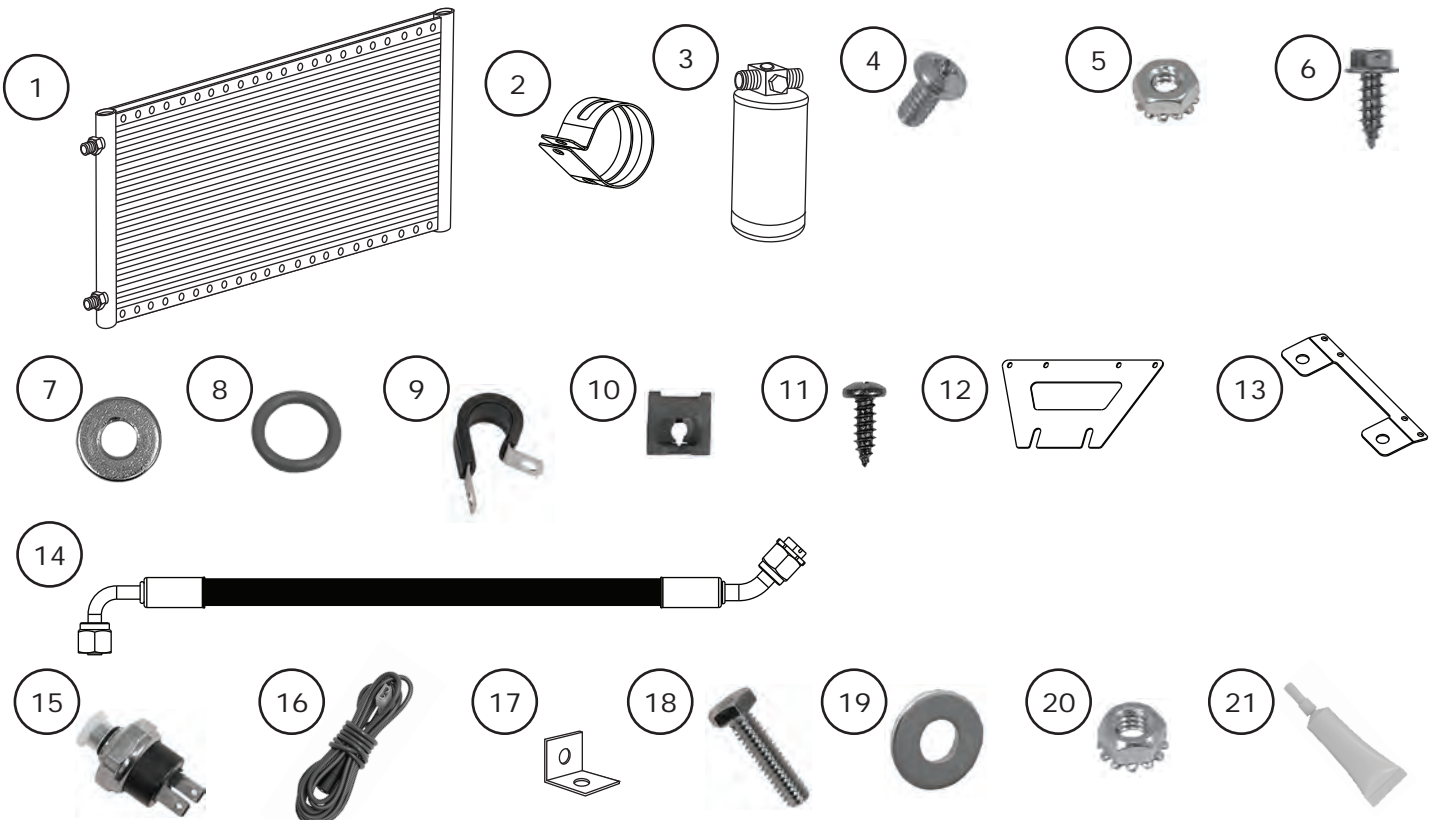

**NOTE: Images may not depict actual parts and quantities.
Refer to packing list for actual parts and quantities.**