

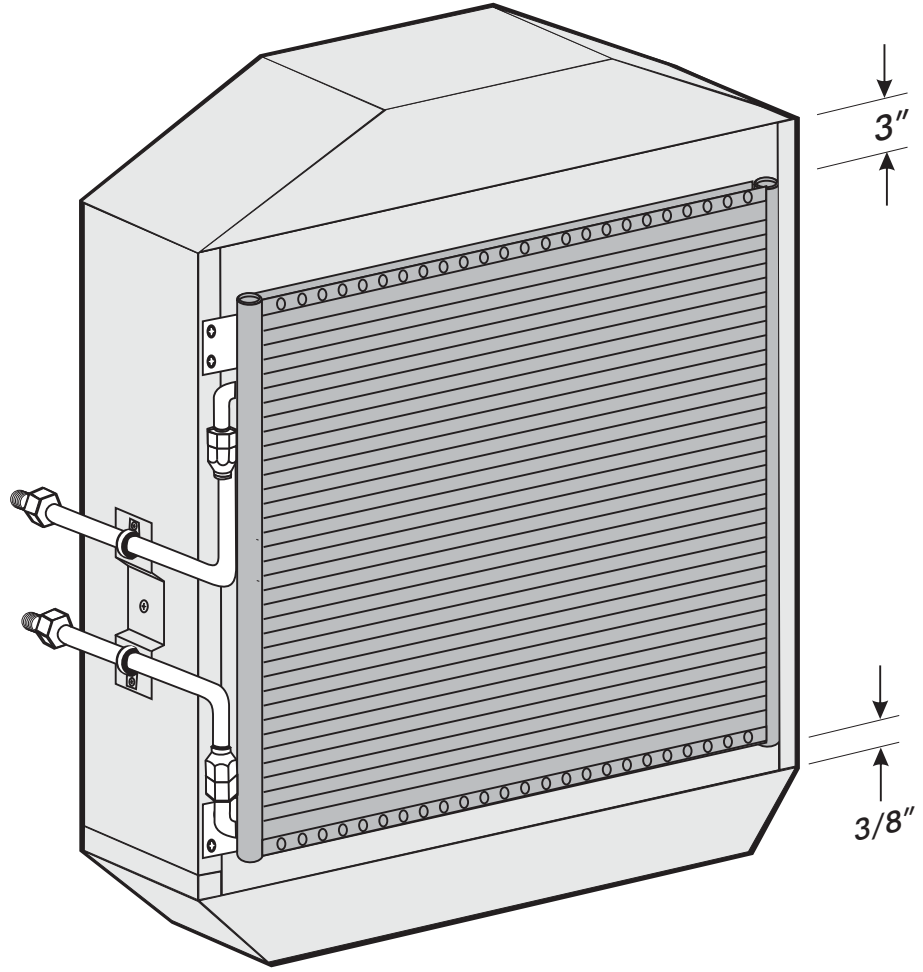

1939-40 FORD

CONDENSER KIT w/o DRIER
03040-VFC



CONDENSER KIT w/o DRIER PACKING LIST

No.	QTY.	PART No.	DESCRIPTION	
1.	1	03768-VUC	17 X 19 PARALLEL FLOW COND.	_____
2.	1	35178-VFG	#6 ALUMINUM HARDLINE (COND-CORE)	_____
3.	1	35177-VFG	#8 ALUMINUM HARDLINE (COND-CORE)	_____
4.	8	18233-VUB	#6 x 3/8" SHEET METAL SCREWS	_____
5.	1	33857-VUF	#6 O-RING	_____
6.	1	33858-VUF	#8 O-RING	_____
7.	1	16039-VFB	39-40 FORD COND. HARDLINE KIT	_____

CHECKED BY: _____
 PACKED BY: _____
 DATE: _____