

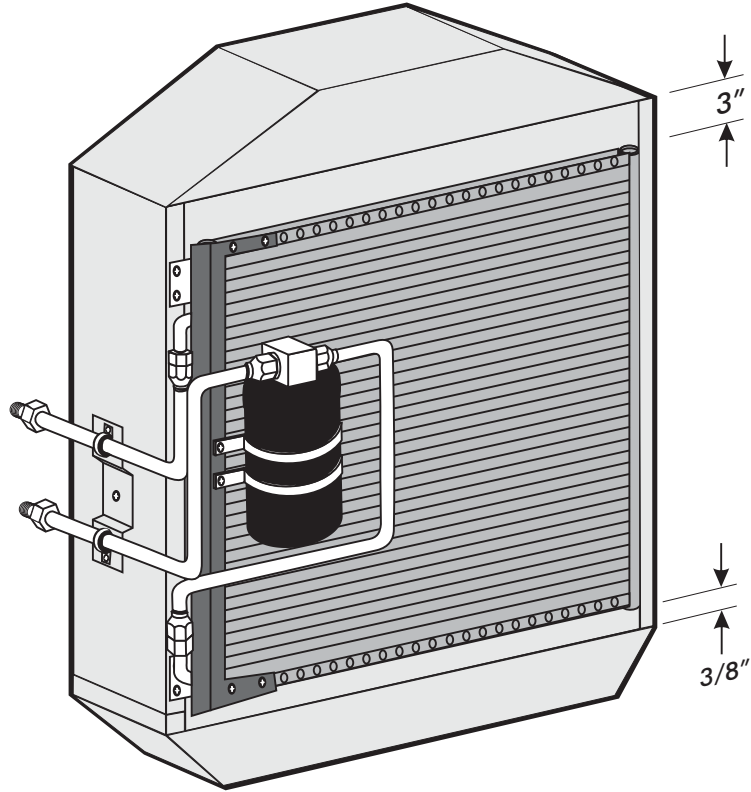

1939-40 FORD

CONDENSER KIT w/ DRIER
03140-VFC



CONDENSER KIT w/ DRIER PACKING LIST

No.	QTY.	PART No.	DESCRIPTION	
1.	1	03768-VUC	17 X 19 PARALLEL FLOW COND.	_____
2.	1	64776-VUB	17" DRIER BRACKET	_____
3.	2	07113-VUB	DRIER CLAMP	_____
4.	1	07321-VUC	DRIER	_____
5.	2	18247-VUB	#10 X 1/2" SHEET METAL SCREWS	_____
6.	4	18249-VUB	10 X 24 SCREWS	_____
7.	4	18260-VUB	10 X 24 NUTS W/STAR WASHER	_____
8.	8	18233-VUB	#6 X 3/8" SHEET METAL SCREWS	_____
9.	1	35175-VFG	#6 ALUMINUM HARDLINE (COND-DRIER)	_____
10.	1	35176-VFG	#6 ALUMINUM HARDLINE (DRIER-CORE)	_____
11.	1	35177-VFG	#8 ALUMINUM HARDLINE (COND-CORE)	_____
12.	3	33857-VUF	#6 O-RING	_____
13.	1	33858-VUF	#8 O-RING	_____
14.	1	16039-VFB	39-40 FORD COND. HARDLINE KIT	_____

CHECKED BY: _____
 PACKED BY: _____
 DATE: _____