



an ISO 9001:2008 Registered Company

MINI SLIMLINE

COOL

10301-VUY-A

10401-VUY-A

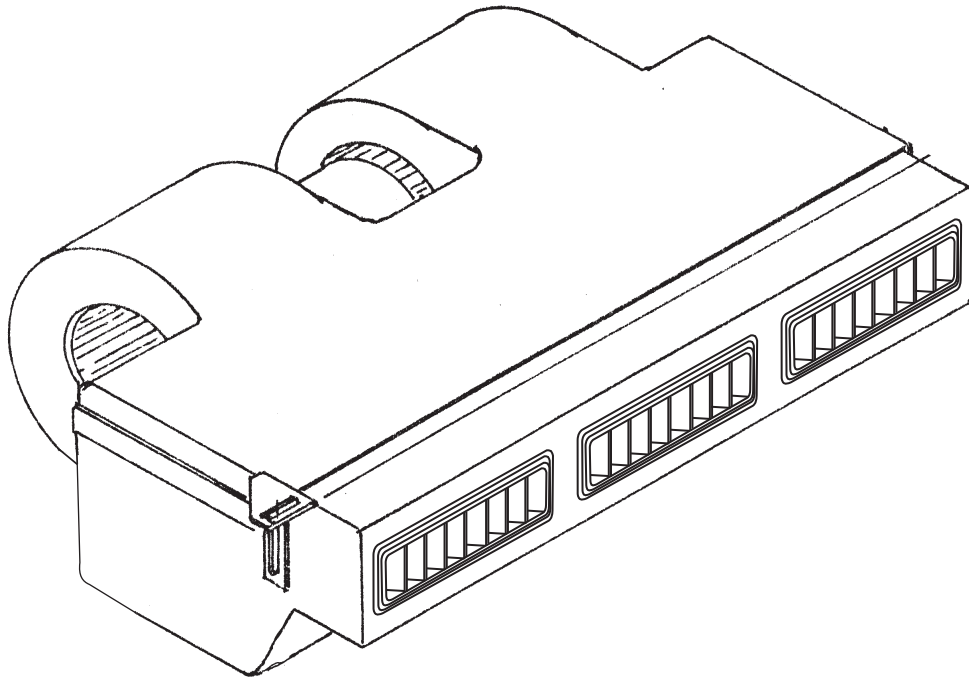

18865 GOLL ST. - SAN ANTONIO, TX. - 78266 ph.210-654-7171 - fax 210-654-3113



Table of Contents

PAGES

1. COVER
2. TABLE OF CONTENTS
3. PACKING LIST
4. INFORMATION PAGE
5. INSTALLATION
6. INSTALLATION CONTINUED
7. HOSE ROUTING
8. O-RING/FITTING INSTRUCTIONS
9. WIRING DIAGRAM
10. THERMOSTAT ADJUSTMENT
11. EVAPORATOR KIT PACKING LIST



EVAPORATOR KIT
10301-VUY-A
10401-VUY-A

EVAPORATOR KIT PACKING LIST

No.	QTY.	PART No.	DESCRIPTION
1.	1	55325-VUE-A	EVAPORATOR SUB CASE COOL ONLY w/ STD LOUVERS
		55425-VUE-A	EVAPORATOR SUB CASE COOL ONLY w/ BLK LOUVERS
2.	1	64143-VUE	EVAPORATOR MOUNTING BRKT. KIT
3.	1	49140-VUY	CONTROL POD W/ WIRING
4.	1	63301-VUE	INSTALLATION KIT (COOL ONLY)

**** BEFORE BEGINNING INSTALLATION, OPEN ALL PACKAGES AND CHECK CONTENTS OF SHIPMENT. PLEASE REPORT ANY SHORTAGES DIRECTLY TO VINTAGE AIR WITHIN 15 DAYS. AFTER 15 DAYS, VINTAGE AIR WILL NOT BE RESPONSIBLE FOR MISSING OR DAMAGED ITEMS.**

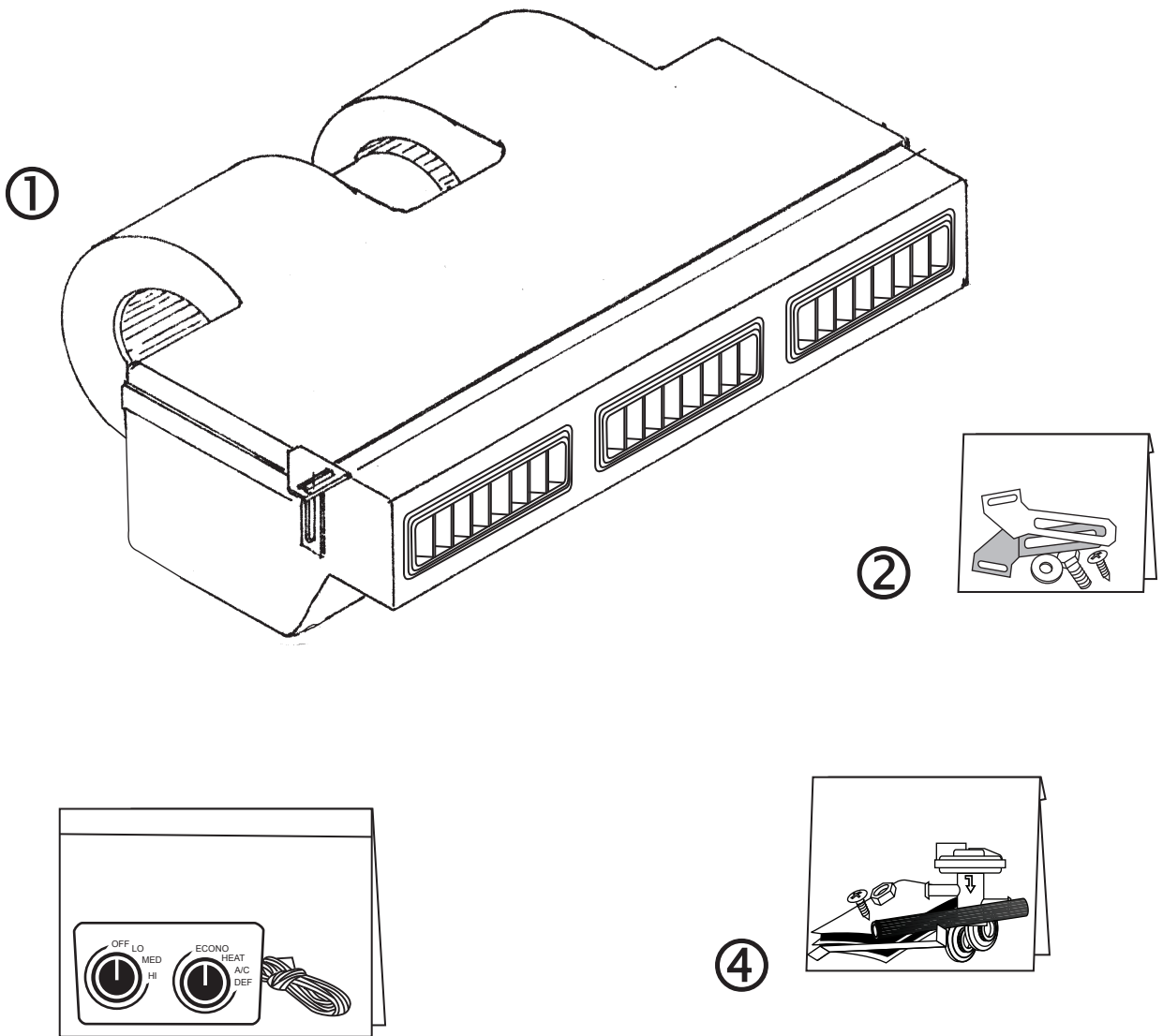

NOTE: IMAGES MAY NOT DEPICT ACTUAL PARTS AND QUANTITIES. REFER TO PACKING LIST FOR ACTUAL PARTS AND QUANTITIES.



MINI SLIMLINE COOL

MINI SLIMLINE COOL

IMPORTANT NOTICE-PLEASE READ

FOR MAXIMUM SYSTEM PERFORMANCE VINTAGE AIR RECOMMENDS THE FOLLOWING:

THIS KIT DOES NOT CONTAIN HEATER HOSE. YOU MUST PURCHASE 8 FEET OF 5/8" DIA. HEATER HOSE FROM VINTAGE AIR(31800-VUD) OR FROM YOUR LOCAL PARTS RETAILER.

SAFETY SWITCHES:

A COMPRESSOR SAFETY SWITCH MUST BE INSTALLED ON EVERY A/C SYSTEM. A BINARY SWITCH DISENGAGES THE COMPRESSOR CLUTCH IN CASES OF EXTREME LOW PRESSURE (REFRIGERANT LOSS) OR EXCESSIVELY HIGH HEAD PRESSURE (406 PSI) TO PREVENT COMPRESSOR DAMAGE OR HOSE RUPTURE. A TRINARY SWITCH COMBINES HI/LO PRESSURE PROTECTION WITH AN ELECTRIC FAN OPERATION SIGNAL AT 254 PSI. COMPRESSOR SAFETY SWITCHES ARE EXTREMELY IMPORTANT SINCE AN A/C SYSTEM RELIES ON REFRIGERANT TO CARRY LUBRICATION THROUGH THE SYSTEM.

SERVICE INFO:

ATTENTION: SYSTEM COMPONENTS: THE COMPRESSOR, EVAPORATOR, CONDENSER & DRIER ARE CAPPED. CAPS MAY BE UNDER PRESSURE WITH DRY NITROGEN; BE CAREFUL REMOVING CAPS. DO NOT REMOVE CAPS PRIOR TO INSTALLATION. REMOVING CAPS PRIOR TO INSTALLATION WILL CAUSE COMPONENTS TO COLLECT MOISTURE AND LEAD TO PREMATURE FAILURE AND REDUCED PERFORMANCE.

EVACUATE THE SYSTEM FOR 35-45 MINUTES WITH SYSTEM COMPONENTS (DRIER, COMPRESSOR, EVAPORATOR AND CONDENSER) AT A TEMPERATURE OF AT LEAST 85° F. ON A COOL DAY THE COMPONENTS CAN BE HEATED WITH A HEAT GUN OR BY RUNNING THE ENGINE WITH THE HEATER ON BEFORE EVACUATING. LEAK CHECK AND CHARGE TO SPECIFICATIONS.

VINTAGE AIR SYSTEMS ARE DESIGNED TO OPERATE WITH R134a REFRIGERANT ONLY! USE OF ANY OTHER REFRIGERANTS IS A FIRE HAZARD AND COULD DAMAGE EITHER YOUR AIR CONDITIONING SYSTEM OR YOUR VEHICLE.

USE OF ANY OTHER REFRIGERANTS WILL VOID ALL WARRANTIES OF THE AIR CONDITIONING SYSTEM AND COMPONENTS. USE OF THE PROPER TYPE AND AMOUNT OF REFRIGERANT IS CRITICAL TO PROPER SYSTEM OPERATION. VINTAGE AIR RECOMMENDS OUR SYSTEMS BE CHARGED BY WEIGHT WITH A QUALITY CHARGING STATION OR SCALE.

REFRIGERANT CAPACITIES FOR VINTAGE AIR SYSTEMS

(FOR OTHER SYSTEMS, CONSULT MANUFACTURER GUIDELINES)

134a SYSTEM

CHARGE WITH 1.8 lbs.
(1lbs. 12ozs) OF REFRIGERANT

LUBRICANT CAPACITIES: NEW COMPRESSOR - NO ADDITIONAL OIL NEEDED
USED COMPRESSOR - CONSULT VINTAGE AIR

INSTALLATION

1. ATTACH EVAPORATOR BRACKETS TO EVAPORATOR.
2. DRILL (2) 9/32" HOLES UNDER THE DASH LIP WITH EVAPORATOR BRACKETS ATTACHED TO EVAPORATOR AS SHOWN IN FIGURE 1, BELOW.

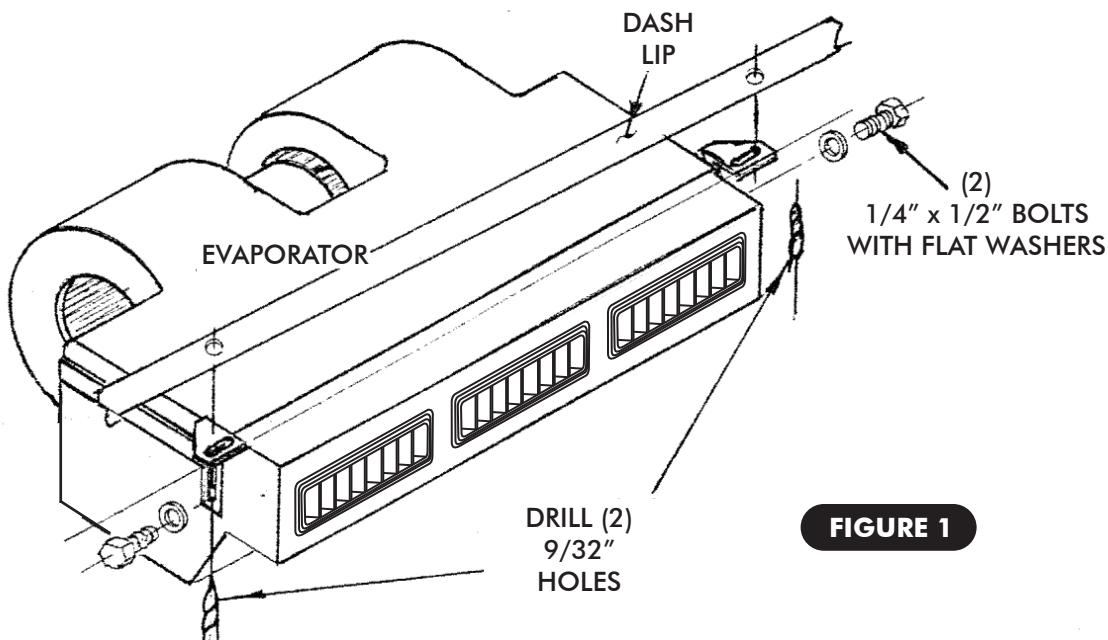

FIGURE 1

3. ATTACH THE EVAPORATOR TO THE DASH WITH (2) 1/4" x 1" BOLTS AND NUTS AS SHOWN IN FIGURE 2, BELOW.
4. ATTACH THE DRAIN HOSE AS SHOWN IN FIGURE 2, BELOW.

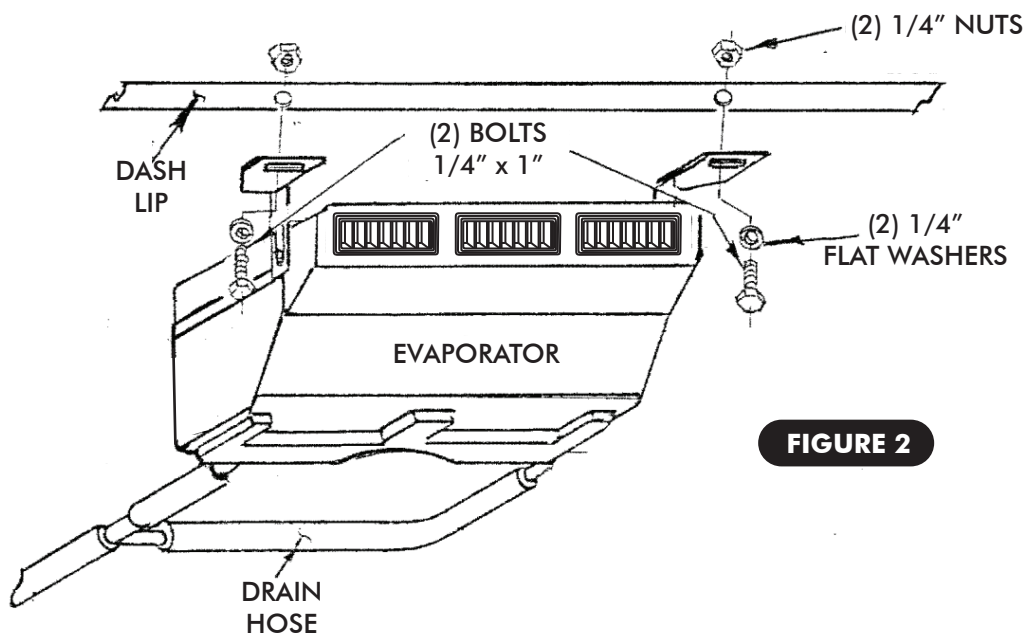

FIGURE 2



INSTALLATION (CONTINUED)

- PUSH THE 5/16" I.D. HOSE ONTO THE STRAIGHT #6 FITTING. (SEE HOSE ROUTING ILLUSTRATION ON PG. 7). INSTALL THE FITTING ONTO THE EXPANSION VALVE (FINGER TIGHT). PUSH THE 1/2" I.D. HOSE ONTO THE STRAIGHT #10 FITTING, AND INSTALL THE FITTING ONTO THE #10 LINE ON THE EVAPORATOR (SEE HOSE ROUTING ILLUSTRATION PG. 7).
- AT THIS TIME, TRY TO DETERMINE WHERE YOU WANT YOUR LINES TO GO THROUGH THE FIREWALL. MOVE THE HOSES TO THAT POINT. HOLD THE FITTINGS UP TO THEIR RESPECTIVE HOSES, AND DETERMINE IF THE HOSES WILL CONFORM TO THE LOCATION FOR THE BULKHEAD FITTINGS OR OPTIONAL BULKHEAD PLATE (VINTAGE AIR PART #34215-VUQ OR 34217-VUQ). THE 1/2" HOSE IS HARD TO BEND AT A SHARP ANGLE, AND THE FITTINGS TAKE UP A CERTAIN AMOUNT OF SPACE. BEFORE YOU DRILL HOLES IN YOUR FIREWALL, MAKE SURE THAT YOU CAN MAKE THE HOSES FIT WHERE YOU HAVE PLANNED. THE ENGINE COMPARTMENT APPEARANCE IS A CONSIDERATION WHEN CHOOSING THIS LOCATION.
- WHEN YOU HAVE DECIDED WHERE YOU WANT TO PLACE YOUR BULKHEAD FITTINGS, MARK THESE POINTS WITH A GREASE PENCIL AND MAKE A TEMPLATE FROM THE INSIDE, LOCATING WHERE THE HOLES WILL BE CUT. WITH THIS TEMPLATE, LOCATE THE SAME POINTS ON THE OUTSIDE OF THE FIREWALL. MARK THESE POINTS WITH A GREASE PENCIL.
- DETERMINE THE BEST LOCATION FOR THE DRIER THAT WILL ALLOW ADEQUATE ROOM FOR THE HOSE AND FITTINGS THAT CONNECT THE DRIER TO THE BULKHEAD FITTING.
- MOUNT THE DRIER (KEEP THE DRIER CAPPED AS MUCH AS POSSIBLE. IF YOU MUST SCREW THE FITTING TO THE DRIER, TAPE IT CLOSED).

NOTE: THE DRIER IS USUALLY MOUNTED WHERE YOU HAVE ROOM FOR IT. JUST REMEMBER TO MOUNT IT IN THE COOLEST SPOT POSSIBLE, AND VERTICALLY SO THE SIGHT GLASS IS DIRECTLY ON TOP (NOT NEXT TO THE EXHAUST MANIFOLD). IT CAN BE MOUNTED INSIDE THE VEHICLE AS WELL.

- AT THIS POINT, CUT HOLES FOR BULKHEAD FITTINGS, AND INSTALL THEM.
- USING THE HOSE ROUTING ILLUSTRATION AS A GUIDE, ROUTE REMAINING A/C LINES, AND CUT TO LENGTH.
- INSTALL A/C VENTS THAT WILL BE USED AT THIS TIME.
- CENTER OUTLET: YOU MAY USE THE CENTER PANEL FURNISHED, OR YOU CAN MOUNT THE VENTS IN DASH. IF YOU USE THE CONTROL PANEL, THE TOP MOUNTING LIPS SHOULD BE BACK 1/4" X 1/2" FROM LOWER LEADING EDGE OF DASH. LOCATE THE 2 1/2" I.D. HOSE, AND ROUTE FROM THE DASH VENTS TO THE EVAPORATOR.
- AT THIS TIME, YOU SHOULD HAVE THE REFRIGERATION HOSES CUT TO THEIR PROPER LENGTH. **PAY CLOSE ATTENTION TO THE ORIENTATION OF ANY HOSE WITH TWO ANGLED FITTINGS.** ANY HOSE WITH TWO ANGLED FITTINGS MUST BE MARKED FROM THE HOSE TO THE FITTINGS TO ASSURE THEY WILL REMAIN IN THIS POSITION AFTER CRIMPING. THE RUBBER HOSE IS ONLY CAPABLE OF A MINIMAL AMOUNT OF TWIST TO AID ALIGNMENT.
- REMOVE HOSES AND CRIMP ENDS. IF YOU DO NOT HAVE ACCESS TO THE PROPER EQUIPMENT, VINTAGE AIR RECOMMENDS TAKING THEM TO A QUALIFIED A/C SERVICE CENTER FOR CRIMPING (SEE CRIMPING INSTRUCTIONS SUPPLIED WITH THE HOSE KIT).
- WITH THE EVAPORATOR TRIAL FIT COMPLETE, REMOVE THE UNIT AND LOWER INTO THE VEHICLE.
- AFTER CRIMPING HOSES, LOCATE THE #6 A/C HOSE WITH THE STRAIGHT FITTING. LUBRICATE A #6 A/C O-RING AND THE THREADS ON THE FITTING, AND INSTALL ON THE EXPANSION VALVE. TIGHTEN CAREFULLY. REFER TO FIGURES 3 & 3a, PAGE 8.
- LOCATE THE #10 A/C HOSE WITH THE STRAIGHT FITTING. LUBRICATE A #10 O-RING AND THE THREADS ON THE FITTING, AND INSTALL ON THE #10 LINE OF THE EVAPORATOR. TIGHTEN CAREFULLY. REFER TO FIGURES 3 & 3a, PAGE 8.
- WRAP THE #10 FITTING WITH PRESS TAPE, AND COVER ALL EXPOSED METAL SURFACES. (DO NOT WRAP THE #6 HOSE, FITTING, OR THE HEATER CORE TUBES). SEE FIGURE 3, PAGE 8.



MINI SLIMLINE COOL

TYPICAL HOSE ROUTING DIAGRAM

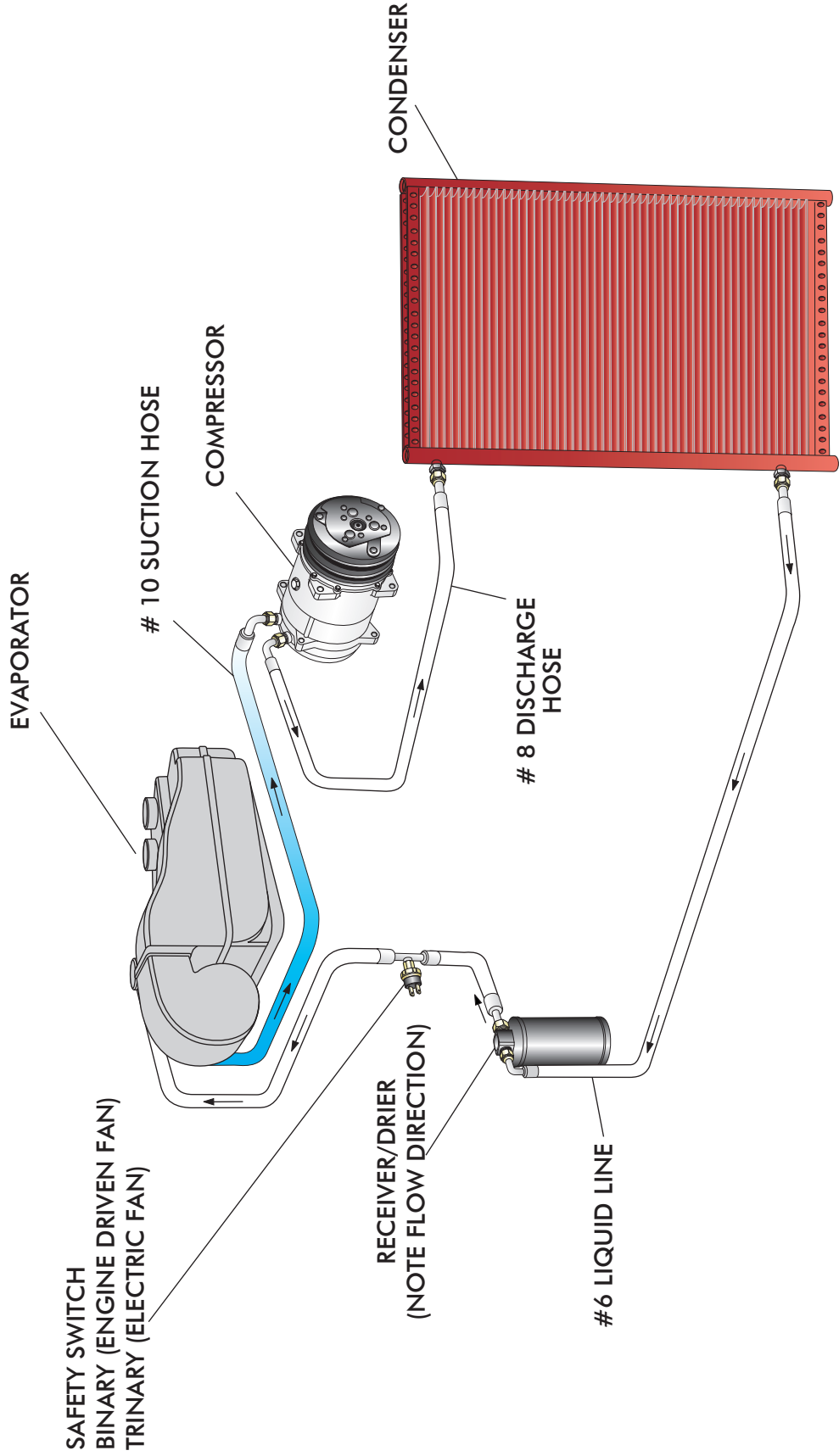

DIRECTION OF REFRIGERANT FLOW INDICATED BY ARROWS

O-RING/FITTING INSTRUCTIONS

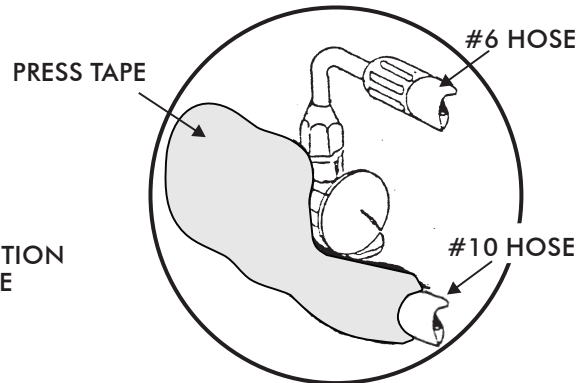
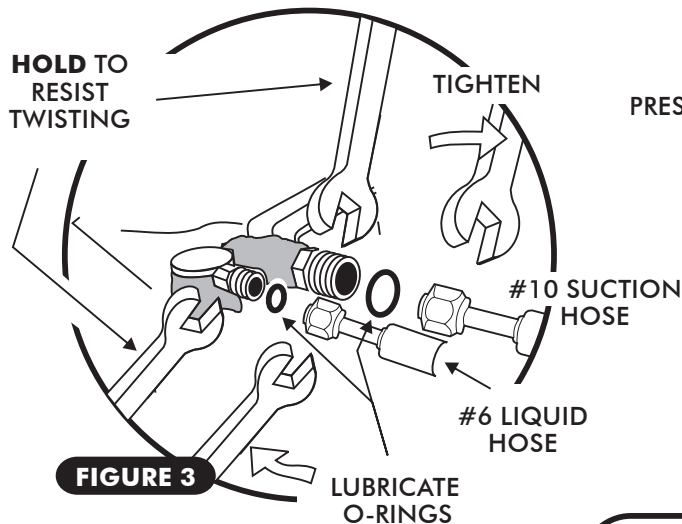

FOR A PROPER SEAL OF FITTINGS INSTALL SUPPLIED O-RINGS AS SHOWN AND LUBRICATE WITH SUPPLIED OIL.

O-RING, SLIDE OVER MALE INSERT TO SWAGED LIP

SUPPLIED OIL FOR O-RINGS



FIGURE 3A

- MAKE ELECTRICAL CONNECTIONS, ACCORDING TO THE DIAGRAM FURNISHED ON PG. 9.
- NOTE: THE RED 12GA. WIRE WITH THE 30 AMP CIRCUIT BREAKER SHOULD BE CONNECTED TO A 12 VOLT POWER SOURCE OF AT LEAST 12GA. WIRE. CONNECT MOLDED PLUG WITH THE (RED, YELLOW, ORANGE) WIRES TO THE CORRESPONDING PLUG FROM THE BLOWER MOTOR. THE SINGLE BLACK WIRE FROM THE BLOWER MOTOR MUST BE GROUNDED. THE BLUE CLUTCH WIRE RUNS FROM THE THERMOSTAT TO THE COMPRESSOR SAFETY SWITCH AND FROM THE SAFETY SWITCH TO THE COMPRESSOR.

BE CAREFUL TO ENSURE THAT THIS WIRE IS NOT PINCHED OR IN A POSITION TO RUB ON A SHARP EDGE AS IT GOES THROUGH THE FIREWALL.



WIRING DIAGRAM COOL

**(REQUIRED)
COMPRESSOR
SAFETY SWITCH
(BINARY TYPE)**

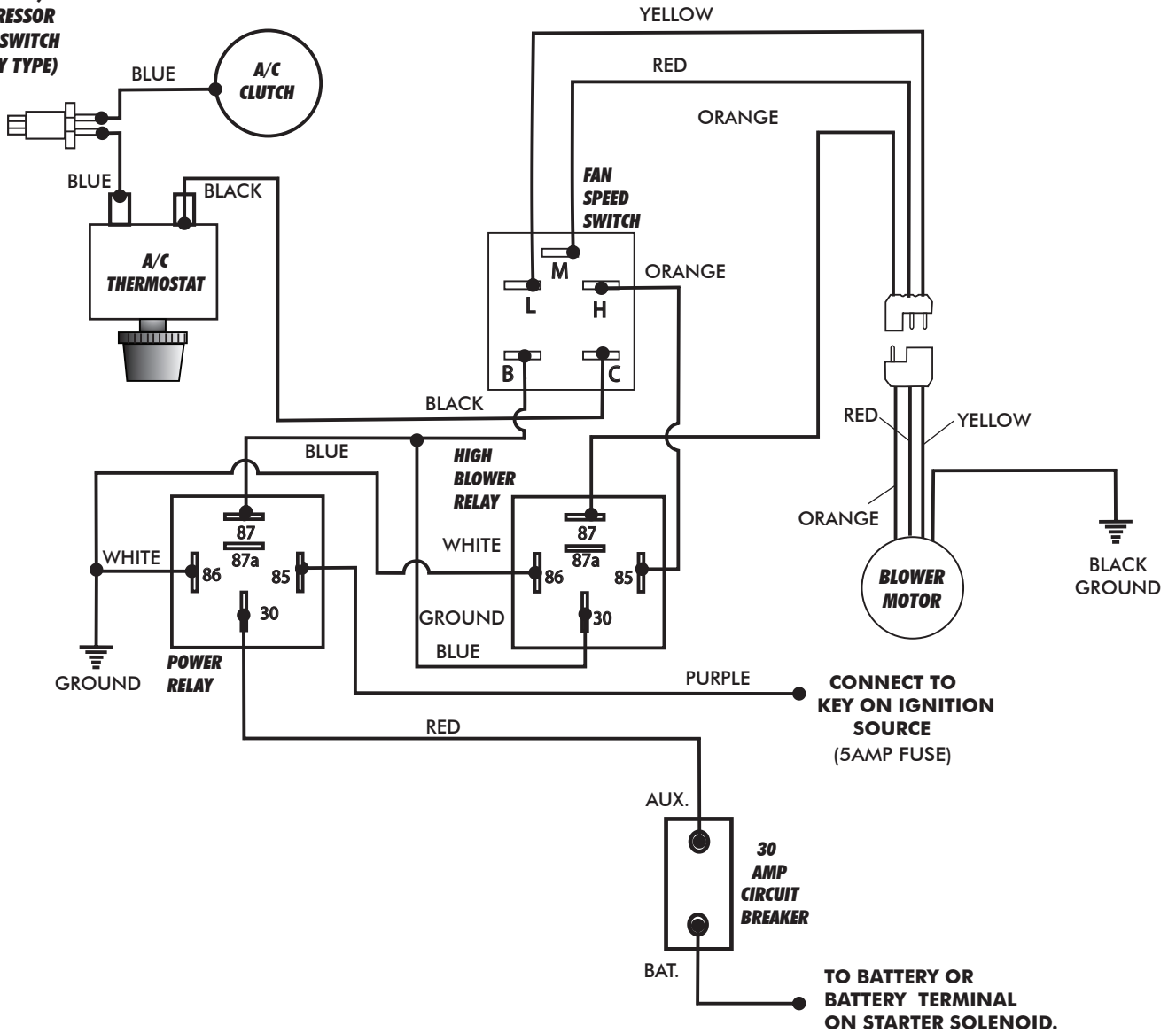

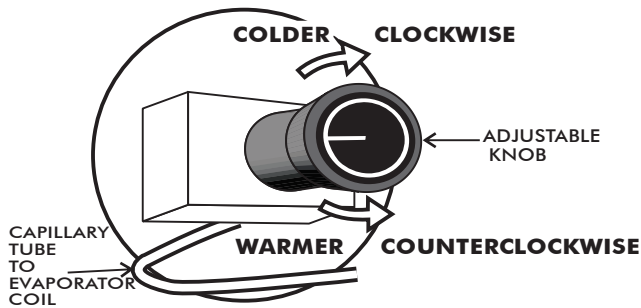

AIR CONDITIONING ADJUSTMENTS:

- THE AIR CONDITIONER THERMOSTAT CONTROLS COIL TEMPERATURE. THERMOSTATS ARE SHIPPED ADJUSTED FULLY COLD (CLOCKWISE), AND IN THE MAJORITY OF CASES, THE A/C WILL OPERATE CORRECTLY AS SHIPPED.
- TURNING THE KNOB TO THE RIGHT (CLOCKWISE) MAKES THE SYSTEM OPERATE COLDER. IF THE THERMOSTAT IS SET TOO COLD, THE EVAPORATOR COIL WILL "ICE UP," MEANING THE EVAPORATOR COIL IS RESTRICTED WITH ICE, AND COLD AIR FLOW WILL BE REDUCED.
- TURNING THE KNOB TO THE LEFT (COUNTERCLOCKWISE) MAKES THE SYSTEM OPERATE WARMER. THE COMPRESSOR CLUTCH WILL CYCLE OFF FREQUENTLY. THE EVAPORATOR COIL WILL NOT GET AS COLD, AND THE TEMPERATURE WILL NOT BE AS COLD.

ADJUSTING A/C THERMOSTAT

- 1.) **SYMPTOM:** THE A/C WORKS WELL AT FIRST, THEN QUILTS COOLING. THE AIRFLOW FROM THE VENTS IS LOW, AND THE COMPRESSOR CLUTCH CYCLES INFREQUENTLY.
SOLUTION: THE THERMOSTAT IS SET TOO COLD AND THE EVAPORATOR IS "ICING UP" AND RESTRICTING AIRFLOW. ALLOW THE ICE TO MELT AND SET THE THERMOSTAT WARMER (COUNTERCLOCKWISE) 1/8 OF TURN EACH ADJUSTMENT UNTIL THE SYMPTOMS DIMINISH.
- 2.) **SYMPTOM:** A/C NEVER GETS COLD AND THE COMPRESSOR CLUTCH CYCLES FREQUENTLY.
SOLUTION: THE THERMOSTAT IS SET TOO WARM. SET THE THERMOSTAT COLDER (CLOCKWISE) 1/8 OF A TURN EACH ADJUSTMENT, UNTIL THE DESIRED AIR TEMPERATURE IS REACHED. **AVOID SETTING THE THERMOSTAT TOO COLD.**



MINI SLIMLINE COOL

EVAPORATOR KIT
 10301-VUY-A
 10401-VUY-A

EVAPORATOR KIT PACKING LIST

No.	QTY.	PART No.	DESCRIPTION	
1.	1	55325-VUE-A	EVAPORATOR SUB CASE COOL ONLY w/ STD LOUVERS	_____
		55425-VUE-A	EVAPORATOR SUB CASE COOL ONLY w/ BLK LOUVERS	_____
2.	1	64143-VUE	EVAPORATOR MOUNTING BRKT. KIT	_____
3.	1	49140-VUY	CONTROL POD W/ WIRING	_____
4.	1	63301-VUE	INSTALLATION KIT (COOL ONLY)	_____

CHECKED BY: _____
 PACKED BY: _____
 DATE: _____

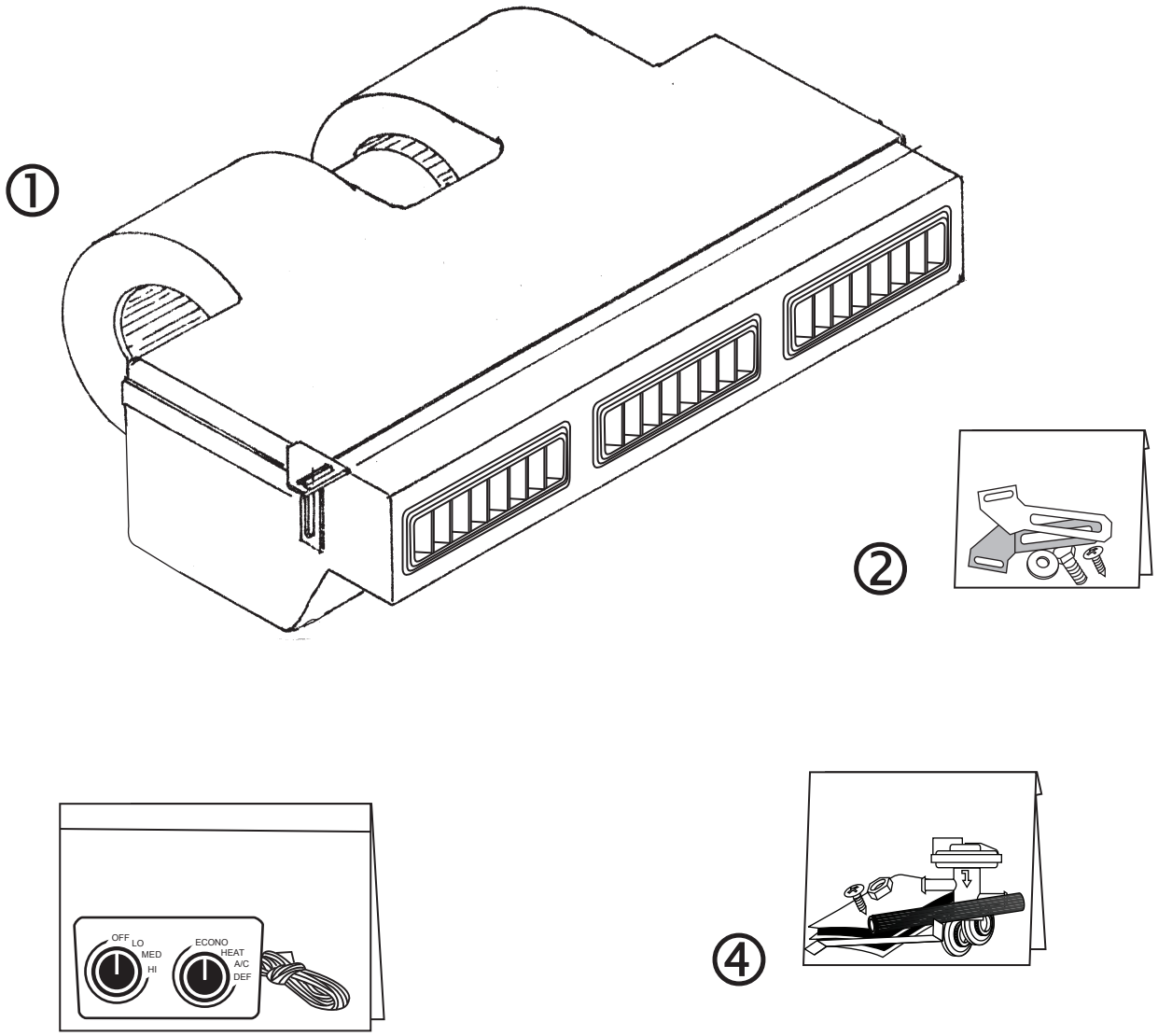

**NOTE: IMAGES MAY NOT DEPICT ACTUAL PARTS AND QUANTITIES.
 REFER TO PACKING LIST FOR ACTUAL PARTS AND QUANTITIES.**