

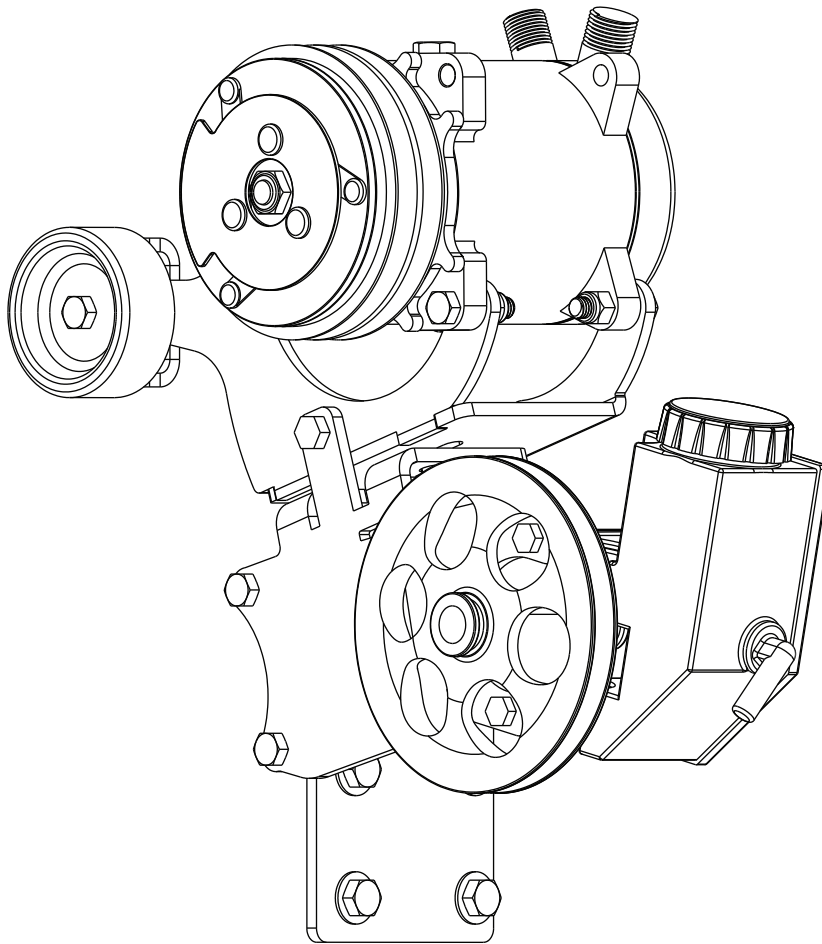

# 300 16

**T.C. (Type II) Power Steering Pump Add-on  
Bracket Kit  
(137141)**

**Driver Side  
Fits Most: 1980-86 Ford F-Series/Broncos**



**18865 Goll St. San Antonio, TX 78266  
Phone: 800-862-6658  
Sales: sales@vintageair.com  
Tech Support: tech@vintageair.com  
www.vintageair.com**



www.vintageair.com

# Table of Contents

Cover.....	1
Table of Contents.....	2
Packing List/Parts Disclaimer.....	3
Important Notice.....	4
Bracket Installation.....	5
Compressor Warnings.....	6
Packing List.....	7

## Additional Info: Please Read Before Beginning

- This kit requires compressor bracket kit (137127) for mounting.
- Due to the wide range of accessory options and pulley diameters, you will need to measure your pulleys to get the proper length V-belts.
- Some modifications or replumbing of pressure and return lines will be required to retrofit to some engines.

## Additional Parts & Accessories

- This kit is designed to work with Vintage Air part numbers 851001 - Power steering pump with integral reservoir or 851002 - Power steering pump without reservoir.
- The power steering pulley is designed for pumps with .6647" shaft diameters.

**851001**

Power Steering Pump with Reservoir



**722050**

Aluminum Power Steering Reservoir



**851002**

Power Steering Pump without Reservoir





www.vintageair.com

## Packing List: Add-on Bracket Kit (137141)

No.	Qty.	Part No.	Description
1.	1	137119	Bracket, Power Steering T.C. Pump
2.	1	191132	Hardware Kit
3.	1	730011	Pulley, 6"

**\*\* Before beginning installation, open all packages and check contents of shipment. Please report any shortages directly to Vintage Air within 15 days. After 15 days, Vintage Air will not be responsible for missing or damaged items.**

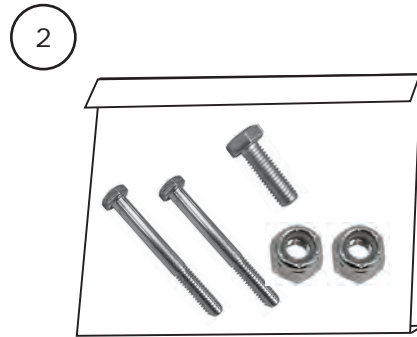

**NOTE: Images may not depict actual parts and quantities.  
Refer to packing list for actual parts and quantities.**



www.vintageair.com

## Important Notice—Please Read

*For Maximum System Performance, Vintage Air Recommends the Following:*

**NOTE:** Vintage Air systems are designed to operate with R134a refrigerant only. Use of any other refrigerant could damage your A/C system and/or vehicle, and possibly cause a fire, in addition to potentially voiding the warranties of the A/C system and its components.

### Refrigerant Capacities:

**Vintage Air System:** 1.8 lbs. (28.8 oz.) or 816 grams of **R134a**, charged by weight with a quality charging station or scale. **NOTE: Use of the proper type and amount of refrigerant is critical to system operation and performance.**

**Other Systems:** Consult manufacturer's guidelines.

### Lubricant Capacities:

**New Vintage Air-Supplied Sanden Compressor:** No additional oil needed (Compressor is shipped with proper oil charge).

**All Other Compressors:** Consult manufacturer (Some compressors are shipped dry and will need oil added).

### Safety Switches

Your Vintage Air system is equipped with a binary pressure safety switch. A binary switch disengages the compressor clutch in cases of extreme low pressure conditions (refrigerant loss) or excessively high head pressure (406 PSI) to prevent compressor damage or hose rupture. A trinary switch combines Hi/Lo pressure protection with an electric fan operation signal at 254 PSI, and should be substituted for use with electric fans. Compressor safety switches are extremely important since an A/C system relies on refrigerant to circulate lubricant.

### Service Info:

**Protect Your Investment:** Prior to assembly, it is critical that the compressor, evaporator, A/C hoses and fittings, hardlines, condenser and receiver/drier remain capped. Removing caps prior to assembly will allow moisture, insects and debris into the components, possibly leading to reduced performance and/or premature failure of your A/C system. This is especially important with the receiver/drier.

Additionally, when caps are removed for assembly, **BE CAREFUL!** Some components are shipped under pressure with dry nitrogen.

**Evacuate the System for 35-45 Minutes:** Ensure that system components (Drier, compressor, evaporator and condenser) are at a temperature of at least 85°F. On a cool day, the components can be heated with a heat gun **or** by running the engine with the heater on before evacuating. Leak check and charge to specifications.

### Bolts Passing Through Cowl and/or Firewall:

To ensure a watertight seal between the passenger compartment and the vehicle exterior, for all bolts passing through the cowl and/or firewall, Vintage Air recommends coating the threads with silicone prior to installation.

### Heater Hose (not included with this kit):

Heater hose may be purchased from Vintage Air (Part#31800-VUD) or your local parts retailer. Routing and required length will vary based on installer preference.

## Bracket Installation

**NOTE:** The power steering T.C. pump bracket (137119) installs in the place of the power steering bracket (137118) included with the 300 1980-86 Ford F-Series/Bronco compressor bracket kit (137127). Refer to the compressor bracket instructions for more details.

1. Attach the T.C. pump to the power steering T.C. pump bracket using (2) 5/16-18 x 2 3/4" hex bolts and (2) 5/16-18 locknuts into the top and bottom holes (See Figure 1, below), then thread the 8MM 1.25 x 25MM hex bolt into the left side hole (See Figure 1, below).
2. Install the 6" pulley onto the pump using an appropriate power steering pulley install tool. **NOTE: Ensure that the groove of the power steering pulley is in line with the rear groove closest to the engine of the compressor.**
3. Refer to the compressor bracket kit instructions (137127) for belt routing.

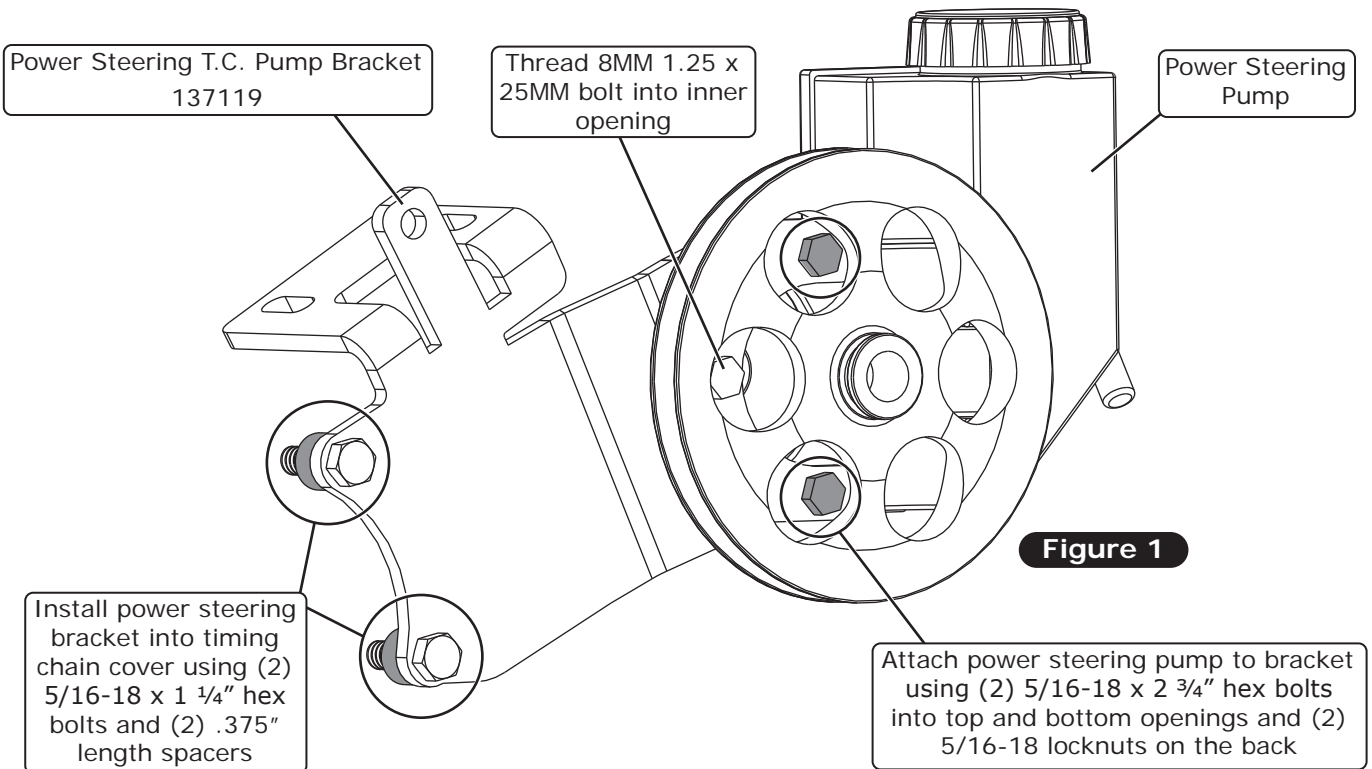

**Figure 1**

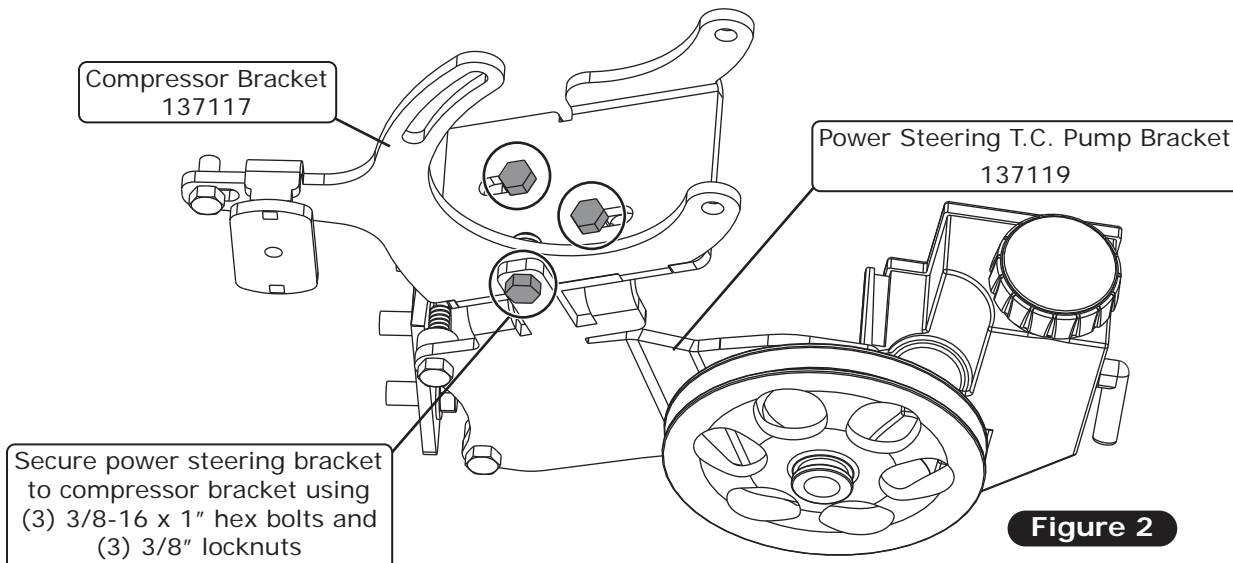

**Figure 2**



www.vintageair.com

## Compressor Warnings

**NOTE:** Failure to follow these procedures may void all warranties.

1. With compressor kit installed, and belt tightened, check angle of oil plug on compressor. As shown below, oil plug must not exceed 90° beyond vertical centerline.
2. Do not connect compressor clutch wire until system is being charged with refrigerant. Running compressor without refrigerant charge may result in compressor failure.

### IMPORTANT NOTICE:

- Do not connect compressor clutch wire until system is being charged with refrigerant. Since an A/C system relies on refrigerant to circulate lubricant, running the compressor without refrigerant may destroy the compressor and void the warranty.
- Proper compressor orientation is important. Sanden compressors may be rotated from vertical (oil fill plug at top) up to 90° in either direction (See illustration).

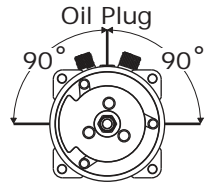





www.vintageair.com

## Packing List: Add-on Bracket Kit (137141)

No.	Qty.	Part No.	Description
1.	1	137119	Bracket, Power Steering T.C. Pump
2.	1	191132	Hardware Kit
3.	1	730011	Pulley, 6"

Checked By: \_\_\_\_\_  
 Packed By: \_\_\_\_\_  
 Date: \_\_\_\_\_

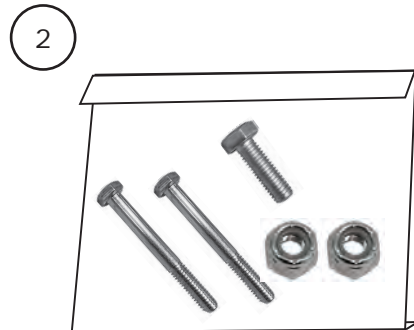

**NOTE: Images may not depict actual parts and quantities.  
Refer to packing list for actual parts and quantities.**