

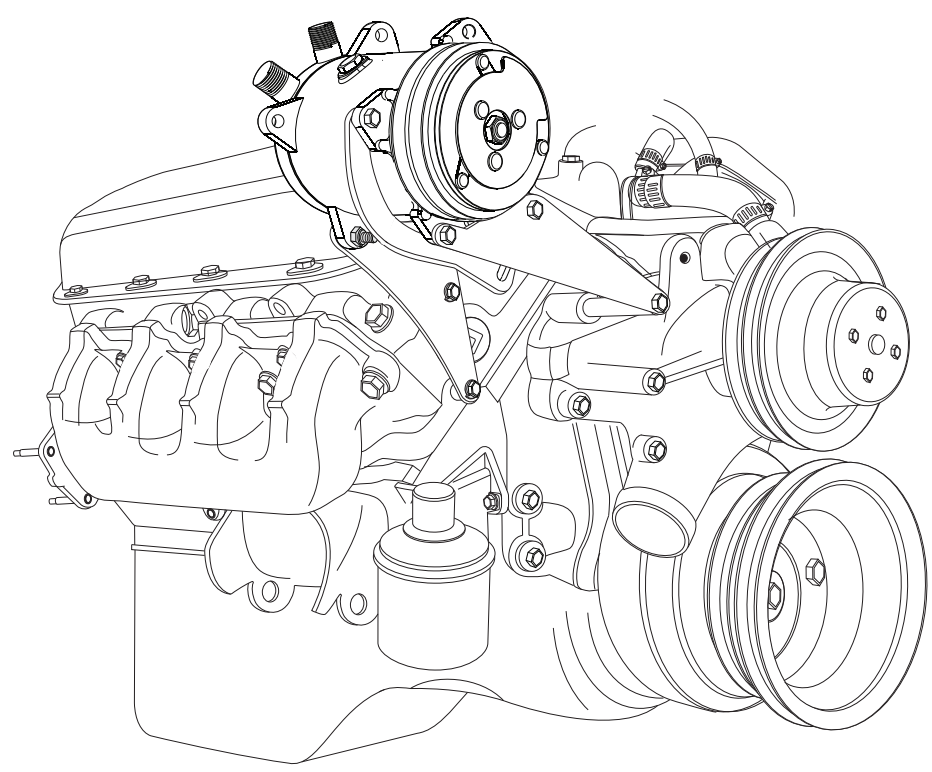

BIG BLOCK CHEVY

**COMPRESSOR BRACKET
WITH AND WITHOUT POWER STEERING
LONG PUMP PASSENGER SIDE**



151371-BCA

18865 GOLL ST. - SAN ANTONIO, TX. - 78266 ph.210-654-7171 - fax 210-654-3113



**BIG BLOCK CHEVY POWER STEERING LONG PUMP
PASSENGER SIDE COMPRESSOR BRACKET**

Table of Contents

PAGES

1. COVER
2. TABLE OF CONTENTS
3. PACKING LIST
4. REAR COMPRESSOR MOUNTING BRACKET INSTALLATION
5. COMPRESSOR MOUNTING BRACKET
6. COMPRESSOR INSTALLATION
7. BELT ROUTING
8. PACKING LIST



**BIG BLOCK CHEVY POWER STEERING LONG PUMP
PASSENGER SIDE COMPRESSOR BRACKET**

**BIG BLOCK CHEVY POWER STEERING LONG PUMP
PASSENGER SIDE COMPRESSOR BRACKET**

(151371-BCA) PACKING LIST

No.	QTY.	PART No.	DESCRIPTION
1.	1	146006-SCR	COMPRESSOR MOUNTING BRKT
2.	1	156137-BCR	BBC LP REAR COMP BRKT
3.	1	156138-BCR	BBC LP FRNT MNTG BRKT
4.	1	191138-HCA	HARDWARE KIT

**** BEFORE BEGINNING INSTALLATION, OPEN ALL PACKAGES AND CHECK CONTENTS OF SHIPMENT. PLEASE REPORT ANY SHORTAGES DIRECTLY TO VINTAGE AIR WITHIN 15 DAYS. AFTER 15 DAYS, VINTAGE AIR WILL NOT BE RESPONSIBLE FOR MISSING OR DAMAGED ITEMS.**

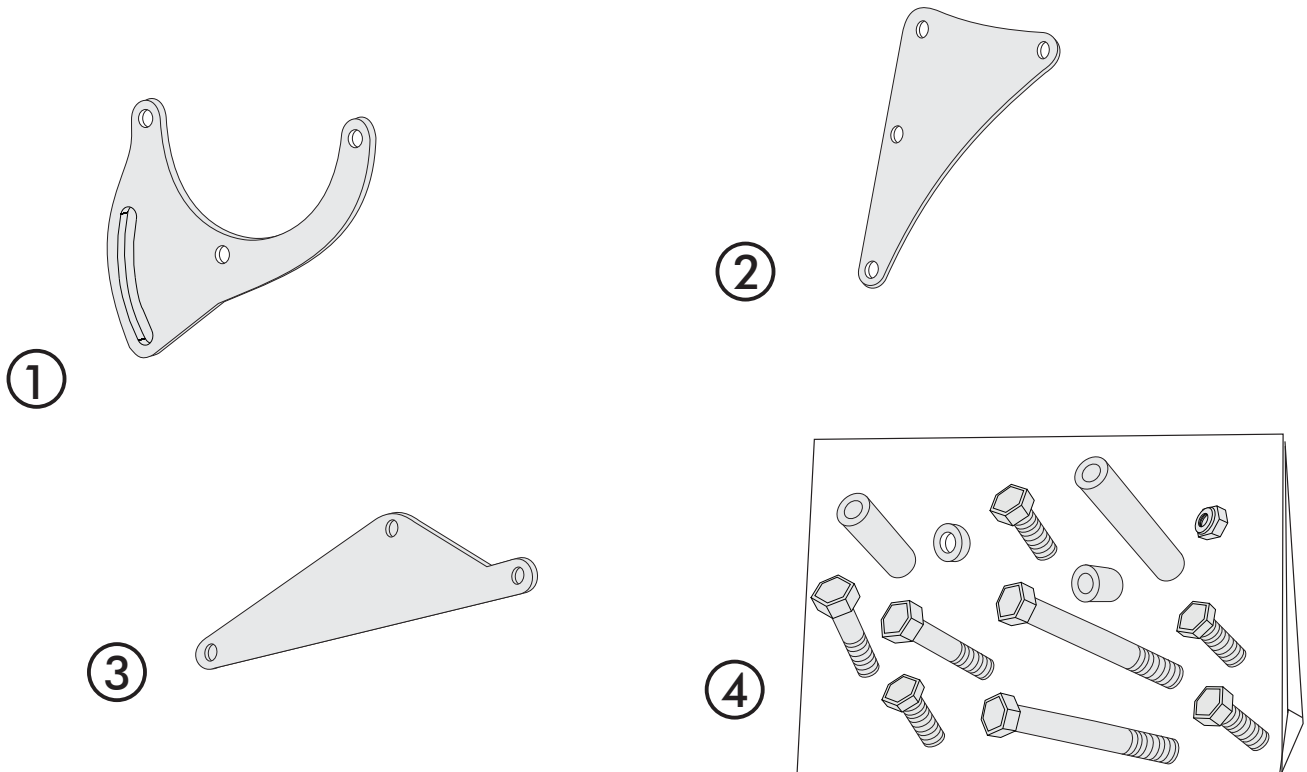



BIG BLOCK CHEVY POWER STEERING LONG PUMP PASSENGER SIDE COMPRESSOR BRACKET

INSTALLATION INSTRUCTIONS

COMPRESSOR MOUNTING BRACKET ASSEMBLY INSTALLATION

- IF EQUIPPED, REMOVE THE OEM A/C COMPRESSOR AND BRACKET. (DISCARD)
- INSTALL THE REAR COMPRESSOR BRACKET AS SHOWN BELOW IN FIGURE 1. PLACE THE (2) .750" STEEL SPACERS BETWEEN THE BRACKET AND THE HEAD. SECURE THE BRACKET USING (2) 3/8-16 x 1 1/2" HEX BOLTS w/ LOCK WASHERS. **NOTE: SOME HEADS HAVE 3/8" BOLT HOLES AND SOME HAVE 7/16" BOLT HOLES. THIS KIT INCLUDES BOTH SIZES OF BOLTS. IF YOUR HEADS HAVE 7/16" BOLT HOLES, YOU MUST ENLARGE THE CORRESPONDING HOLES IN THE MOUNTING BRACKETS TO 7/16". USE THE 7/16-14 x 1 1/2" HEX BOLTS TO SECURE BRACKET.**

NOTE: ASSEMBLE ALL BRACKETS LOOSELY TO ENGINE BEFORE TIGHTENING BOLTS. THIS WILL ENSURE PROPER ALIGNMENT OF ALL BRACKETS.

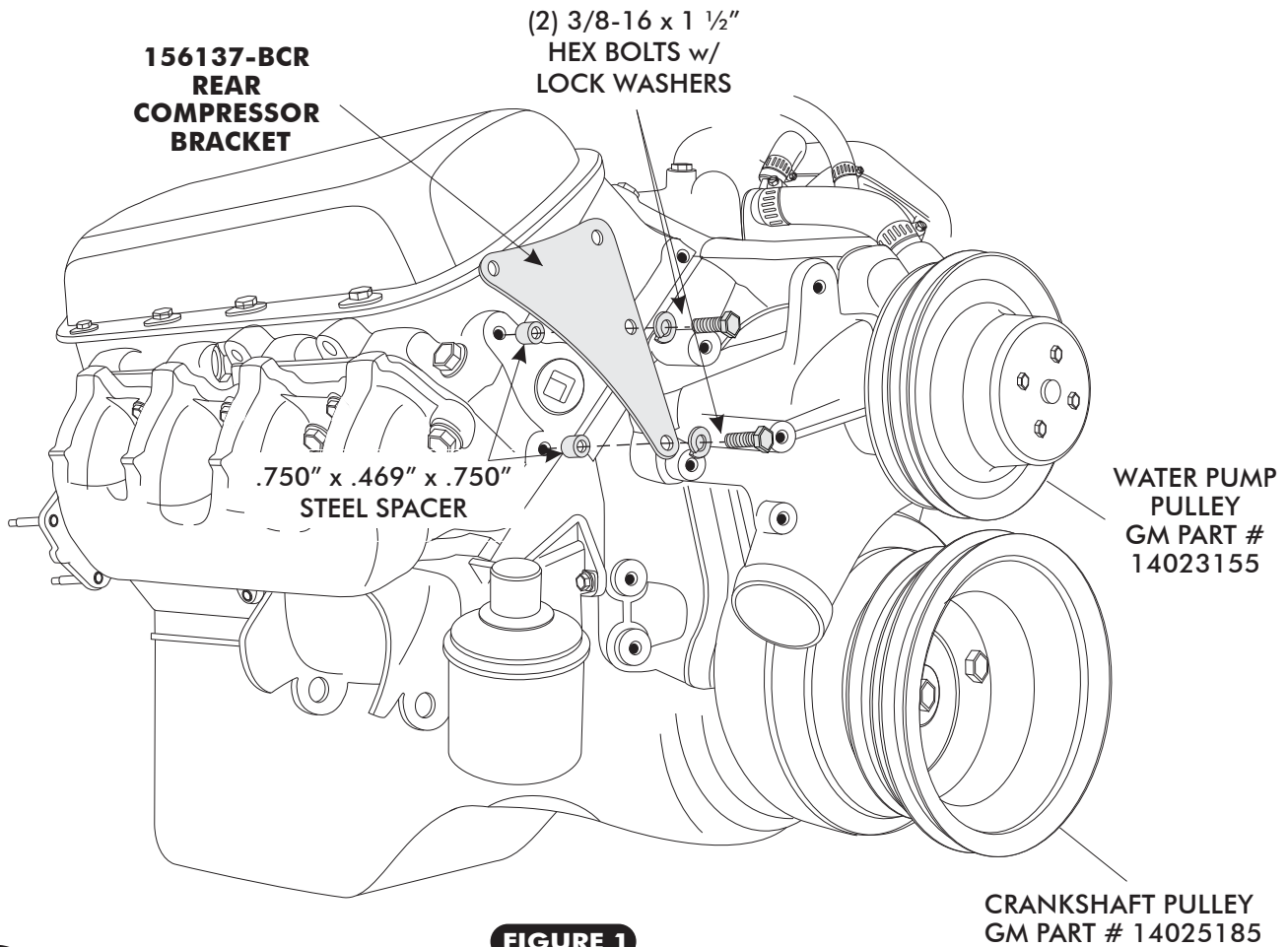

FIGURE 1



BIG BLOCK CHEVY POWER STEERING LONG PUMP PASSENGER SIDE COMPRESSOR BRACKET

COMPRESSOR MOUNTING BRACKET INSTALLATION

- INSTALL THE FRONT COMPRESSOR MOUNTING BRACKET AS SHOWN IN FIGURE 2, BELOW. SECURE USING A 3/8-16 x 5" HEX BOLT w/ LOCK WASHER AND 2.500" SPACER THROUGH THE TOP WATER PUMP MOUNTING HOLE.
- WITH THE FRONT MOUNTING BRACKET INSTALLED, INSTALL THE COMPRESSOR MOUNTING BRACKET AS SHOWN BELOW IN FIGURE 2. SECURE THE BRACKET USING THE 3/8-16 x 4 1/2" HEX BOLT, INSTALL THE BOLT THROUGH THE FRONT MOUNTING BRACKET, THEN INSTALL THE .563" SPACER OVER BOLT. ALIGN THE COMPRESSOR MOUNTING BRACKET ADJUSTER SLOT AND SLIDE THE BOLT THROUGH THE BRACKET. INSTALL THE 2.770" SPACER OVER THE BOLT AND THREAD THE BOLT INTO THE REAR MOUNTING BRACKET AS SHOWN. SEE FIGURE 2 BELOW.

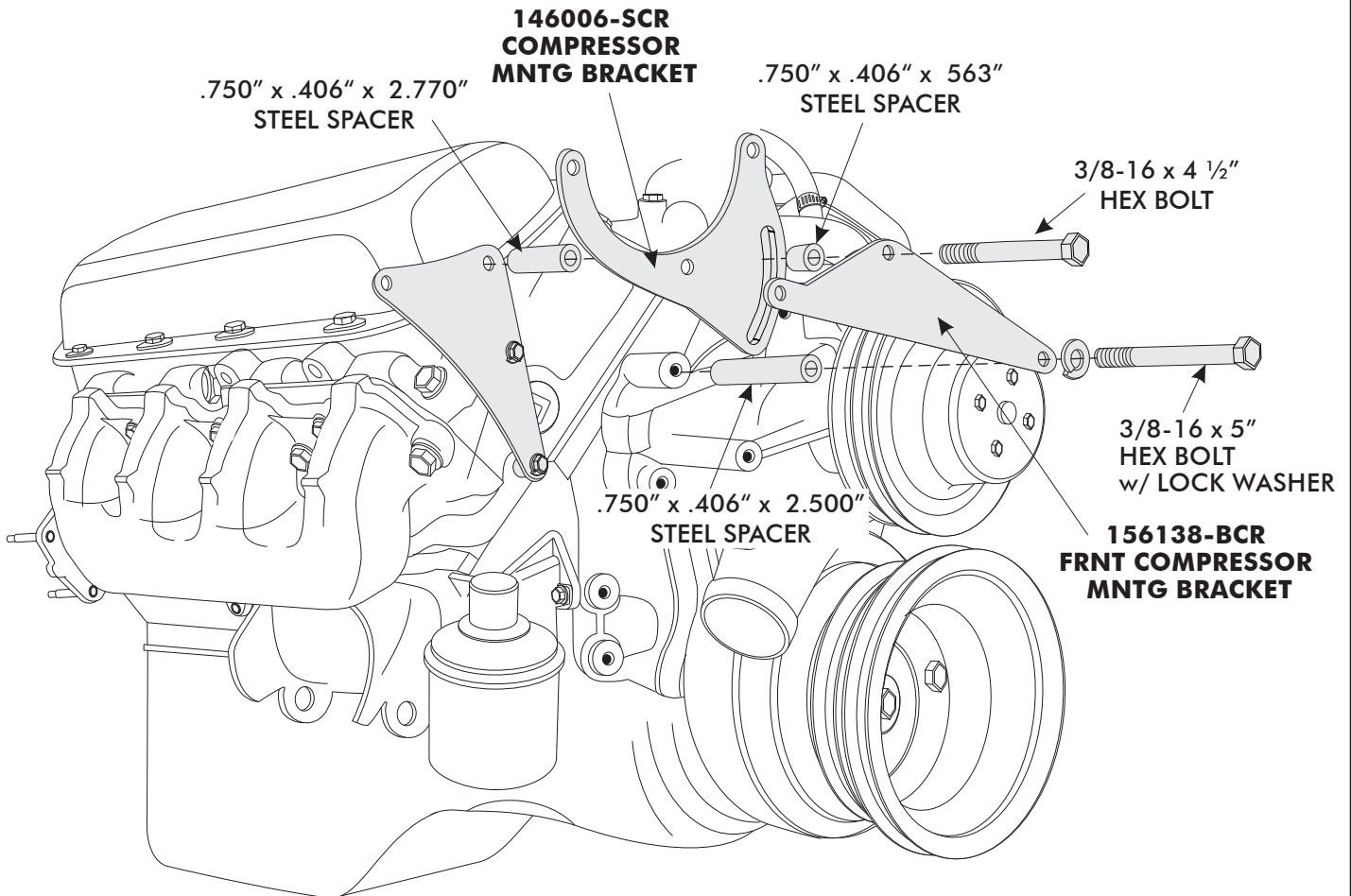

FIGURE 2



BIG BLOCK CHEVY POWER STEERING LONG PUMP PASSENGER SIDE COMPRESSOR BRACKET

COMPRESSOR INSTALLATION

- INSTALL THE COMPRESSOR AS SHOWN IN FIGURE 3 BELOW. SECURE USING A (1) 3/8-16 x 1 1/2" HEX BOLTS WITH LOCKNUTS AND (3) 3/8-16 x 1 1/4" HEX BOLTS WITH LOCKNUTS. SEE FIGURE 3, BELOW.

NOTE: THE COMPRESSOR MOUNTS BETWEEN THE FRONT MOUNTING BRACKET AND THE COMPRESSOR MOUNTING BRACKET. INSTALL THE 3/8-16 x 1 1/2" BOLT THROUGH THE FRONT MOUNTING BRACKET, THEN THROUGH THE COMPRESSOR, AND THEN THROUGH THE COMPRESSOR MOUNTING BRACKET. THE 3/8-16 x 1 1/4" BOLTS WILL GO THROUGH THE COMPRESSOR AND THEN THROUGH THE COMPRESSOR MOUNTING BRACKET.

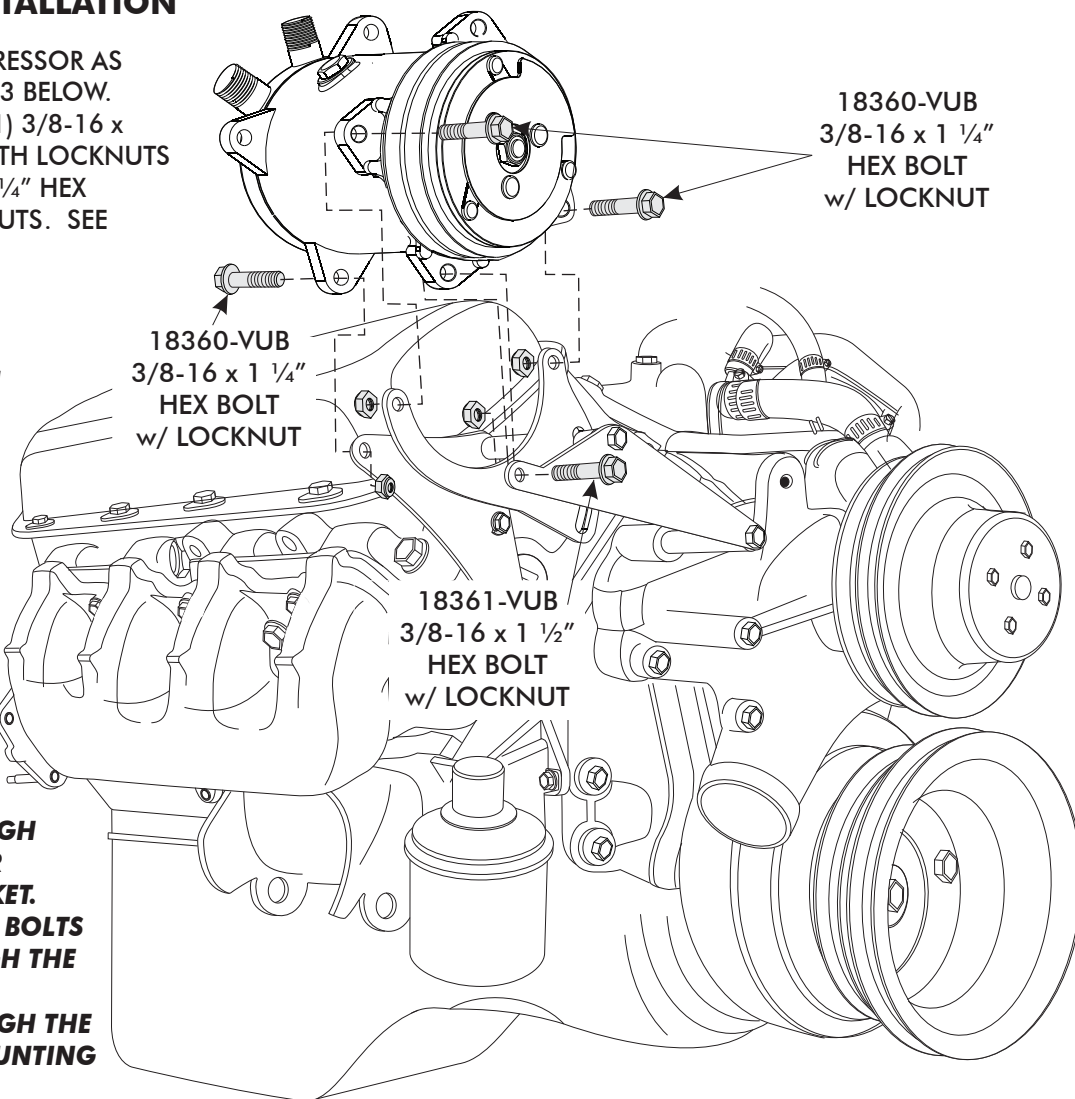
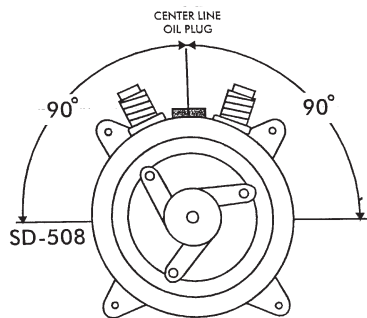

FIGURE 3

MOUNTING & BELT ADJUSTMENT DIAGRAM



COMPRESSORS ARE FACTORY CHARGED w/ OIL

1. WHEN MOUNTING & ADJUSTING YOUR BELT, MAKE SURE THE CENTERLINE OF COMPRESSOR DOES NOT EXCEED 90°. GOING PAST 90° WILL CAUSE LOSS OF OIL CHARGE AND RESULT IN COMPRESSOR FAILURE.
2. DO NOT CONNECT COMPRESSOR CLUTCH WIRE UNTIL SYSTEM IS BEING CHARGED WITH REFRIGERANT. RUNNING COMPRESSOR WITHOUT REFRIGERANT CHARGE WILL RESULT IN COMPRESSOR FAILURE.
3. VINTAGE AIR RECOMMENDS ONLY DAYCO, GATES, OR GOODYEAR BRAND REINFORCED V-BELTS BE USED WITH THIS COMPRESSOR. ANY USE OF LESSER QUALITY BELTS MAY CAUSE COMPRESSOR TO PERFORM IMPROPERLY.

NOTE: FAILURE TO FOLLOW THESE PROCEDURES VOIDS ALL WARRANTIES.

IMPORTANT NOTICE

DO NOT CONNECT COMPRESSOR CLUTCH WIRE UNTIL SYSTEM IS BEING CHARGED w/ REFRIGERANT. RUNNING COMPRESSOR WITHOUT REFRIGERANT WILL VOID WARRANTY!



BIG BLOCK CHEVY POWER STEERING LONG PUMP PASSENGER SIDE COMPRESSOR BRACKET

BELT ROUTING

□ INSTALL BELTS AS SHOWN. SEE FIGURE 4, BELOW.

WE RECOMMEND A BELT LENGTH OF 62". HOWEVER, THIS CAN VARY WITH THE DIAMETER OF YOUR WATER PUMP & CRANKSHAFT PULLEYS.

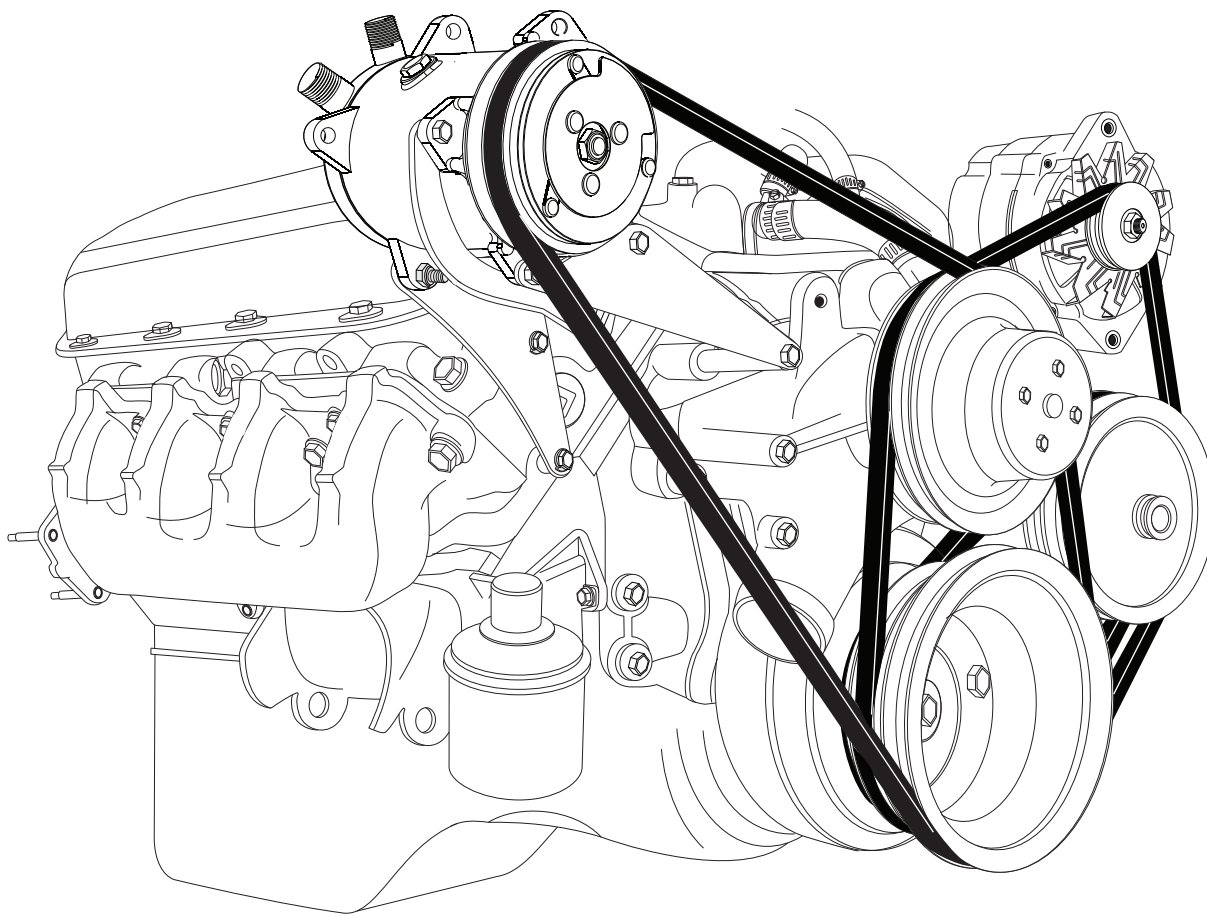
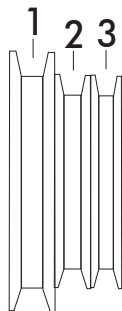

FIGURE 4



CRANK PULLEY GROOVES

- 1. CRANK, FAN & COMPRESSOR
- 2. CRANK, POWER STEERING PUMP, ALT, & FAN
- 3. CRANK, POWER STEERING PUMP



**BIG BLOCK CHEVY POWER STEERING LONG PUMP
PASSENGER SIDE COMPRESSOR BRACKET**

**BIG BLOCK CHEVY POWER STEERING LONG PUMP
PASSENGER SIDE COMPRESSOR BRACKET**

(151371-BCA) PACKING LIST

No.	QTY.	PART No.	DESCRIPTION	CHECK LIST
1.	1	146006-SCR	COMPRESSOR MOUNTING BRKT	_____
2.	1	156137-BCR	BBC LP REAR COMP BRKT	_____
3.	1	156138-BCR	BBC LP FRNT MNTG BRKT	_____
4.	1	191138-HCA	HARDWARE KIT	_____

CHECKED BY: _____
 PACKED BY: _____
 DATE: _____

