



1966-70 Mopar B-Body

Power Steering Bracket Kit
with 383-440 Engine
and TRW/Thompson Power Steering Pump
161010

Please Note:

This Kit Is Designed to Fit 1966-70 Mopar B-Body Vehicles with 383-440 Engines, TRW/Thompson Power Steering Pumps, and Vintage Air Compressor/Alternator Bracket Kit #161002

If Your Vehicle Engine Configuration Does Not Match These Criteria, Modifications May Be Required For Kit to Fit Properly.

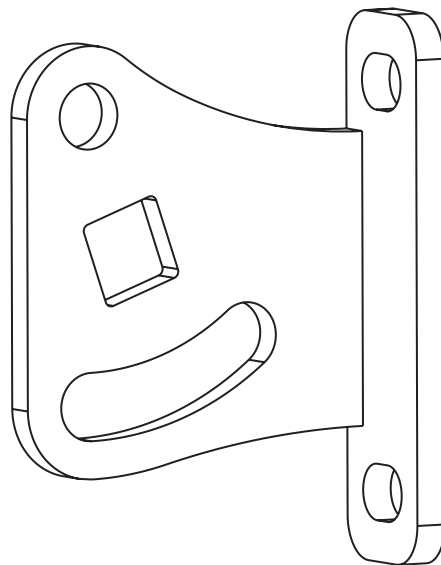

18865 Goll St. San Antonio, TX 78266
Phone: 800-862-6658
Sales: sales@vintageair.com
Tech Support: tech@vintageair.com
www.vintageair.com

Table of Contents

Cover.....	1
Table of Contents.....	2
Packing List/Parts Disclaimer.....	3
Preliminary Steps/Preparation.....	4
Bracket Installation.....	5
Belt Routing, Completed Installation.....	6
Packing List.....	7

Distinguishing a TRW/Thompson from a Federal Power Steering Pump



Rear View of TRW/Thompson Power Steering Pump.

1. The best way to distinguish a TRW/Thompson from a Federal power steering pump is by looking at the back side of the pump. Look for the notch size and the location of the mounting bolt.
2. The TRW/Thompson pump has a hex-shape hole or no hole in the end of the pump shaft.
3. The TRW/Thompson pump uses a reservoir cap that is round and may have vertical serrations, but no ears.



Rear View of Federal Power Steering Pump.

1. The Federal power steering pump has a tapped hole in the end of the pump shaft.
2. The Federal power steering pump uses a cap with ears much like a radiator cap. **NOTE: The Federal cap will fit on a TRW/Thompson pump.**



www.vintageair.com

Packing List: Power Steering Bracket Kit (161010) 1966-70 Mopar B-Body with TRW/Thompson Power Steering Pump

No.	Qty.	Part No.	Description
1.	1	161009	Bracket Assembly, Power Steering

**** Before beginning installation, open all packages and check contents of shipment. Please report any shortages directly to Vintage Air within 15 days. After 15 days, Vintage Air will not be responsible for missing or damaged items.**

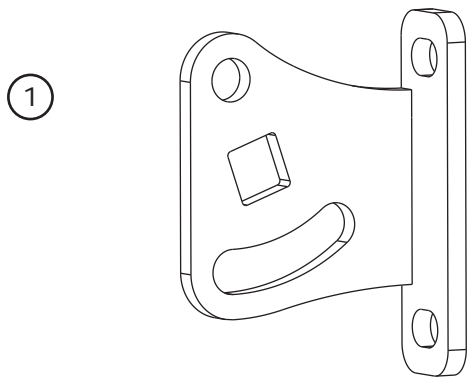

**NOTE: Images may not depict actual parts and quantities.
Refer to packing list for actual parts and quantities.**

NOTE: Before tightening bolts, assemble all brackets loosely to engine. This will ensure proper alignment of all brackets.

Preliminary Steps/Preparation

1. Removing the fan and clutch will give you better access to the belts and power steering pump.
2. Remove water pump and power steering belts.
3. Remove the (2) 3/8" bolts holding the factory power steering bracket top driver side as shown below.
4. With the pump loose, remove the (2) 5/16" bolts holding the front factory power steering bracket to the pump as shown below.
5. You may discard the front factory bracket. It will not be reused.

(2) 3/8" Bolts

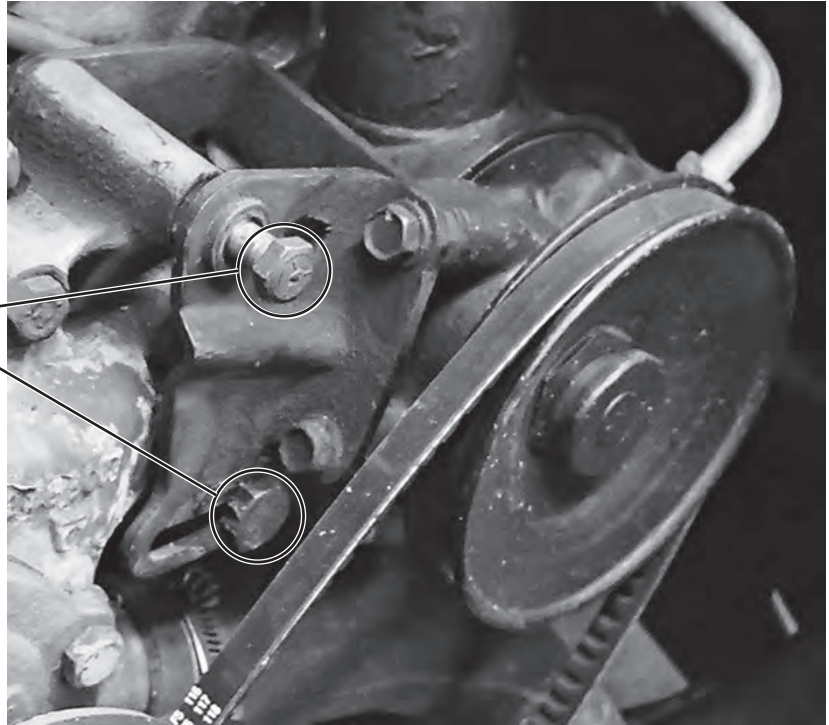

Front Factory
Power Steering Bracket

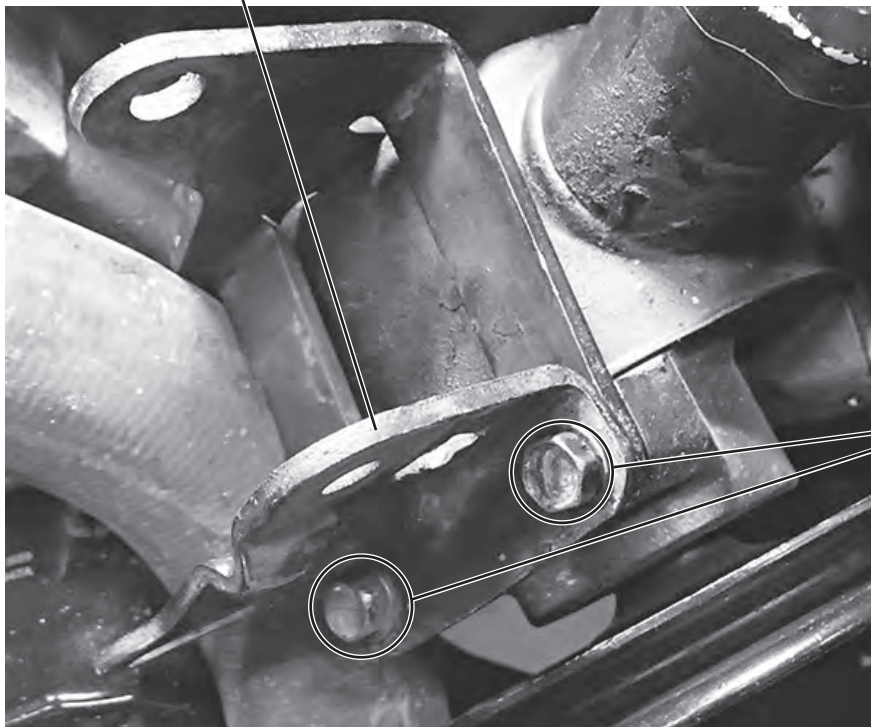

(2) 5/16" Bolts



www.vintageair.com

NOTE: Before tightening bolts, assemble all brackets loosely to engine. This will ensure proper alignment of all brackets.

Bracket Installation

1. Loosely attach bracket part #161009 to the pump with (2) 5/16" bolts you removed earlier in step 4, Page 4 with the slotted groove towards the bottom as shown below.
2. Now reinsert the (2) 3/8" bolts removed in step 3, Page 4 as shown below.
3. Tighten both 5/16" bolts securely.
4. Reinstall and tension power steering pump belt and tighten (2) 3/8" bolts.

Power Steering
Bracket Assembly
161009

(2) 5/16" Bolts

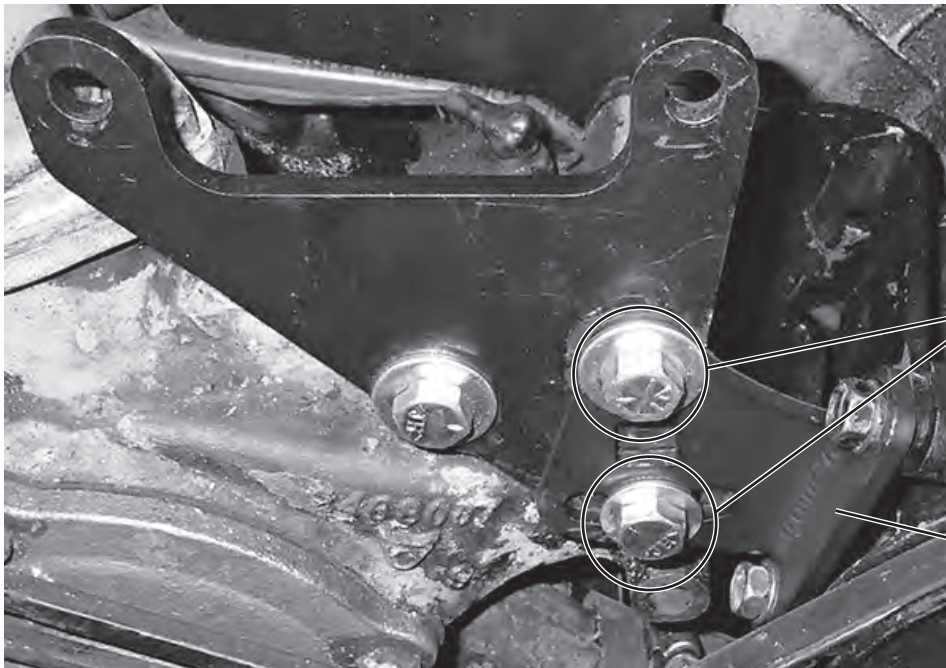
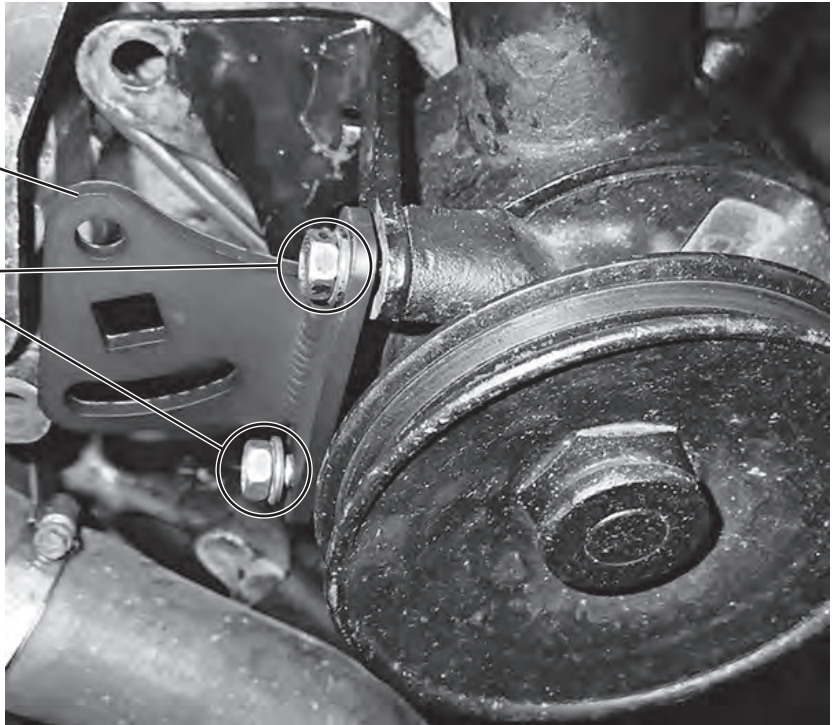

(2) 3/8" Bolts

Power Steering
Bracket Assembly
161009

Belt Routing

1. Route belt as shown below. Vintage Air recommends using only Dayco, Gates or Goodyear brand reinforced V-belts with this power steering bracket kit. Power steering belt length of 39-40" is recommended.

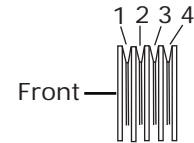

- Crankshaft Pulley Grooves:**
1. Crankshaft and Water Pump
 2. Crankshaft and Power Steering Pump

Completed Installation

1. When complete, your bracket kit installation should appear like the one below.

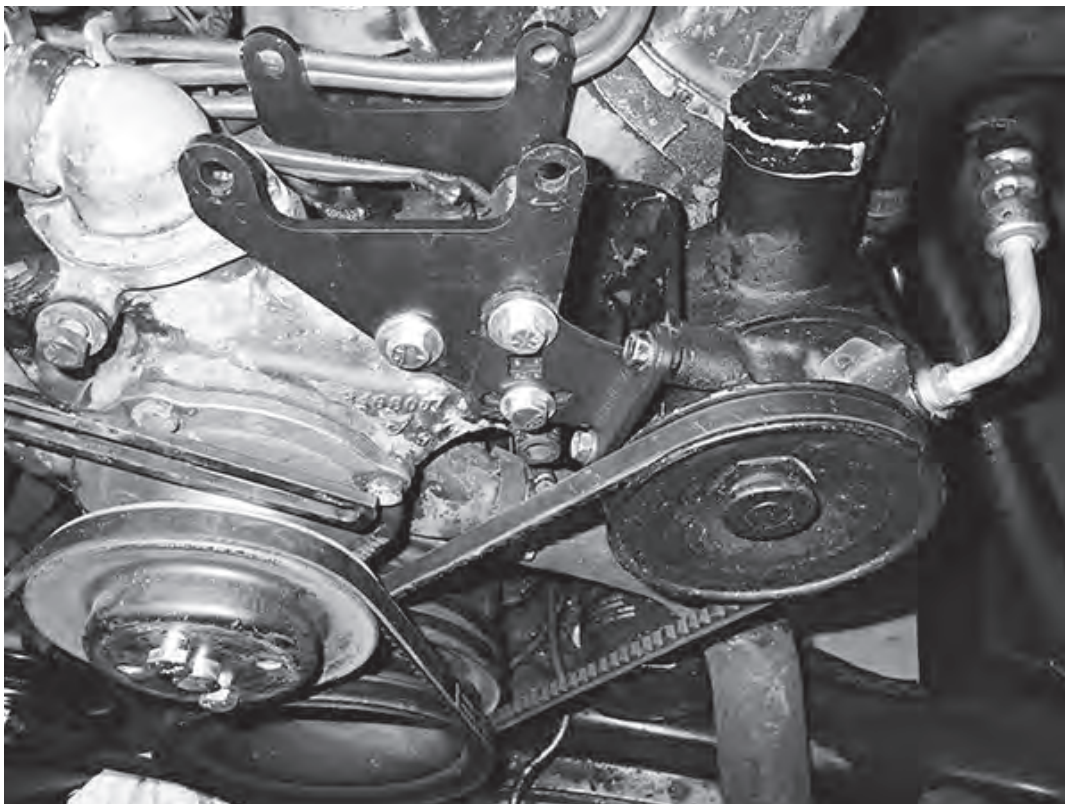



www.vintageair.com

Packing List:
Power Steering Bracket Kit (161010)
1966-70 Mopar B-Body
with TRW/Thompson Power Steering Pump

No.	Qty.	Part No.	Description
1.	1	161009	Bracket Assembly, Power Steering

Checked By: _____

Packed By: _____

Date: _____

①

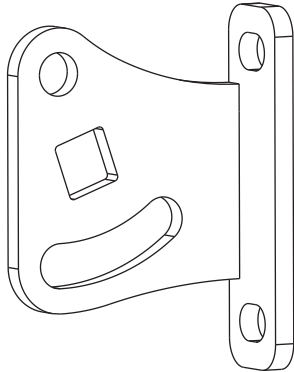

NOTE: Images may not depict actual parts and quantities.
Refer to packing list for actual parts and quantities.