



an ISO 9001:2008 Registered Company

# 1963-67 Chevrolet Corvette

## Auxiliary Electric Condenser Fan Kit

*with Trinary Switch*  
**(30266-CCA)**

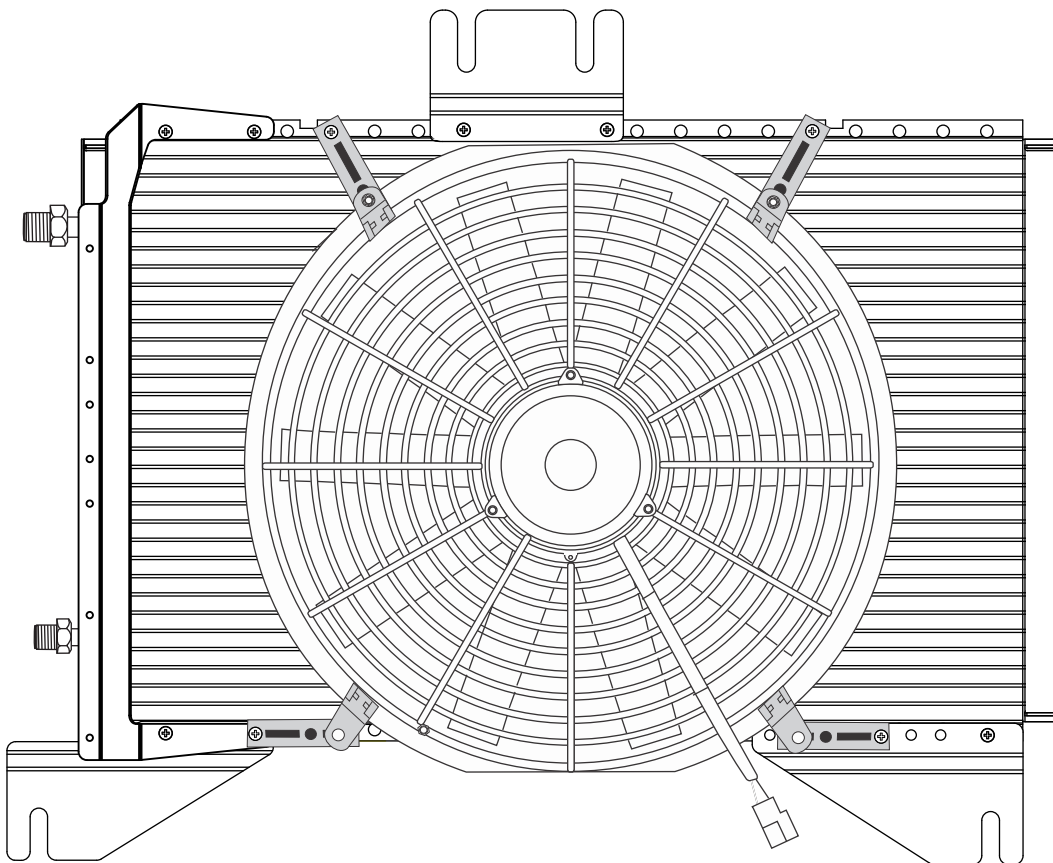

**18865 Goll St. San Antonio, TX 78266**  
**Phone: 800-862-6658**  
**Sales: [sales@vintageair.com](mailto:sales@vintageair.com)**  
**Tech Support: [tech@vintageair.com](mailto:tech@vintageair.com)**  
**[www.vintageair.com](http://www.vintageair.com)**



[www.vintageair.com](http://www.vintageair.com)

# Table of Contents

Cover.....	1
Table of Contents.....	2
Packing List/Parts Disclaimer.....	3
Information Page.....	4
Fan Installation.....	5
Trinary Switch Installation.....	6
Trinary Switch Wiring Diagram, Relay Bracket Installation.....	7
Hood Support Assembly Modification (Optional).....	8
Packing List.....	9



www.vintageair.com

## Packing List: Condenser Fan Kit (30266-CCA)

No.	Qty.	Part No.	Description
1.	1	32140-SHF	Pusher Fan, 14"
2.	4	40139-VUB	Bracket, Fan
3.	4	18249-VUB	Screw, 10-24 x 3/8"
4.	4	18260-VUB	Nut with Star Washer, 10-24
5.	4	18250-VUB	Screw, 10-32 x 1/2"
6.	1	64243-VCB	Bracket, Relay
7.	1	23300-VUW	Wire Harness, Auxiliary Cooling Fan
8.	4	18150-VUB	Nut, 10-32
9.	1	18152-VUB	Nut with Star Washer, 1/4-20
10.	1	110101	Trinary Switch, Male with Connector
11.	1	18605-VUB	Hex Bolt, 5/16-18 x 3/4"
12.	2	18125-VUB	Washer, 3/4"
13.	1	18151-VUB	Locknut, 5/16-18

**\*\* Before beginning installation, open all packages and check contents of shipment. Please report any shortages directly to Vintage Air within 15 days. After 15 days, Vintage Air will not be responsible for missing or damaged items.**

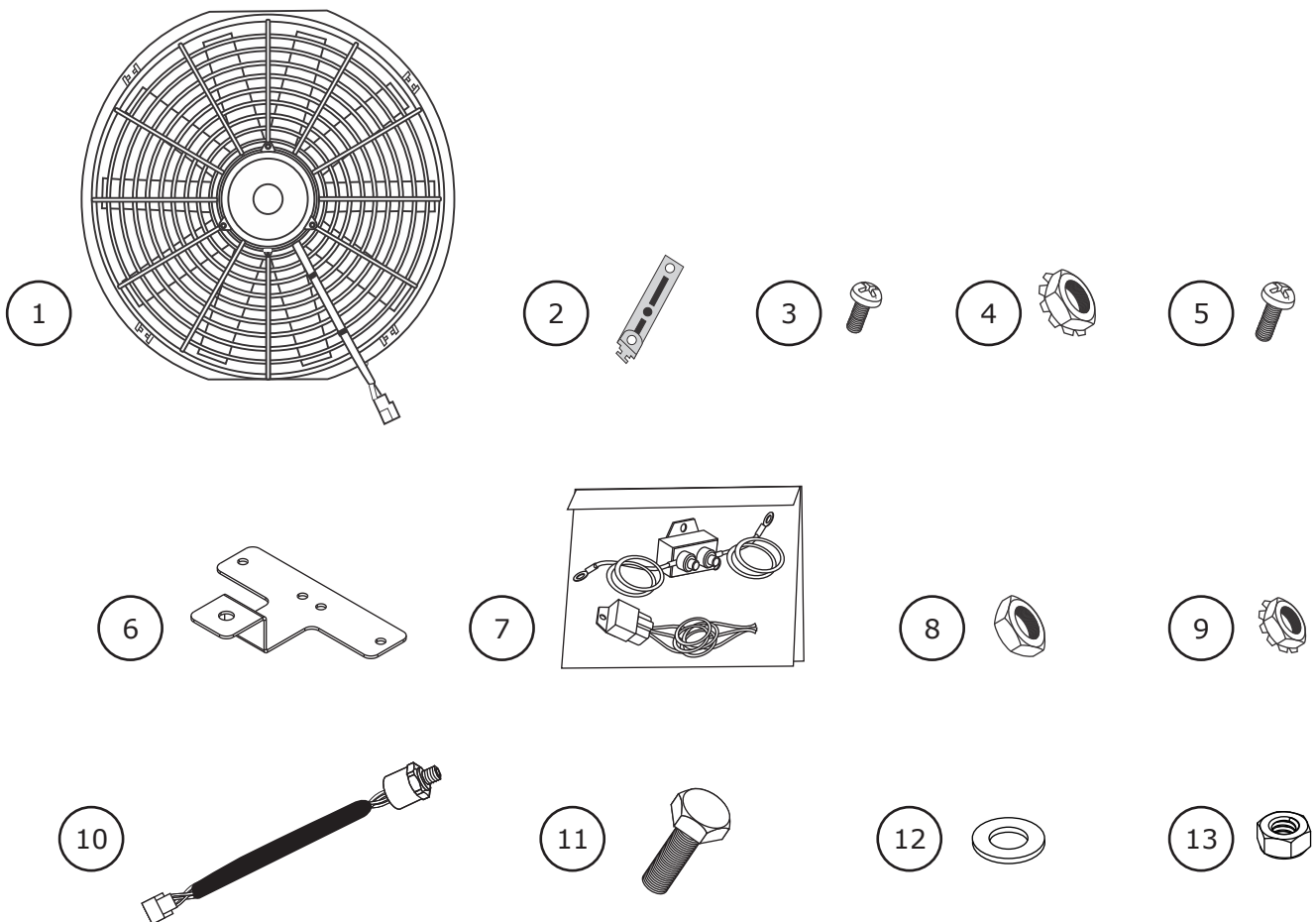

**NOTE: Images may not depict actual parts and quantities. Refer to packing list for actual parts and quantities.**



www.vintageair.com

## Important Notice—Please Read

*For Maximum System Performance, Vintage Air Recommends the Following:*

**NOTE:** Vintage Air systems are designed to operate with R134a refrigerant only. Use of any other refrigerant could damage your A/C system and/or vehicle, and possibly cause a fire, in addition to potentially voiding the warranties of the A/C system and its components.

### Refrigerant Capacities:

**Vintage Air System:** 1.8 lbs. (1 lb., 12 oz.) of R134a, charged by weight with a quality charging station or scale. **NOTE:** Use of the proper type and amount of refrigerant is critical to system operation and performance.

**Other Systems:** Consult manufacturer's guidelines.

### Lubricant Capacities:

**New Vintage Air-supplied Sanden Compressor:** No additional oil needed (Compressor is shipped with proper oil charge).

**All Other Compressors:** Consult manufacturer (Some compressors are shipped dry and will need oil added).

### Safety Switches

Your Vintage Air system is equipped with a binary pressure safety switch. A binary switch disengages the compressor clutch in cases of extreme low pressure conditions (Refrigerant Loss) or excessively high head pressure (406 PSI) to prevent compressor damage or hose rupture. A trinary switch combines Hi/Lo pressure protection with an electric fan operation signal at 254 PSI, and should be substituted for use with electric fans. Compressor safety switches are extremely important since an A/C system relies on refrigerant to circulate lubricant.

### Service Info:

**Protect Your Investment:** Prior to assembly, it is critical that the compressor, evaporator, A/C hoses and fittings, hardlines, condenser and receiver/drier remained capped. Removing caps prior to assembly will allow moisture, insects and debris into the components, possibly leading to reduced performance and/or premature failure of your A/C system. This is especially important with the receiver/drier.

Additionally, when caps are removed for assembly, **BE CAREFUL!** Some components are shipped under pressure with dry nitrogen.

**Evacuate the System for 35-45 Minutes:** Ensure that system components (Drier, compressor, evaporator and condenser) are at a temperature of at least 85° F. On a cool day, the components can be heated with a heat gun **or** by running the engine with the heater on before evacuating. Leak check and charge to specifications.

### Bolts Passing Through Cowl and/or Firewall:

To ensure a watertight seal between the passenger compartment and the vehicle exterior, for all bolts passing through the cowl and/or firewall, Vintage Air recommends coating the threads with silicone prior to installation.

### Heater Hose (Not Included With This Kit):

Heater hose may be purchased from Vintage Air (Part# 31800-VUD) or your local parts retailer. Routing and required length will vary based on installer preference.



www.vintageair.com

## Fan Installation

1. Secure the fan bracket mounting tabs to the fan by sliding the tabs into place on the fan cage (See Figure 1, below).
2. Loosely attach the brackets to the condenser using (4) 10-24 x 3/8" screws and (4) 10-24 nuts with star washers. **NOTE: Be sure to use the correct mounting holes on the condenser (See Figure 2, below).**
3. Center and tighten the fan on the condenser, making sure the top edge of the fan is flush with the bottom edge of the condenser mounting bracket.

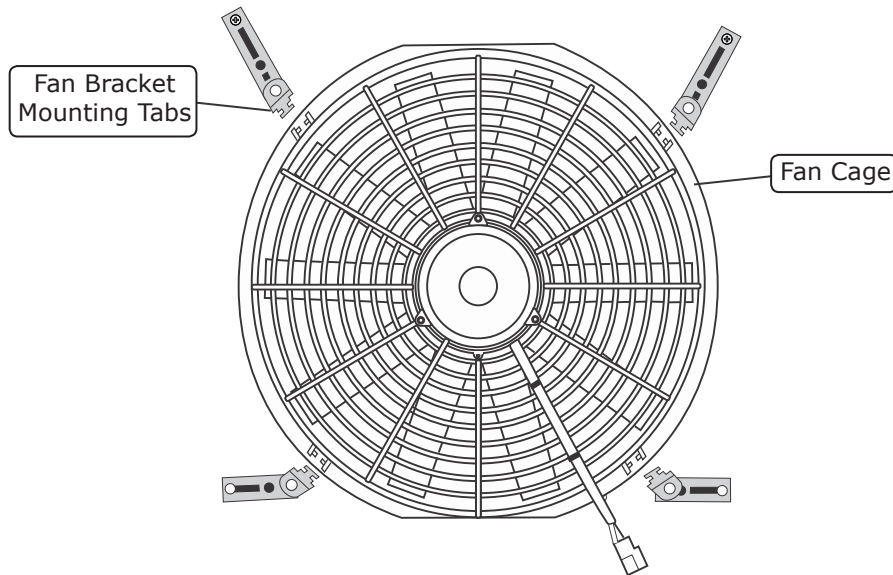

Figure 1

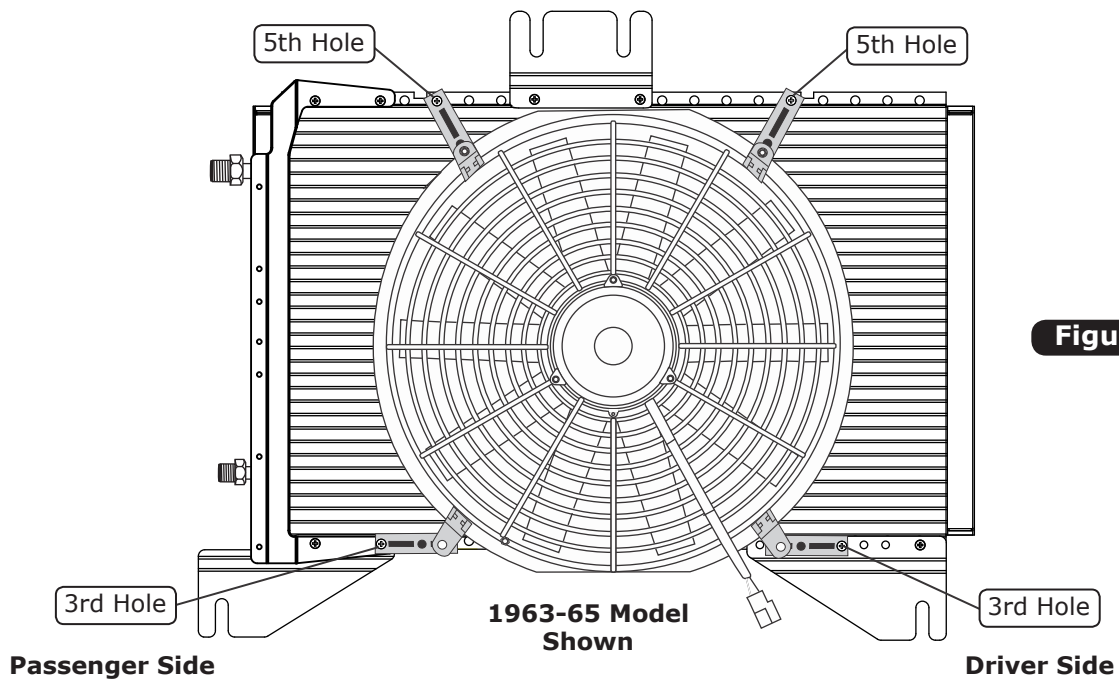

Figure 2

**NOTE: For 1966-67 Models, the bottom brackets will mount to the 4th hole on the passenger side and the 5th hole on the driver side.**



www.vintageair.com

## Trinary Switch Installation

1. Evacuate the A/C system if necessary.
2. Remove the binary switch (discard) (See Figure 3, below).
3. Install the trinary switch.
4. Wire according to the wiring diagram on Page 7.
5. Vintage Air recommends that all A/C systems be serviced by a licensed automotive A/C technician.
6. Evacuate the system for a minimum of 45 minutes prior to charging, and perform a leak check prior to servicing.
7. Charge the system to the capacities stated on Page 4 of this instruction manual.

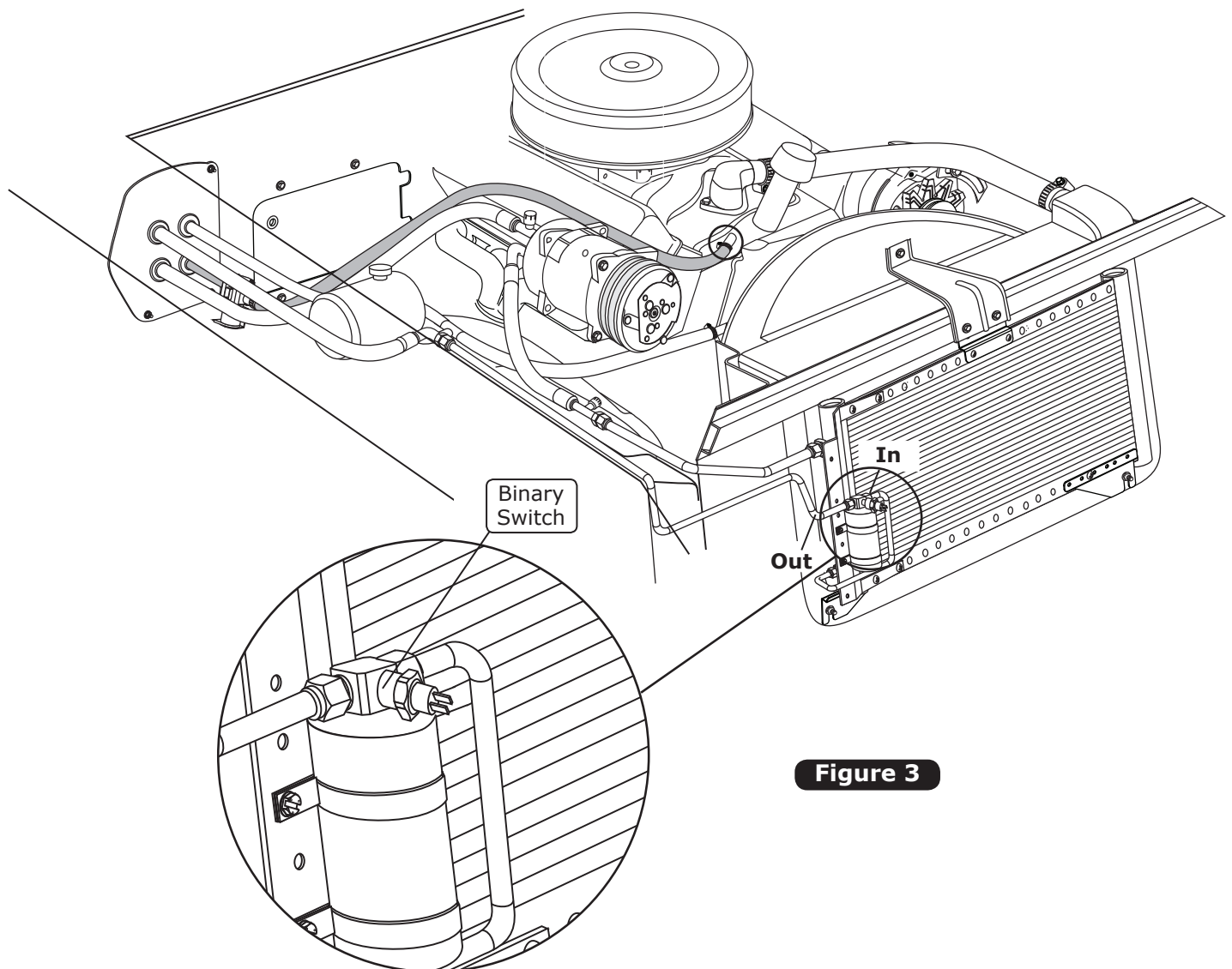



www.vintageair.com

# Trinary Switch Wiring Diagram

**NOTE: Disregard original wiring diagram packaged with evaporator and control panel instructions.**

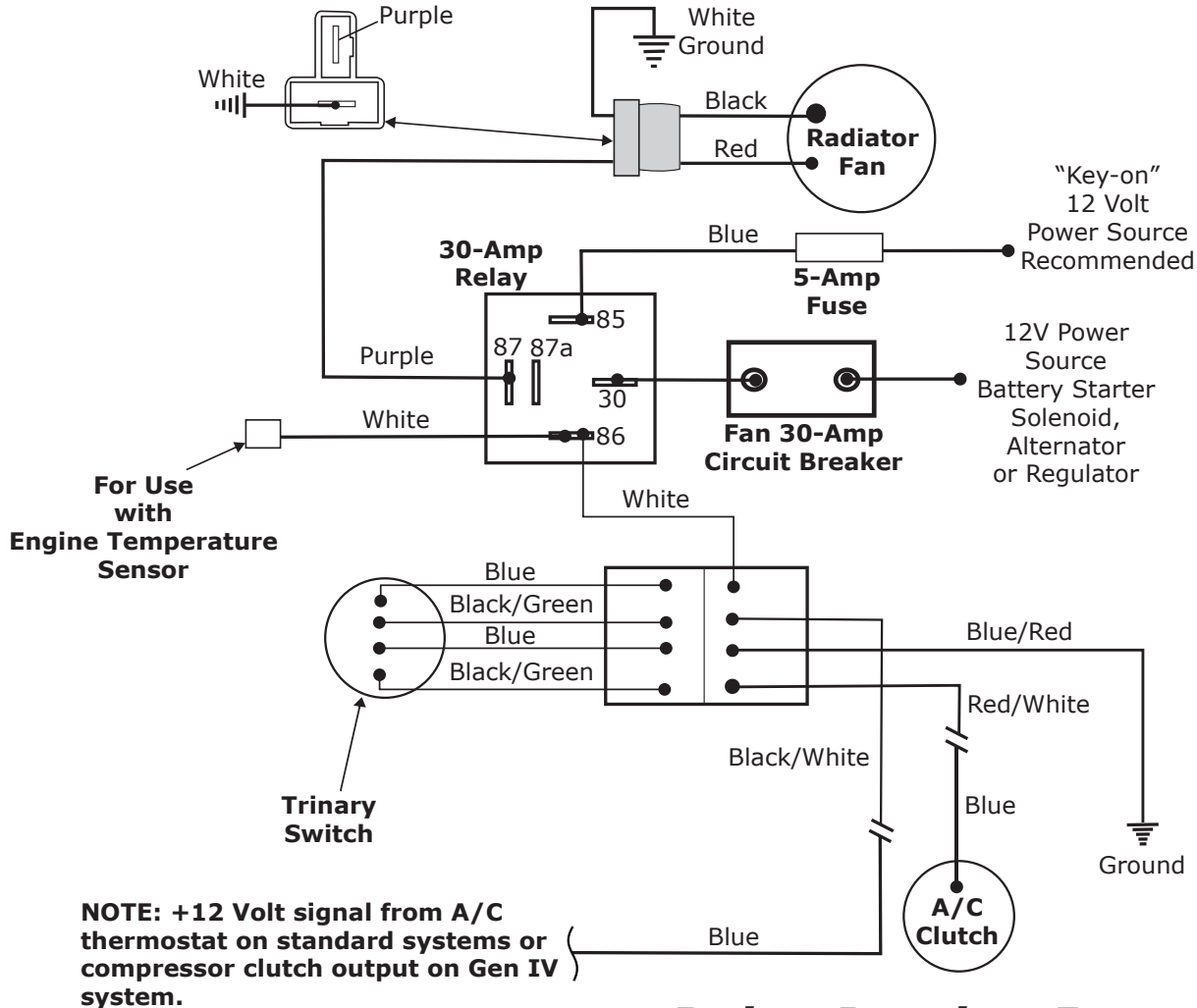

## Relay Bracket Installation

1. Install the circuit breakers and relay onto the relay bracket as shown in Figure 4, below.
2. Install the relay bracket assembly onto the OEM stud on the passenger side firewall, above the stock blower motor hole (See Figure 4a, below).

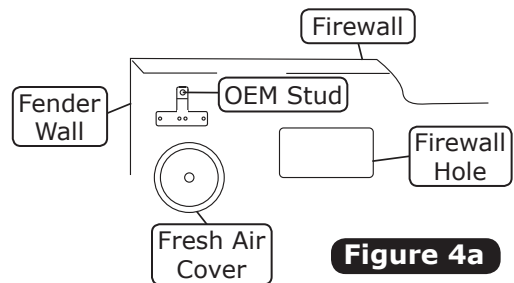
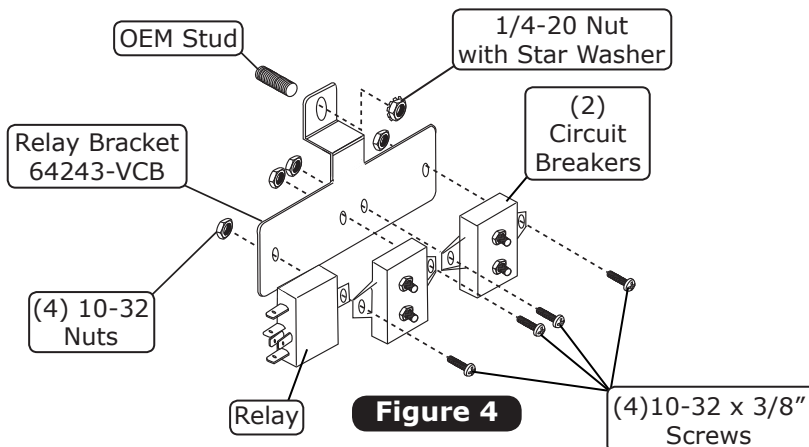



www.vintageair.com

# Hood Support Assembly Modification (Optional)

**NOTE: The following modification is optional for fan clearance.**

1. Remove the OEM rivet connecting the hood support hinge and the hood support assembly (See Figure 5, below).
2. Trim the hood support assembly using the measurements shown in Figure 5, below.
3. Drill a 5/16" hole in the hood support assembly using the measurements shown in Figure 5, below.
4. Relocate the hood support hinge, and assemble as shown in Figure 6, below.

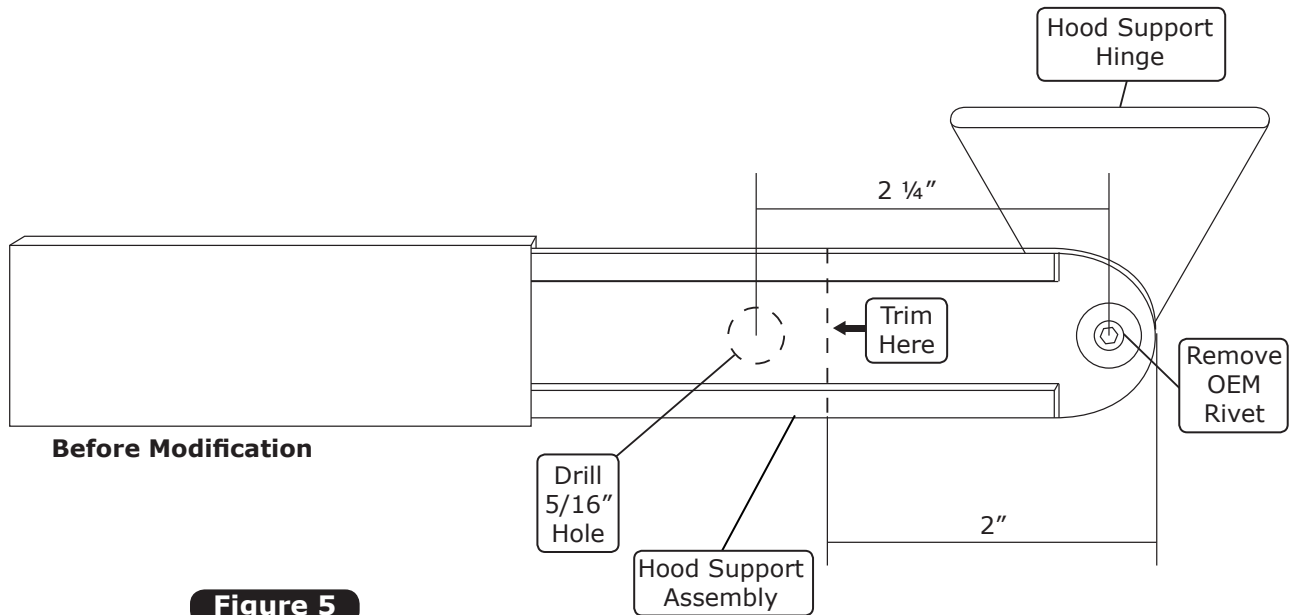

**Figure 5**

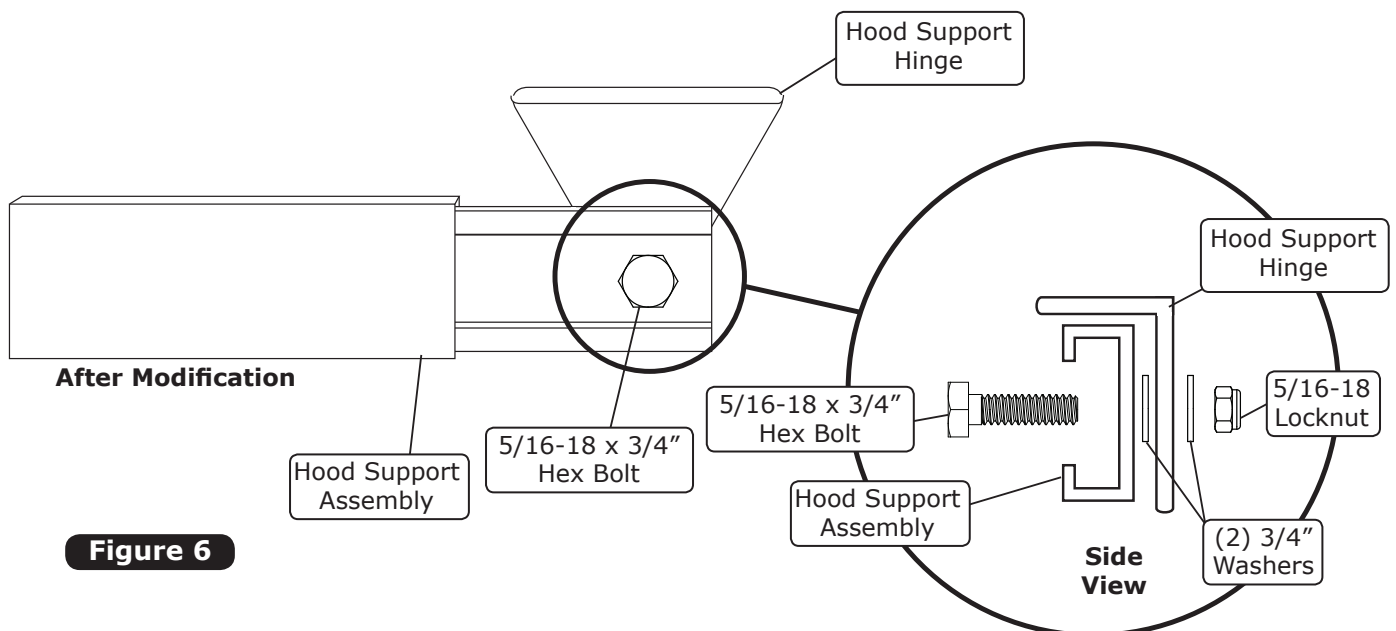

**Figure 6**







www.vintageair.com

## Packing List: Condenser Fan Kit (30266-CCA)

No.	Qty.	Part No.	Description
1.	1	32140-SHF	Pusher Fan, 14"
2.	4	40139-VUB	Bracket, Fan
3.	4	18249-VUB	Screw, 10-24 x 3/8"
4.	4	18260-VUB	Nut with Star Washer, 10-24
5.	4	18250-VUB	Screw, 10-32 x 1/2"
6.	1	64243-VCB	Bracket, Relay
7.	1	23300-VUW	Wire Harness, Auxiliary Cooling Fan
8.	4	18150-VUB	Nut, 10-32
9.	1	18152-VUB	Nut with Star Washer, 1/4-20
10.	1	110101	Trinary Switch, Male with Connector
11.	1	18605-VUB	Hex Bolt, 5/16-18 x 3/4"
12.	2	18125-VUB	Washer, 3/4"
13.	1	18151-VUB	Locknut, 5/16-18

Checked By: \_\_\_\_\_

Packed By: \_\_\_\_\_

Date: \_\_\_\_\_

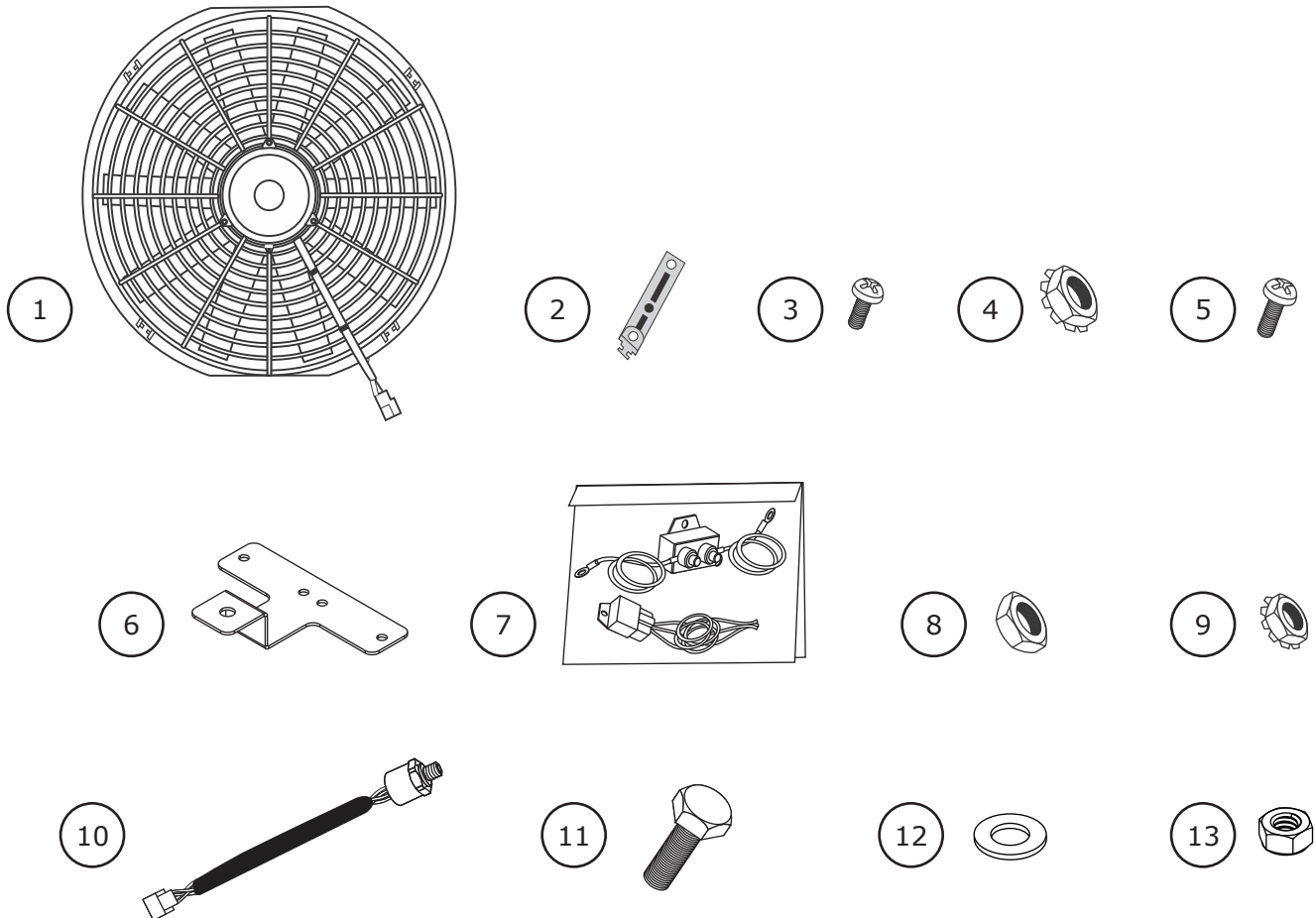

**NOTE: Images may not depict actual parts and quantities.  
Refer to packing list for actual parts and quantities.**