



an ISO 9001:2015 Registered Company

# Streamline

## 3-Knob Vertical Panel, Anodized

### 491226-RVA

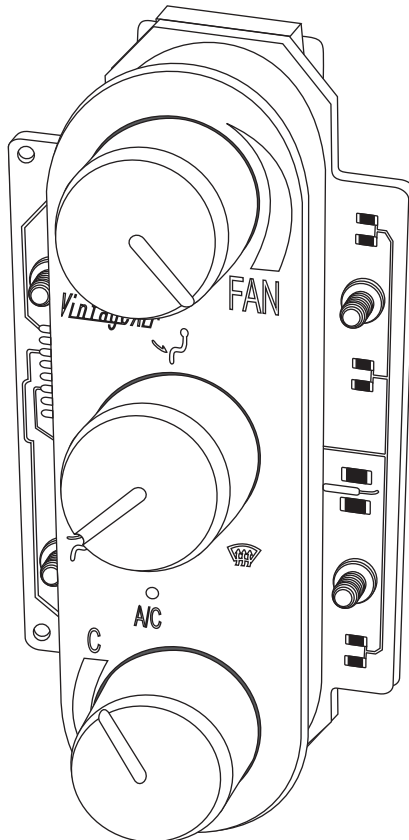

18865 Goll St. San Antonio, TX 78266  
Phone: 800-862-6658  
Sales: [sales@vintageair.com](mailto:sales@vintageair.com)  
Tech Support: [tech@vintageair.com](mailto:tech@vintageair.com)  
[www.vintageair.com](http://www.vintageair.com)



www.vintageair.com

# Table of Contents

Cover.....	1
Table of Contents.....	2
Packing List/Parts Disclaimer.....	3
Control Panel Dimensions and Installation.....	4
Control Panel Installation (Cont.).....	5
Wiring Diagram.....	6
Operation of Controls.....	7
Packing List.....	8

## Important Notice—Please Read

**This control panel is designed to only work with a Gen IV evaporator unit equipped with a 246204-PUA ECU. Please confirm that your unit has the proper ECU prior to installing the control panel as shown below. A replacement ECU can be purchased from Vintage Air if needed.**





www.vintageair.com

# Packing List: Control Panel Kit (491226-RVA) Streamline 3-Knob Vertical, Anodized

No.	Qty.	Part No.	Description
1.	1	491225-RVA	Streamline 3-Knob Vertical Control Panel (Anodized)
2.	1	232007-VUR	Gen IV Universal Control Harness

**\*\* Before beginning installation, open all packages and check contents of shipment. Please report any shortages directly to Vintage Air within 15 days. After 15 days, Vintage Air will not be responsible for missing or damaged items.**

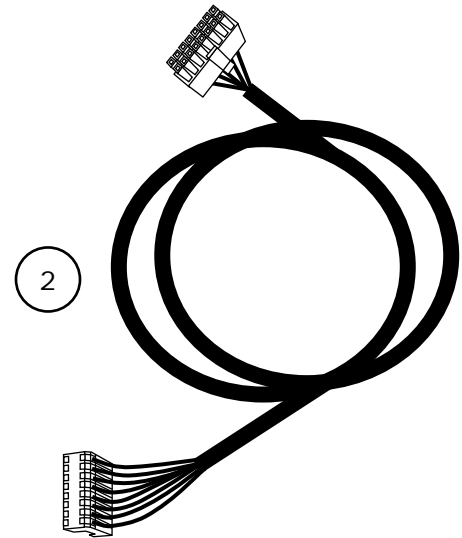
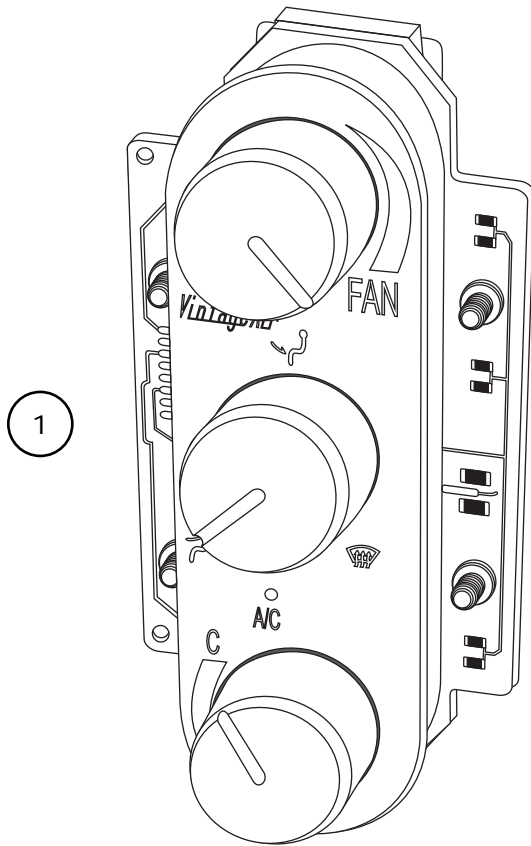

**NOTE: Images may not depict actual parts and quantities. Refer to packing list for actual parts and quantities.**



## Control Panel Dimensions

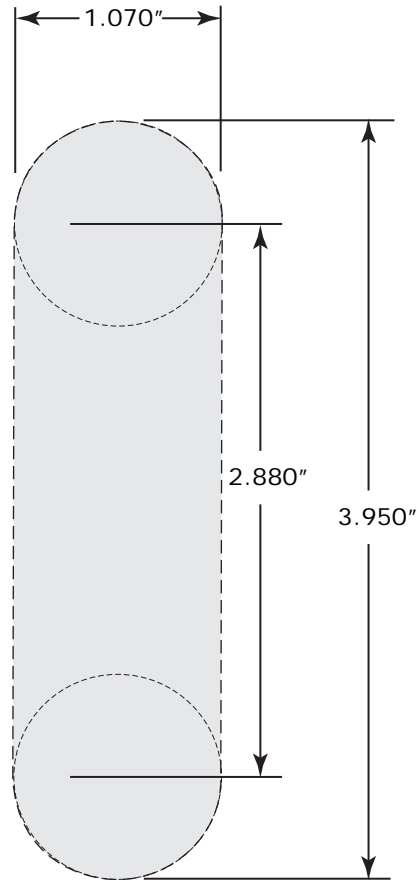

Level This Line

## Control Panel Installation

1. Select a suitable location for the control panel, considering heater control valve location, wiring harness length and operator convenience.
2. After selecting a location for the control panel, mask the area 4 ½" (tall) x 1 ½" (wide).
3. Using the dimensions provided above, mark or scribe the control panel opening location onto the dash. When you are certain that your dimensions and markings are correct, cut the dash to make the control panel opening. **NOTE: Measure twice. Cut once. This opening MUST be a precise fit. Cut the opening undersize, and then file to fit. The mounting screws only hold the panel against the dash. They do not locate the panel laterally. If the opening is oversized, the panel may shift during use.**
4. Install the control panel face through the opening in the dash. Place the control panel PC board assembly behind the dash, and secure it to the control panel face using the (4) 8-32 x 3/8" screws (See Figure 1 and 2a, Page 5). **NOTE: When tightening the control panel mounting screws, hand tighten until the screw contacts the back side of the dash. Then, using a screwdriver, tighten an additional 1/2 turn. Do not over tighten, as this may cause damage to the PC board or the dash.**
5. Plug the control panel wiring harness into the control panel and the ECU on the evaporator (See Figure 2, Page 5).
6. Wire according to the wiring diagram on Page 6.



# Control Panel Installation (Cont.)

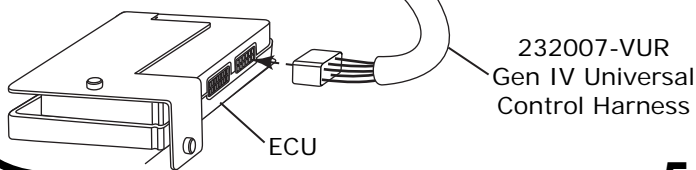
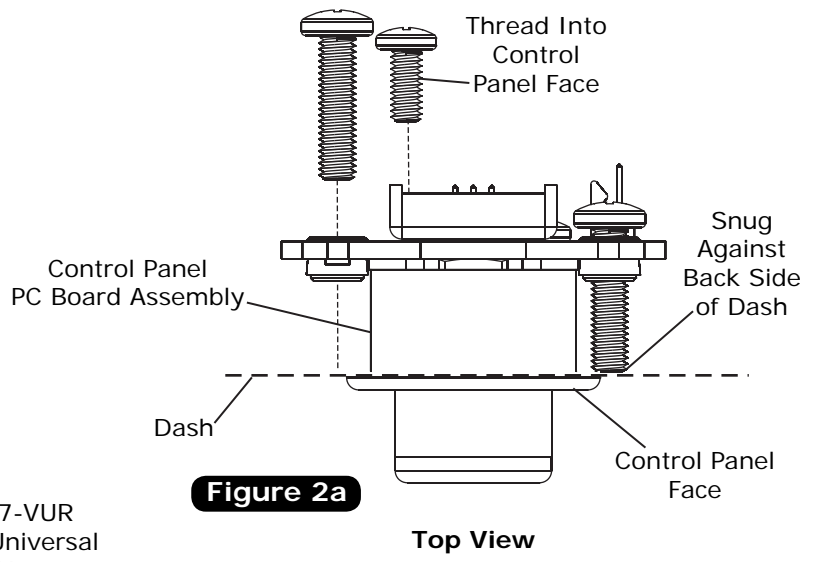
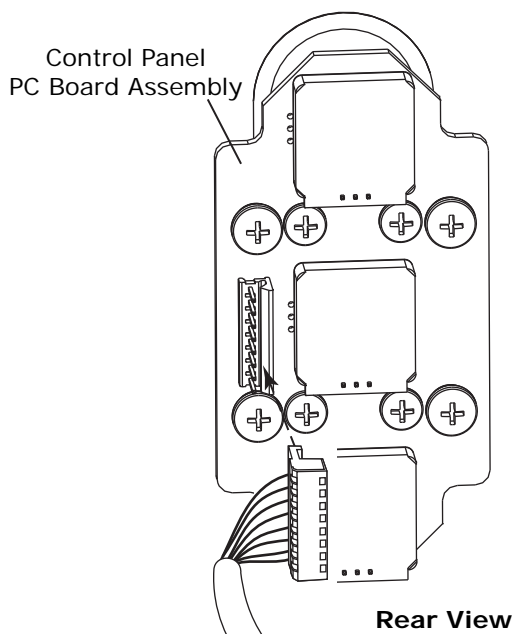
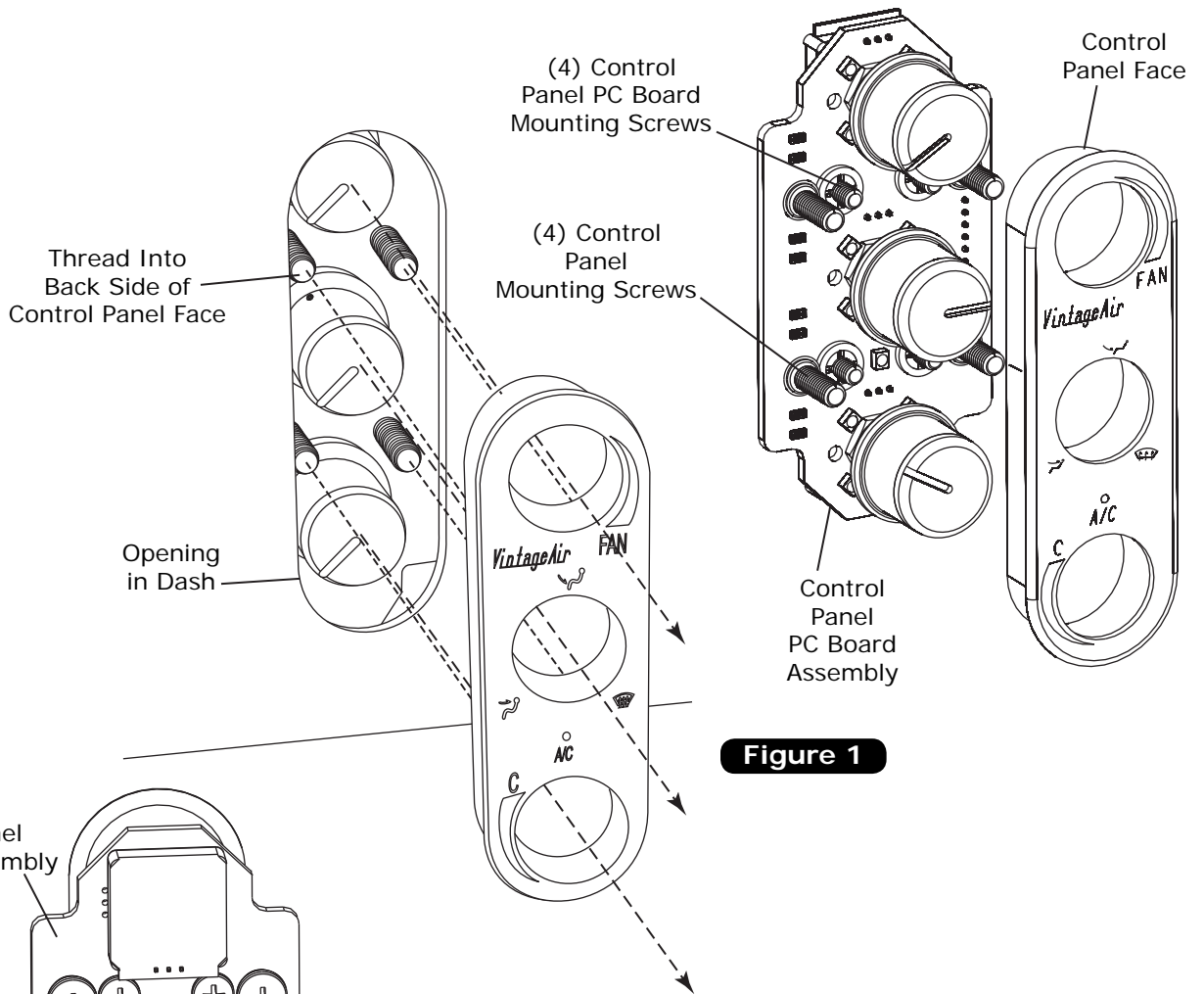



www.vintageair.com

# Wiring Diagram

## 232007-VUR

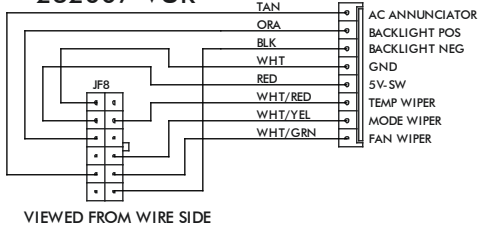

## 232002-VUA

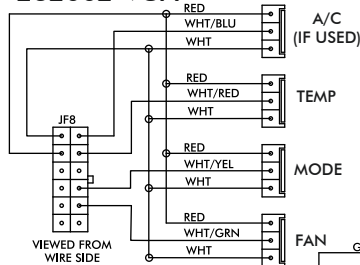

## GEN IV ECU

GEN IV WIRING DIAGRAM  
REV E, 10/6/2017

## PRE-WIRED

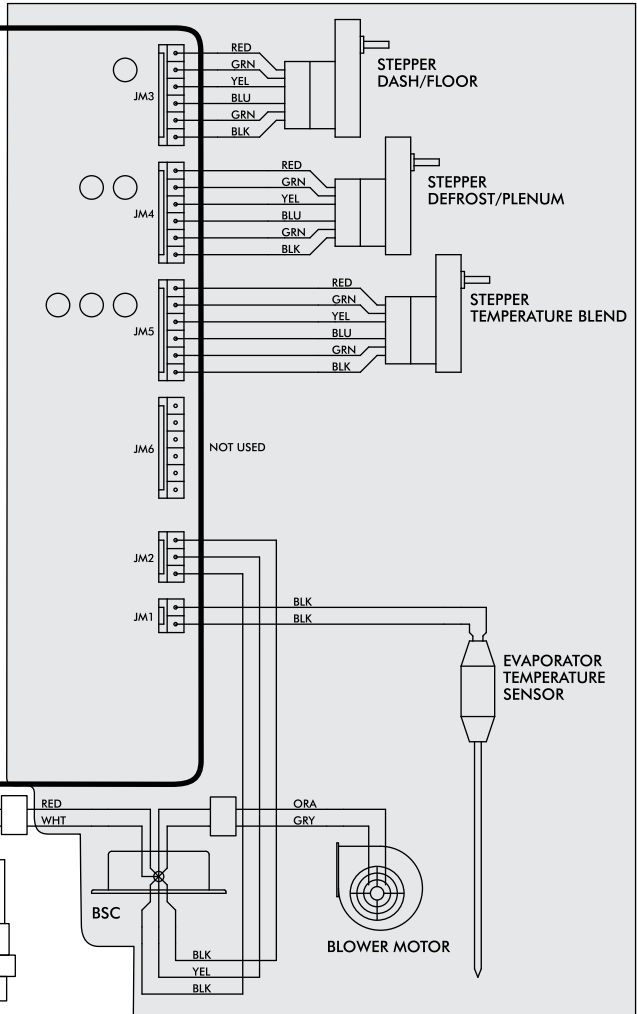

## PROGRAM

N/A  
\* DASH LAMP (IF USED)  
\*\*\* WIDE OPEN THROTTLE SWITCH (OPTIONAL)

IGNITION SWITCH + 12v

\*\* CIRCUIT BREAKER 30 AMP

COMPRESSOR RELAY

BINARY OR TRINARY SAFETY SWITCH

CMPR

HEATER CONTROL VALVE

NOTE: = CHASSIS GROUND

\* Dash Lamp Is Used Only With Type 232007-VUR Harness.

\*\* Warning: Always Mount Circuit Breaker As Close to the Battery As Possible. (NOTE: Wire Between Battery and Circuit Breaker Is Unprotected and Should Be Carefully Routed to Avoid a Short Circuit).

\*\*\* Wide Open Throttle Switch Contacts Close Only at Full Throttle, Which Disables A/C Compressor.



www.vintageair.com

## Operation of Controls

On Gen IV systems with three lever/knob controls, the temperature control toggles between heat and A/C operations. To activate A/C, move the temperature lever/knob all the way to cold and then back it off to the desired vent temperature. For heat operation, move the temperature lever/knob all the way to hot and then adjust to the desired vent temperature. The blower will momentarily change speed, each time you toggle between operations, to indicate the change. **NOTE: For proper control panel function, refer to control panel instructions for calibration procedure.**

### Blower Speed

This lever/knob controls blower speed, from OFF to HI.

### Mode Control

This lever/knob controls the mode positions, from DASH to FLOOR to DEFROST, with a blend in between.

### Temperature Control

This lever/knob controls the temperature, from HOT to COLD.

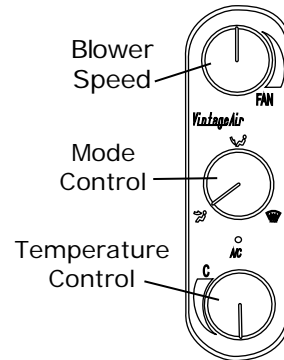

## A/C Operation

### Blower Speed

Adjust to desired speed.

### Mode Control

Adjust to desired mode position (DASH position recommended).

### Temperature Control

For A/C operation, adjust to coldest position to engage compressor (Adjust between HOT and COLD to reach desired temperature).

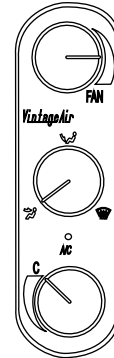

## Heat Operation

### Blower Speed

Adjust to desired speed.

### Mode Control

Adjust to desired mode position (FLOOR position recommended).

### Temperature Control

For maximum heating, adjust to hottest position (Adjust between HOT and COLD to reach desired temperature).

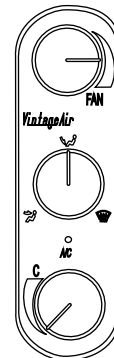

## Defrost/De-fog Operation

### Blower Speed

Adjust to desired speed.

### Temperature Control

Adjust to desired temperature.

### Mode Control

Adjust to DEFROST position for maximum defrost, or between FLOOR and DEFROST positions for a bi-level blend (Compressor is automatically engaged).





www.vintageair.com

# Packing List: Control Panel Kit (491226-RVA) Streamline 3-Knob Vertical, Anodized

No.	Qty.	Part No.	Description
1.	1	491225-RVA	Streamline 3-Knob Vertical Control Panel (Anodized)
2.	1	232007-VUR	Gen IV Universal Control Harness

Checked By: \_\_\_\_\_  
Packed By: \_\_\_\_\_  
Date: \_\_\_\_\_

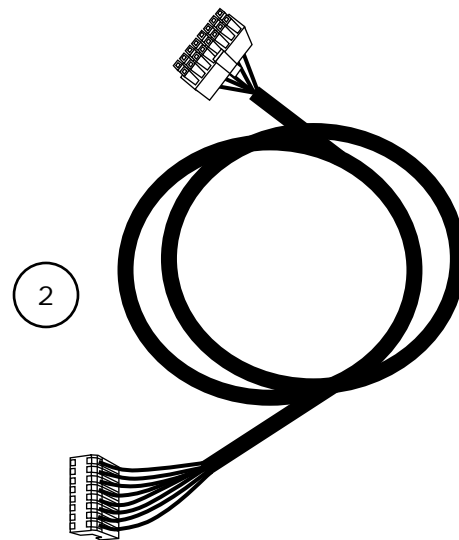
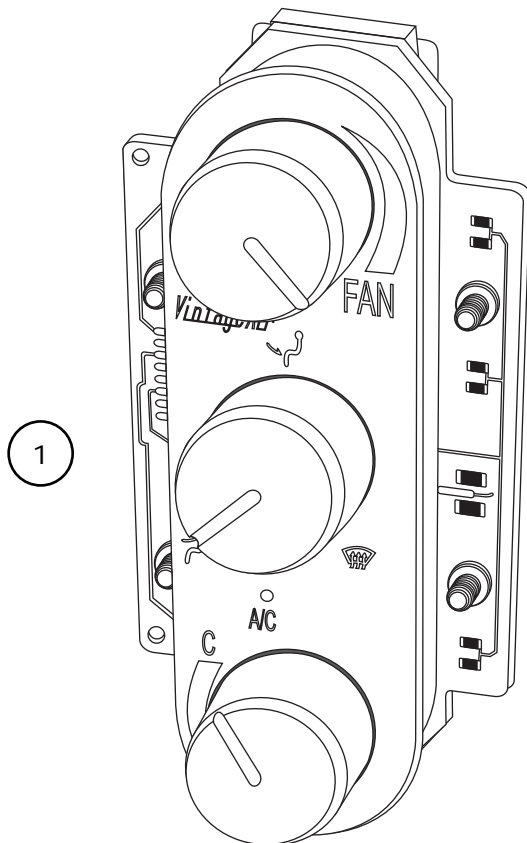

**NOTE: Images may not depict actual parts and quantities.  
Refer to packing list for actual parts and quantities.**