



1982-88 Monte Carlo/ El Camino

with Factory Air
Gen 5 Evaporator Kit
Magnum (564332)
Super Magnum (564333)



18865 Goll St. San Antonio, TX 78266
Phone: 800-862-6658
Sales: sales@vintageair.com
Tech Support: tech@vintageair.com
www.vintageair.com



www.vintageair.com

Table of Contents

Cover.....	1
Table of Contents.....	2
Packing List/Parts Disclaimer.....	3
Information Page.....	4
Wiring Notice.....	5
Engine Compartment Disassembly.....	6-7
Condenser Assembly and Installation, Compressor Brackets, Passenger Compartment Disassembly	8-9
Firewall Modification and Insulation.....	10-11
Dash Louver Adapter Preparation.....	12
Evaporator Preparation.....	13-14
Evaporator Installation.....	15-16
Wiring Installation.....	17-18
Duct Hose Routing.....	19
Dash, Defrost Duct and Center Hose Adapter Installation, Passenger Compartment Wiring.....	20-21
Control Panel Installation, Inner Fender Reinstallation, Lubricating O-rings.....	22
Firewall Cover Boot Plate Installation.....	23
A/C Hose Installation, Heater Hose & Heater Control Valve Installation.....	24-26
Engine Compartment Wiring.....	27-28
Water Deflector Installation.....	29
Drain Hose Installation, Courtesy Lamp Relocation (If Equipped).....	30
OEM ECU Relocation (Super Magnum Only).....	31
Final Steps: Installation Check.....	32
Glove Box Modification and Installation (Style 1), Glove Box Modification and Installation (Style 2).	33
Final Steps: Completing the Install.....	34
Quality Crimp Guideline.....	35
Gen 5 Wiring Diagram.....	36
Gen 5 Wiring Connection Instruction.....	37
Operation of Controls.....	38
Troubleshooting Guide.....	39
Troubleshooting Guide (Cont.), Advanced Diagnostics and Troubleshooting Guide.....	40
Packing List.....	41

IMPORTANT INFORMATION

- When installing the Gen 5 Super Magnum kit, the OEM ECU will have to be relocated from its factory location. When designing this kit, the OEM ECU was relocated under the evaporator module on the passenger side, under the carpet (See Page 31). Modification of the OEM dash mounting bracket and firewall will be necessary for the installation of the super Magnum module, due to the larger blower motor.

A detailed tech video outlining the installation process of a Gen IV unit is available on Vintage Air's YouTube channel at <https://bit.ly/3KNMESH>.

Installation processes of Gen IV and Gen 5 units are similar. Viewing the tech video along with the written instructions will provide the installer the most detailed installation procedure.



www.vintageair.com

Packing List: Evaporator Kit (564332)

No.	Qty.	Part No.	Description
1.	1	765100	Gen 5 Magnum Module
2.	1	784332	Accessory Kit

** Before beginning installation, open all packages and check contents of shipment. Please report any shortages directly to Vintage Air within 15 days. After 15 days, Vintage Air will not be responsible for missing or damaged items.



Gen 5 Magnum
Module
765100

Packing List: Evaporator Kit (564333)

No.	Qty.	Part No.	Description
1.	1	765200	Gen 5 Super Magnum Module
2.	1	784332	Accessory Kit

** Before beginning installation, open all packages and check contents of shipment. Please report any shortages directly to Vintage Air within 15 days. After 15 days, Vintage Air will not be responsible for missing or damaged items.



Gen 5 Super Magnum
Module
765200

2

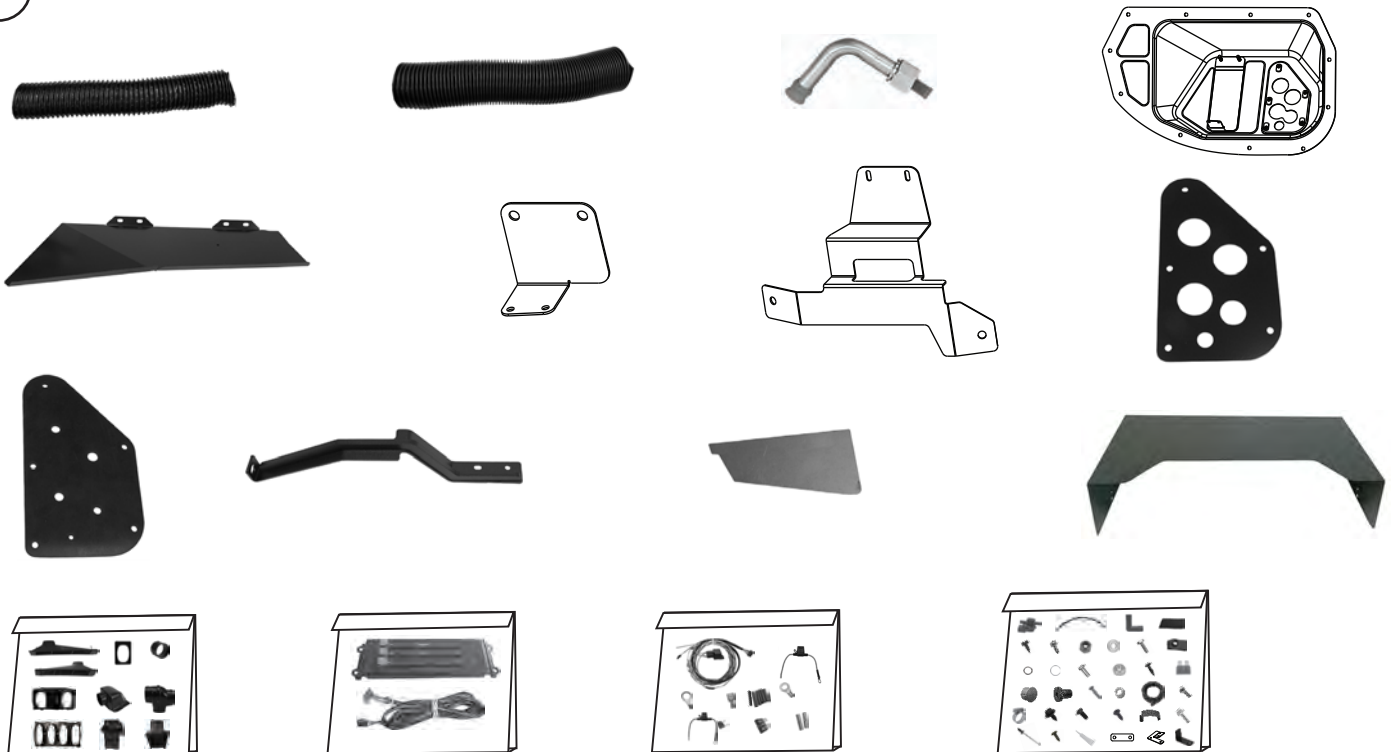

Accessory Kit
784332

NOTE: Images may not depict actual parts and quantities.
Refer to packing list for actual parts and quantities.



www.vintageair.com

Important Notice—Please Read

For Maximum System Performance, Vintage Air Recommends the Following:

NOTE: Vintage Air systems are designed to operate with R134a refrigerant only. Use of any other refrigerant could damage your A/C system and/or vehicle, and possibly cause a fire, in addition to potentially voiding the warranties of the A/C system and its components.

Refrigerant Capacities:

Vintage Air System: 1.8 lbs. (28.8 oz.) or 816 grams of **R134a**, charged by weight with a quality charging station or scale. **NOTE: Use of the proper type and amount of refrigerant is critical to system operation and performance.**

Other Systems: Consult manufacturer's guidelines.

Lubricant Capacities:

New Vintage Air-Supplied Sanden Compressor: No additional oil needed (Compressor is shipped with proper oil charge).

All Other Compressors: Consult manufacturer (Some compressors are shipped dry and will need oil added).

Safety Switches

Your Vintage Air system is equipped with a binary pressure safety switch. A binary switch disengages the compressor clutch in cases of extreme low pressure conditions (refrigerant loss) or excessively high head pressure (406 PSI) to prevent compressor damage or hose rupture. A trinary switch combines Hi/Lo pressure protection with an electric fan operation signal at 254 PSI, and should be substituted for use with electric fans. Compressor safety switches are extremely important since an A/C system relies on refrigerant to circulate lubricant.

Service Info:

Protect Your Investment: Prior to assembly, it is critical that the compressor, evaporator, A/C hoses and fittings, hardlines, condenser and receiver/drier remain capped. Removing caps prior to assembly will allow moisture, insects and debris into the components, possibly leading to reduced performance and/or premature failure of your A/C system. This is especially important with the receiver/drier.

Additionally, when caps are removed for assembly, **BE CAREFUL!** Some components are shipped under pressure with dry nitrogen.

Evacuate the System for 35-45 Minutes: Ensure that system components (Drier, compressor, evaporator and condenser) are at a temperature of at least 85°F. On a cool day, the components can be heated with a heat gun **or** by running the engine with the heater on before evacuating. Leak check and charge to specifications.

Bolts Passing Through Cowl and/or Firewall:

To ensure a watertight seal between the passenger compartment and the vehicle exterior, for all bolts passing through the cowl and/or firewall, Vintage Air recommends coating the threads with silicone prior to installation.

Heater Hose (not included with this kit):

Heater hose may be purchased from Vintage Air (Part#31800-VUD) or your local parts retailer. Routing and required length will vary based on installer preference.



www.vintageair.com

Important Wiring Notice—Please Read

Some vehicles may have had some or all of their radio interference capacitors removed. There should be a capacitor found at each of the following locations:

- 1. On the positive terminal of the ignition coil.**
- 2. If there is a generator, on the armature terminal of the generator.**
- 3. If there is a generator, on the battery terminal of the voltage regulator.**

Most alternators have a capacitor installed internally to eliminate what is called “whining” as the engine is revved. If whining is heard in the radio, or just to be extra cautious, a radio interference capacitor can be added to the battery terminal of the alternator.

It is also important that the battery lead is in good shape and that the ground leads are not compromised. There should be a heavy ground from the battery to the engine block, and additional grounds to the body and chassis.

If these precautions are not observed, it is possible for voltage spikes to be present on the battery leads. These spikes come from ignition systems and charging systems, and from switching some of the vehicle’s other systems on and off. Modern computer-operated equipment can be sensitive to voltage spikes on the power leads, which can cause unexpected resets, strange behavior and/or permanent damage.

Vintage Air strives to harden our products against these types of electrical noise, but there is a point where a vehicle’s electrical system can be degraded so much that nothing can help.

Radio interference capacitors should be available at most auto and truck parts suppliers. They typically are cylindrical in shape, a little over an inch long and a little over a half-inch in diameter, and they have a single lead coming from one end of the cylinder with a terminal on the end of the wire, as well as a mounting clip which is screwed into a good ground on the vehicle. The specific value of the capacitance is not too significant in comparison to ignition capacitors that are matched with the coil to reduce pitting of the points.

- Care must be taken, when installing the compressor lead, not to short it to ground. The compressor lead must not be connected to a condenser fan or to any other auxiliary device. Shorting to ground or connecting to a condenser fan or any other auxiliary device may damage wiring or the compressor relay, and/or cause a malfunction.
- When installing ground leads on Gen 5 systems, the blower control ground and ECU ground must be connected directly to the negative battery post.
- For proper system operation, the heater control valve must be connected to the ECU.



www.vintageair.com

Engine Compartment Disassembly

NOTE: Before starting the installation, check the function of the vehicle (horn, lights, etc.) for proper operation, and study the instructions, illustrations, photos & diagrams.

Perform the Following:

1. Disconnect the battery (See Photo 1, below).
2. Evacuate the A/C system (if necessary).
3. Jack up the front of the vehicle and support it with jack stands.
4. Remove the passenger-side wheel.
5. Drain the radiator (See Photo 1, below).
6. Remove the air cleaner and intake duct hose (See Photo 1, below).
7. Remove the radiator cooling fan (See Photo 2, Page 7).
8. Remove the fan shroud (See Photo 1, below).
9. Remove the OEM heater hoses (See Photo 1, below).
10. Remove the OEM coolant reservoir and any other components attached to the inner fender (See Photo 1, below).
11. Remove the windshield wiper arms and wiper park ramps (See Photo 1, below).
12. Remove the lower windshield trim and brackets (See Photo 1, below).
13. Remove the cowl weather stripping (See Photo 1, below).
14. Remove the screen mounting screws and screen (See Photo 1, below).

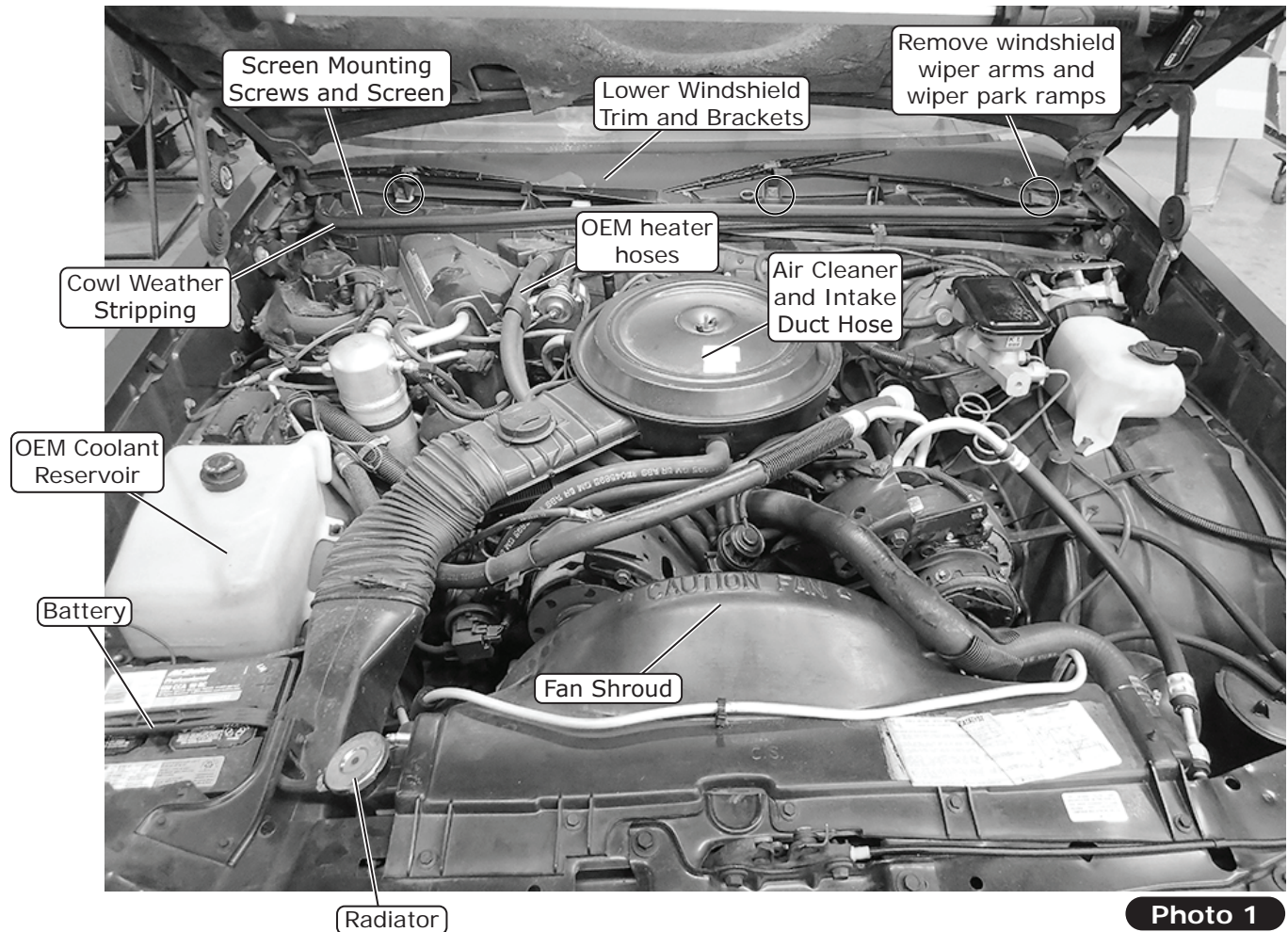



www.vintageair.com

Engine Compartment Disassembly (Cont.)

15. Disconnect all A/C hoses, vacuum and electrical connections from the OEM evaporator (See Photo 3, below).
16. Disconnect the A/C hoses from the OEM compressor, condenser and evaporator (discard) (See Photo 4, below) . **NOTE: Jack up the vehicle and support it with jack stands, then remove the passenger-side front wheel.**
17. Remove the inner fender mounting hardware, then the inner fender. **NOTE: This is necessary to access the evaporator mounting bolts and provide space to remove the OEM evaporator case.**
18. Remove all of the mounting hardware securing the OEM evaporator to the firewall.
19. Remove the ground wire behind the distributor cap.

Remove radiator cooling fan

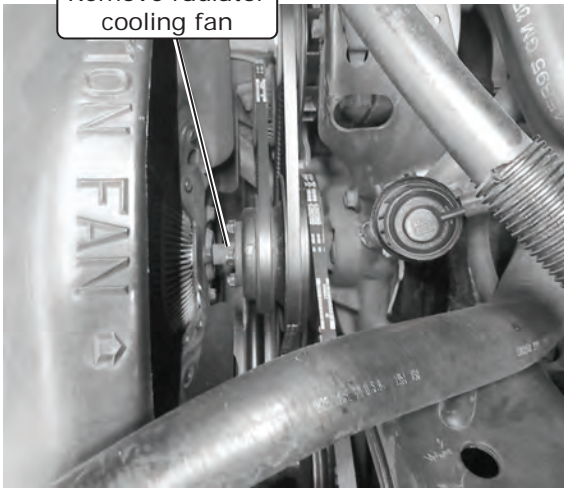

Photo 2

Disconnect electrical connections from OEM evaporator



Photo 3

Disconnect A/C hoses from OEM compressor, condenser and evaporator

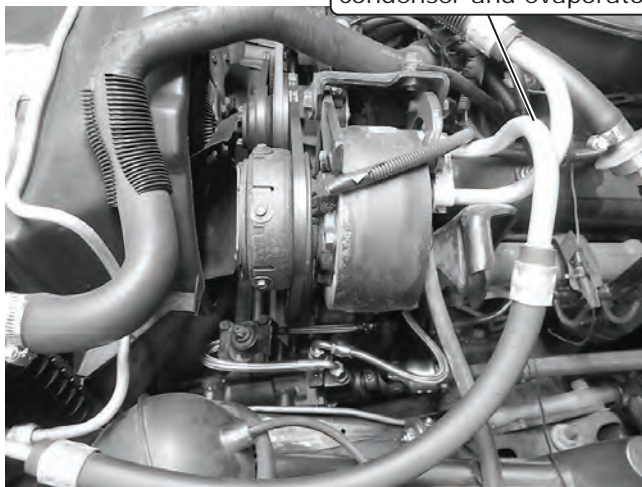

Photo 4



www.vintageair.com

Condenser Assembly and Installation

1. Refer to separate instructions included with the condenser kit to install the condenser.
2. Binary switch installation (Refer to condenser instructions).

Compressor and Brackets

1. Refer to separate instructions included with the bracket kit to install the compressor bracket.

Passenger Compartment Disassembly

NOTE: Removing the front seats will provide extra room for the passenger compartment disassembly process. The removal of the dash is required to remove the OEM duct work from the vehicle. Refer to the vehicle shop manual for more detailed information. Retain OEM bolts, washers and nuts, as some hardware will be reused.

1. Remove the glove box door by removing (4) screws (See Photo 1, below).
2. Remove the control panel/radio bezel by removing (4) screws (See Photo 2, below).
3. Remove the control panel by removing (4) mounting screws (See Photo 3, below) (retain screws).
4. Disconnect the cables, plugs and vacuum lines, then remove the control panel.
5. Remove the radio.
6. Release any clips holding wires to the OEM evaporator.
7. Remove (2) evaporator/duct work mounting screws (See Photo 4, below).
8. Remove the ground wire mounting bolt on the passenger side above the OEM ECU.
9. Remove the OEM evaporator from the vehicle through the engine compartment.
10. Remove the instrument cluster bezel by removing (9) mounting screws (See Photo 5, below).
11. Remove (3) headlight switch bracket screws and unplug switch, then remove (retain).
12. Remove the gear indicator by removing (2) mounting screws, then disconnect the cable.

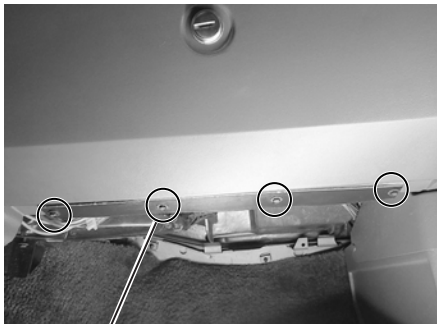

Remove glove box door by removing (4) screws

Photo 1



Remove control panel/radio bezel by removing (4) screws

Photo 2



Remove control panel by removing (4) mounting screws

Photo 3

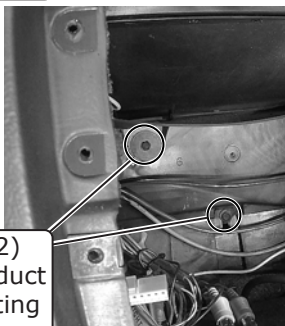

Remove (2) evaporator/duct work mounting screws

Photo 4



Remove instrument cluster bezel by removing (9) mounting screws

Photo 5



www.vintageair.com

Passenger Compartment Disassembly (Cont.)

13. Remove the under-column louver cover by removing (4) screws (See Photo 6, below).
14. Drop the steering column by removing the (2) mounting nuts (See Photo 7, below).
15. Remove the under-column mounting bolt (See Photo 8, below).
16. Remove the driver-side under dash mounting nut (See Photo 9, below).
17. Remove the dash bracket support screw (located behind the radio) (See Photo 10, below).
18. Unplug all wiring connections from the dash.
19. Disconnect the fuse panel from the engine compartment.
20. Remove (4) dash mounting screws ((2) per duct) (See Photo 11, below).
21. Carefully remove the dash from the vehicle.
22. Remove the OEM duct work by removing (5) mounting screws (See Photo 12, below).

Remove under-column louver by removing (4) screws

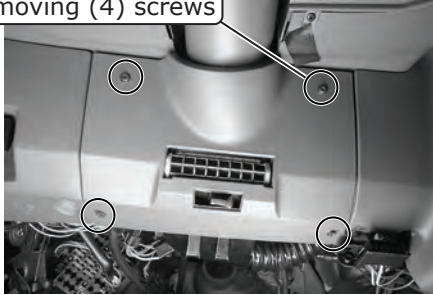

Photo 6

Remove (2) mounting nuts to drop steering column

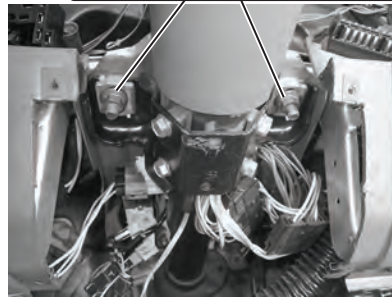

Photo 7

Remove under-column mounting bolt

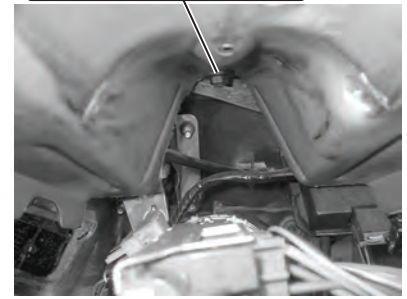

Photo 8

Remove driver-side under dash mounting nut

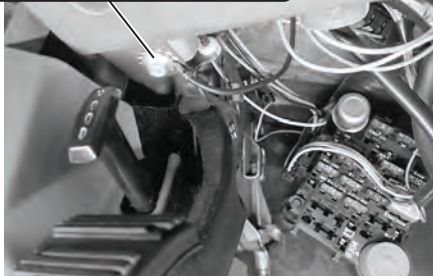

Photo 9

Remove dash bracket support screw



Photo 10

Remove (4) dash mounting screws



Photo 11



Remove OEM duct work by removing (5) mounting screws

Photo 12



www.vintageair.com

Firewall Modification & Insulation

NOTE: The firewall requires modification for the drain hose to be installed. For proper system operation, Vintage Air recommends using heat-blocking insulation in the area around the evaporator unit (firewall, kick panel, inner cowl, firewall covers). Due to tight clearance for the evaporator unit between the firewall and dash, Vintage Air recommends an insulation thickness of no more than 1/4". To ensure a watertight seal between the passenger compartment and the vehicle exterior, for all bolts passing through the firewall, Vintage Air recommends coating the threads with silicone prior to installation.

Perform the following: (For Magnum Kit, proceed to Step 3, Page 11)

1. (Super Magnum Kit Only) Remove the metal tabs from the firewall opening (See Photos 1 and 2, below).
2. (Super Magnum Kit Only) Trim the OEM dash mounting bracket (See Photos 3, 4, 5, and 6, below).

NOTE: To assure the dash mounting bracket has been modified enough to provide proper clearance, the evaporator module may need to be mocked up in the vehicle multiple times. While the evaporator module is in place, loosely install the dashboard and check the passenger-side mounting bracket for clearance. The passenger-side mounting bracket may also need to be modified for fitment (See Photos 7 and 8, below).

Remove metal tabs from firewall opening



Photo 1



Metal Tabs Removed Photo 2

Trim OEM dash mounting bracket



Photo 3



OEM Mounting Bracket Trimmed

Photo 4

Trim OEM dash mounting bracket

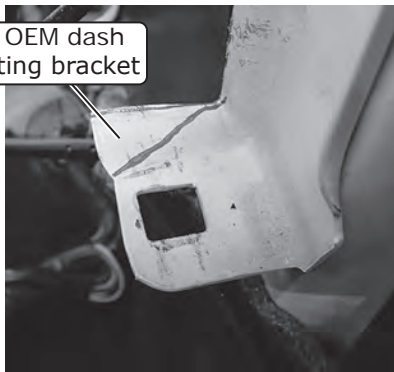
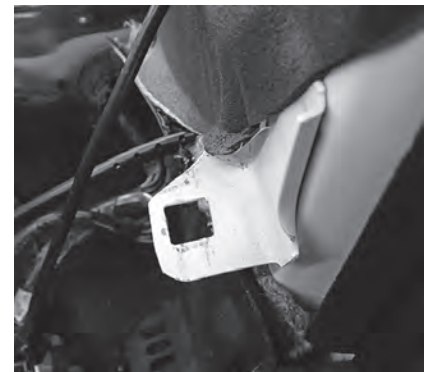

Photo 5



OEM Mounting Bracket Trimmed

Photo 6

Passenger-Side mounting bracket may need to be modify for fitment

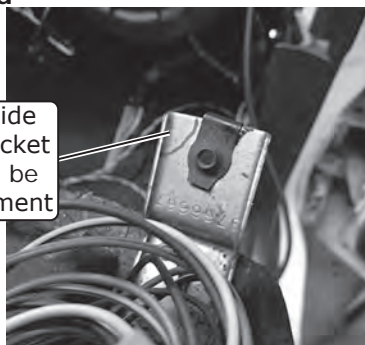

Photo 7



Passenger-Side Mounting Bracket Trimmed

Photo 8



www.vintageair.com

Firewall Modification & Insulation (Cont.)

- Using the bead roll on the floor pan for reference, measure down 1/2" from the firewall (See Photo 9 , below). Mark and drill a 5/8" hole for the drain hose (See Photo 10, below). **NOTE: To ensure a tight fit for the drain hose, do not enlarge the drain hole more than 5/8".**
- Install heat-blocking insulation onto the firewall and firewall cover at this time (See Photos 11 and 12, below).

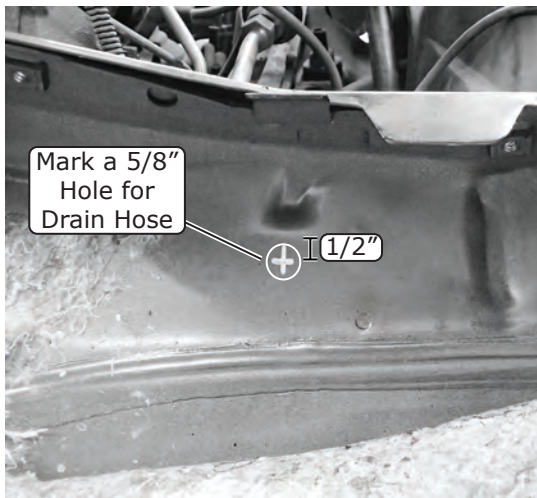

Photo 9

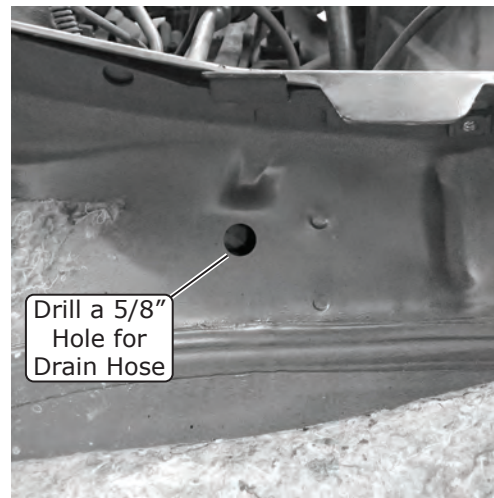

Photo 10

Install heat-blocking insulation onto firewall and firewall cover

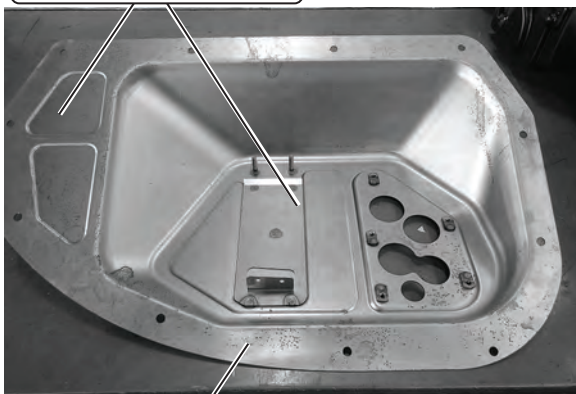

Photo 11

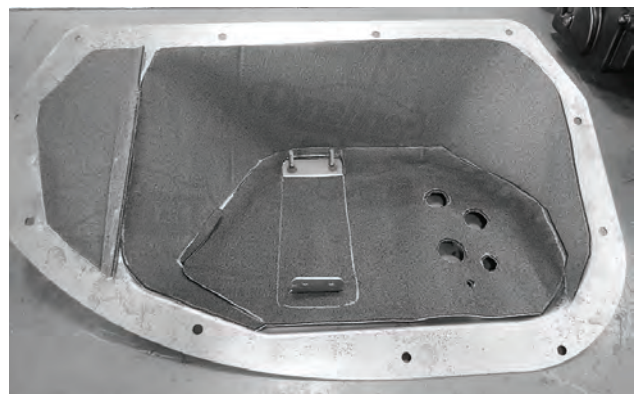

Photo 12



www.vintageair.com

Dash Louver Adapter Preparation

On a workbench, perform the following:

1. Remove the dash trim containing the center and passenger-side louvers (See Photo 1, below).
2. Remove the OEM center vent flange (discard) by removing (2) mounting screws (retain) (See Photo 2, below).
3. Remove the glove box door mounting screw and cable (See Photo 3, below).
4. Install the hose adapter mounting bracket into the 7/64" hole on the sidewall of the hose adapter using a #6 x 1/4" screw (See Photos 4 and 5, below). Apply a bead of silicone around the inner edge of the passenger-side hose adapter and install it over the louver housing. Reinstall the cable and mounting screw into the hose adapter bracket (See Photo 6, below).
5. Apply silicone to the driver-side dash hose adapter, and install it onto the OEM louver housing (See Photo 7, below).
6. Apply silicone to the under-dash louver housing, then install the hose adapter reducer (See Photos 8 and 9, below).



Photo 1

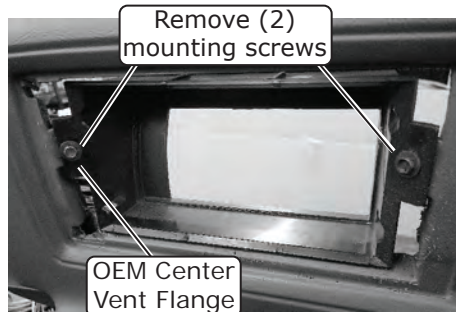

Photo 2

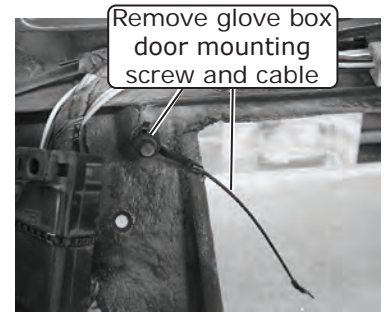

Photo 3

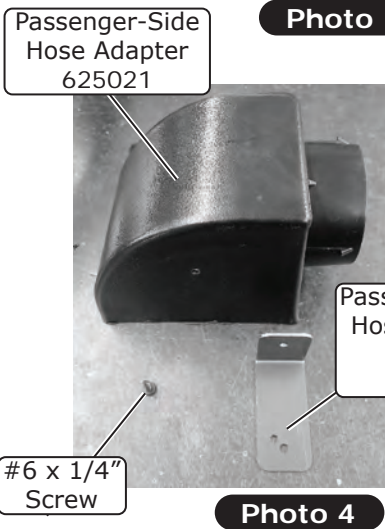

Photo 4

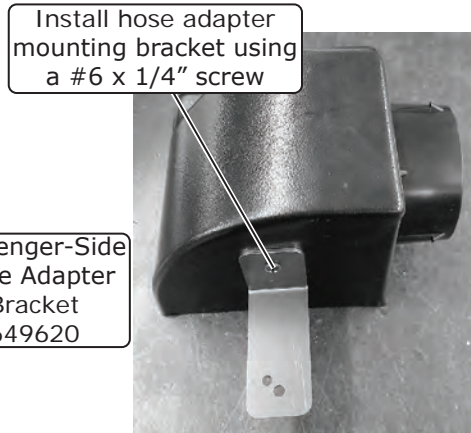

Photo 5

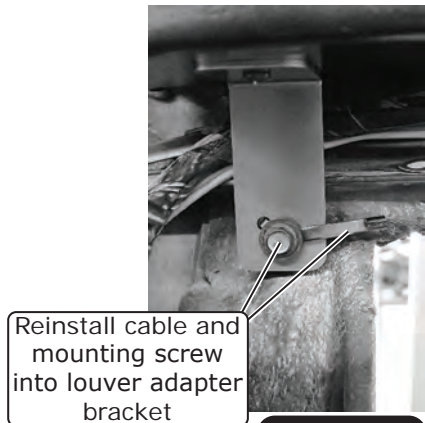

Photo 6



Photo 7

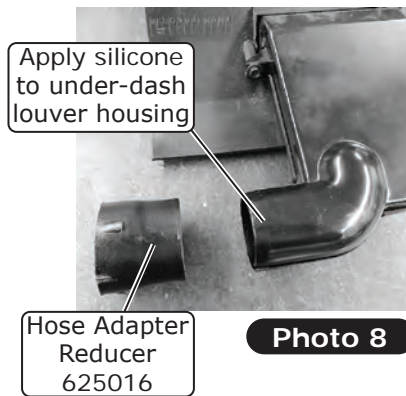

Photo 8



Photo 9



www.vintageair.com

Evaporator Preparation

NOTE: Before fully tightening the hardlines, ensure the hardlines are aligned with the opening on the firewall cover plate as shown in Photo 8, below. Use a back up wrench when tightening fittings.

Perform the following on a workbench:

1. Install (3) 1/2" plastic plugs into the back of the evaporator module (See Photo 1, below). **NOTE:** These mounting provisions will not be used in this application.
2. Using (2) #10 x 5/8" screws, secure the evaporator firewall bracket onto the evaporator module (See Photo 2, below).
3. Using (4) spring clips, install the dash plenum onto the evaporator module as shown in Photos 3 and 4, below.
4. Using (2) spring clips, install the floor plenum onto the back of the evaporator module as shown in Photo 5, below.
5. Using (2) spring clips, install the defrost plenum onto the front of the evaporator module as shown in Photo 6, below.
6. With (2) properly lubricated #10 O-rings (See Lubricating O-rings, Page 22), loosely install the upper and lower heater hardlines (See Photo 7, below).
7. Place the evaporator module into the firewall cover and check the alignment of the heater hardlines (See Photo 8, below). Hardlines should be centered in the firewall cover openings. Once hardlines are centered, remove the firewall cover and tighten both hardlines.

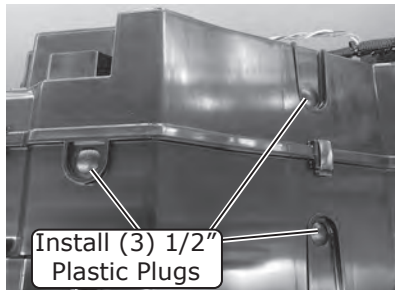

Install (3) 1/2" Plastic Plugs

Photo 1

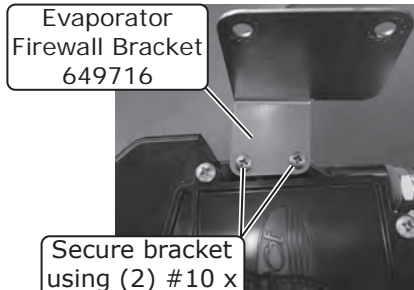

Evaporator Firewall Bracket 649716

Secure bracket using (2) #10 x 5/8" screws

Photo 2

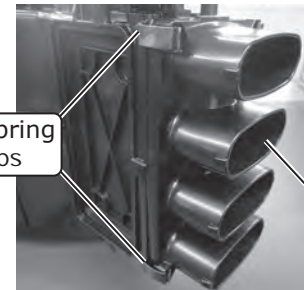

(2) Spring Clips

Dash Plenum 625330

Photo 3

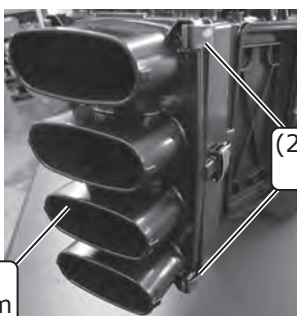

(2) Spring Clips

Dash Plenum 625330

Photo 4

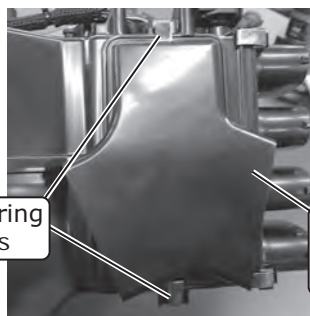

(2) Spring Clips

Floor Plenum 625338

Photo 5

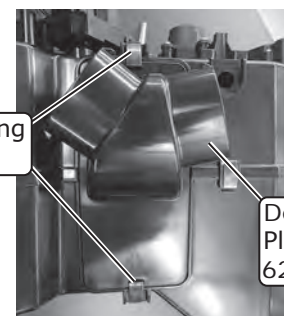

(2) Spring Clips

Defrost Plenum 625331

Photo 6

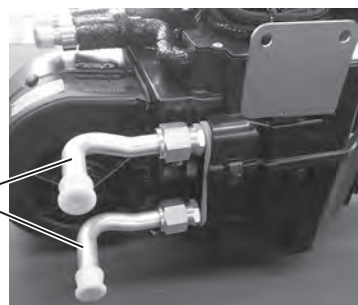

Loosely install (2) heater hardlines with properly lubricated #10 O-rings

Photo 7

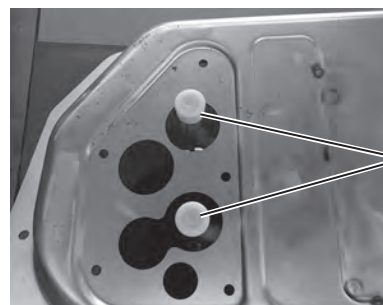

Place evaporator module into firewall cover and center heater hardlines

Photo 8



www.vintageair.com

Evaporator Preparation (Cont.)

8. Remove the (2) #10 x 5/8" screws (discard) securing the ECU to the evaporator module (See Photo 9, below), and let it hang in front of the module.
9. Install (2) nylon bushings onto (2) 8-18 x 5/8" screws, then reinstall them into the top of the evaporator module (See Photos 10 and 11, below). **NOTE: The nylon bushings will ease the reinstallation of the ECU when the evaporator module is fully installed into the vehicle, where there is limited access to the ECU mounting screws.**
10. Place the evaporator module assembly into the firewall cover, then secure the top mount with (2) 1/4-20 locknuts (See Photo 12, below).
11. Secure the firewall cover to the evaporator module lower mount using (2) #10 x 5/8" screws (See Photo 13, below).



Remove (2) #10 x 5/8" screws (discard) securing ECU to evaporator module

Photo 9

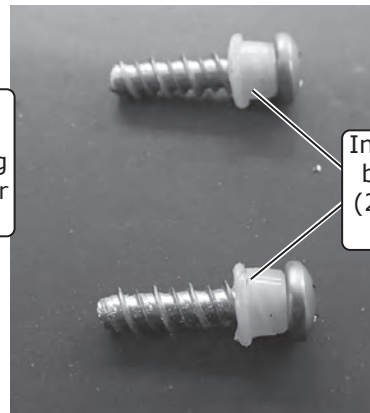

Install (2) nylon bushings onto (2) 8-18 x 5/8" screws

Photo 10

Reinstall (2) 8-18 x 5/8" screws with nylon bushings into top of module

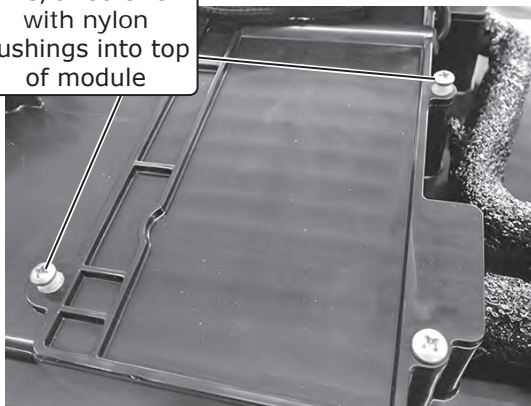
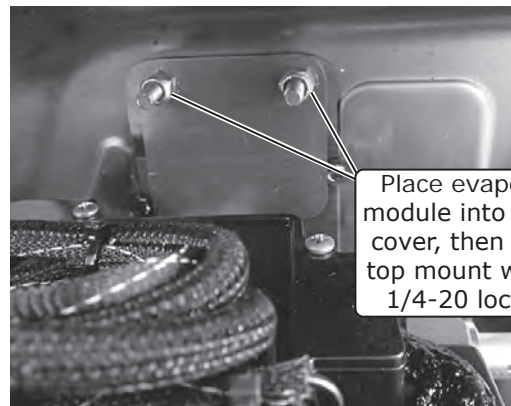
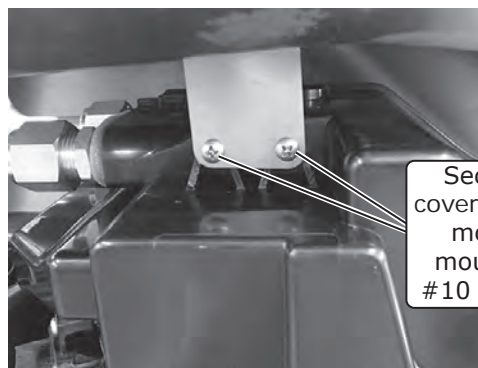

Photo 11



Place evaporator module into firewall cover, then secure top mount with (2) 1/4-20 locknuts

Photo 12



Secure firewall cover to evaporator module lower mount using (2) #10 x 5/8" screws

Photo 13



www.vintageair.com

Evaporator Installation

NOTE: To ensure a watertight seal between the passenger compartment and the vehicle exterior, for all bolts passing through the firewall, Vintage Air recommends coating the threads with silicone prior to installation. To ensure proper drainage, it is very important that the evaporator is level, both left-right and fore-aft. Check for level on the flat portions of the module around the drain (See Photos 8 & 9, Page 16).

1. Remove the OEM dash support bracket by removing the (2) mounting bolts (retain hardware) (See Photo 1, below).
2. Apply silicone to the mating surface of the firewall cover (See Photo 2, below).
3. Install the evaporator assembly onto the firewall opening, and secure it using (11) M6.3 x 16mm hex head screws (See Photos 3 and 4, below). **NOTE: Do not overtighten the screws, as this will cause the firewall cover to warp.**
4. Install the ECU onto the 8-18 x 5/8" screws with nylon bushings (See Photo 5, below).
5. Install (2) 1/4-20 well nuts onto the evaporator module (See Photo 6, below).



Remove OEM dash support bracket by removing (2) mounting bolts

Photo 1

Apply silicone to mating surface of firewall cover

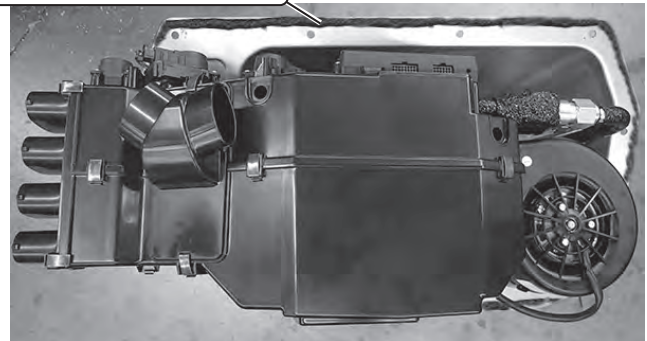

Photo 2

Install evaporator assembly into firewall opening

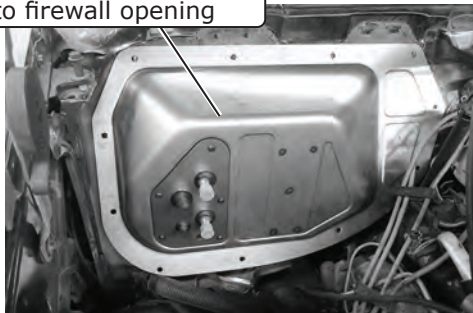

Photo 3

Secure using (11) M6.3 x 16mm hex head screws

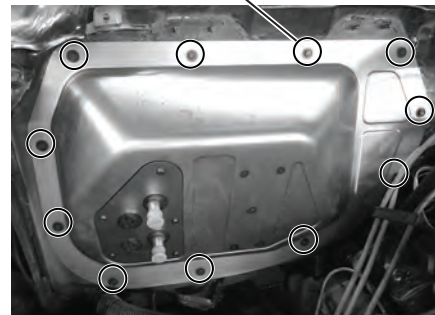

Photo 4

Install ECU onto 8-18 x 5/8" screws with nylon bushings



Photo 5

Install (2) 1/4-20 well nuts onto evaporator module

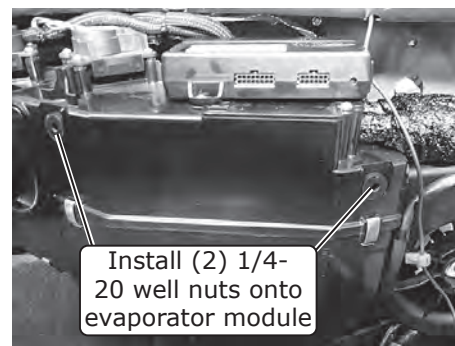

Photo 6



www.vintageair.com

Evaporator Installation (Cont.)

6. Install the evaporator dash bracket using (2) 1/4-20 x 1" serrated flange bolts (See Photo 7, below).
7. Level the evaporator module, both left-right and fore-aft. Check for level on the flat portions of the module around the drain (See Photos 8 & 9, below).
8. Using (2) #12 x 1/2" self-tapping screws, secure the evaporator dash bracket to the firewall (See Photo 7, below).
9. Loosely install the new dash support brace bracket using the OEM hardware (See Photo 10, below).
10. Install a 1/4-20 U-nut onto the dash support brace bracket (See Photo 11, below).

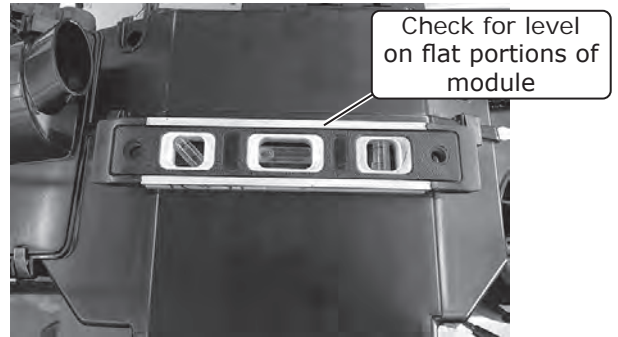
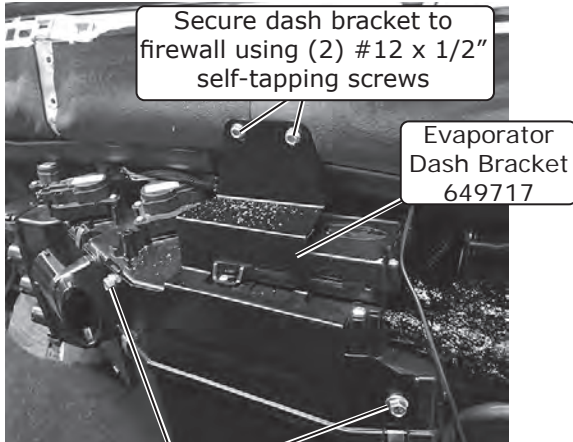

Install evaporator dash bracket using (2) 1/4-20 x 1" serrated flange bolts

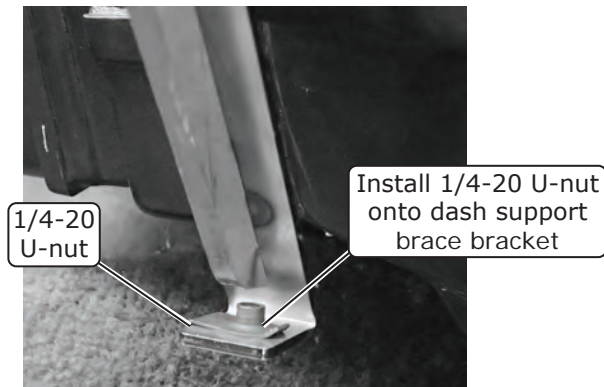
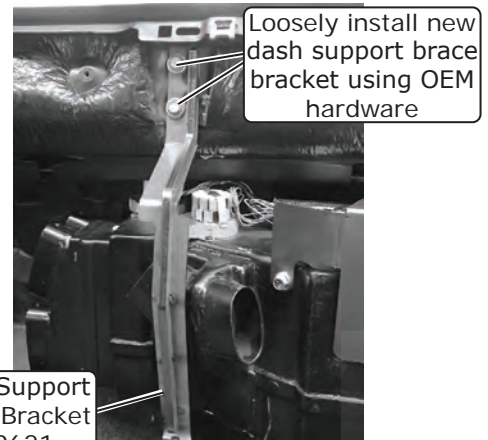
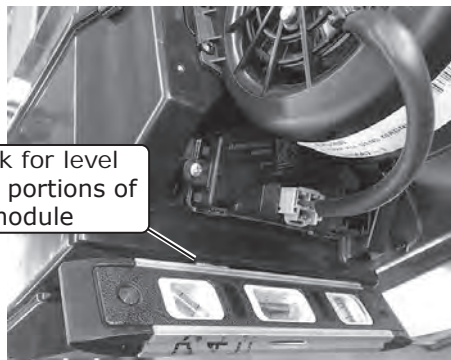



www.vintageair.com

Wiring Installation

1. From the passenger compartment, route the heater control valve plug on the main wiring harness (white/yellow/purple) through the firewall cover (See Photo 1, below).
2. Route the red, white and blue wires from the main wiring harness through the firewall cover (See Photo 2, below). **NOTE: Leave approximately 27" of wiring between the relay and the firewall boot. This allows enough wiring to secure the relay to the mounting position.**
3. Route the heavy gauge orange and white wires through the firewall cover (See Photo 3, below).
4. Connect the blower speed controller plug into the main wiring harness plug (orange and green wires) (See Photo 4, below).

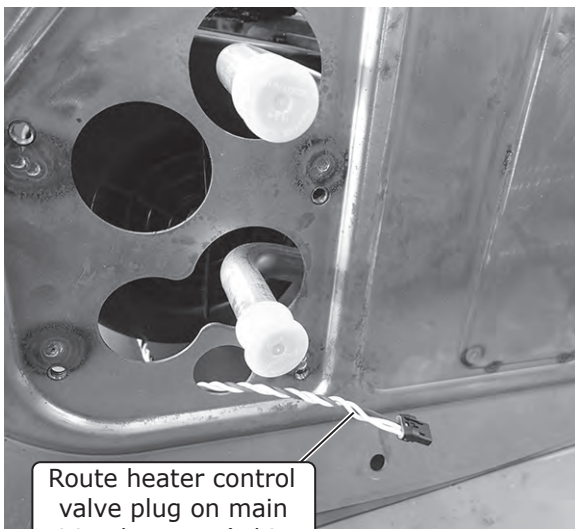

Route heater control valve plug on main wiring harness (white, yellow and purple) through firewall cover

Photo 1

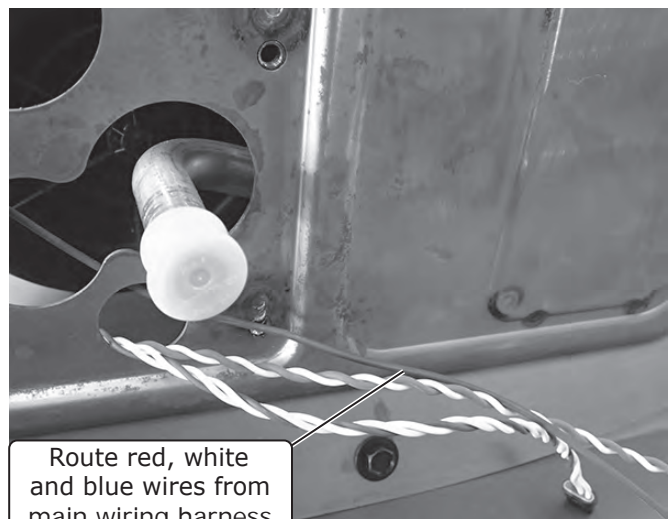

Route red, white and blue wires from main wiring harness through firewall cover

Photo 2

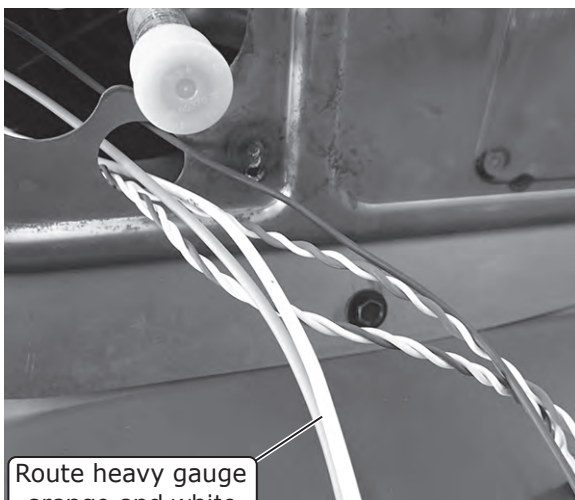

Route heavy gauge orange and white wires through firewall cover

Photo 3

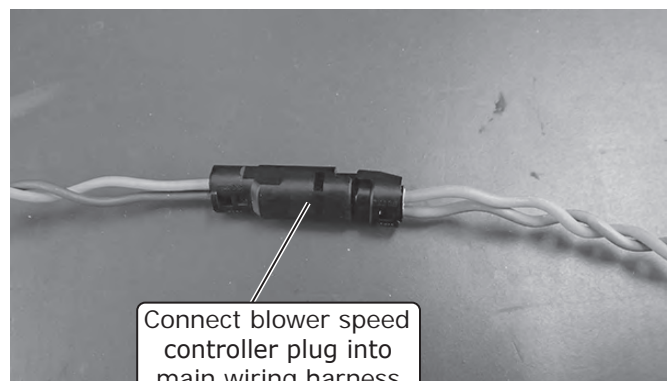

Connect blower speed controller plug into main wiring harness plug

Photo 4



www.vintageair.com

Wiring Installation (Cont.)

5. Select a suitable location for the main relay, then secure it using a #10 x 1/2" sheet metal screw. **NOTE: For Magnum kit, choose a location that does not interfere with the reinstallation of the factory ECU (See Photo 5, below). For Super Magnum kit, the relay may be mounted where the factory ECU was located (See Photo 6, below).**
6. Select a suitable ground location for the white ground wire eyelet from the heater control valve harness, then secure it using a #10 x 1/2" sheet metal screw (See Photo 7, below).
7. Plug the main wiring harness into the ECU (See Photo 8, below).

Choose location that does not interfere with reinstallation of factory ECU

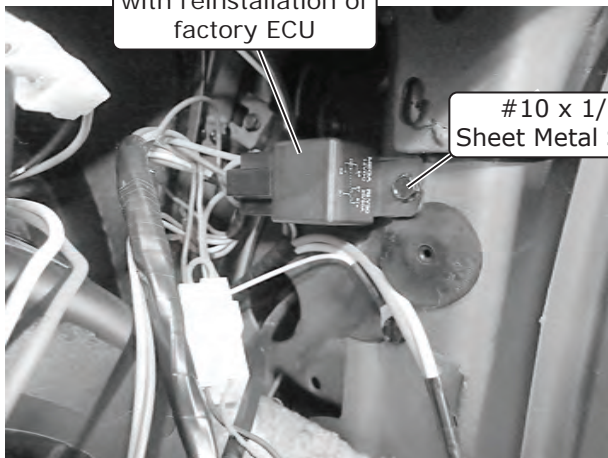

Magnum Kit Relay Mounting

Photo 5

Relay may be mounted where factory ECU was located

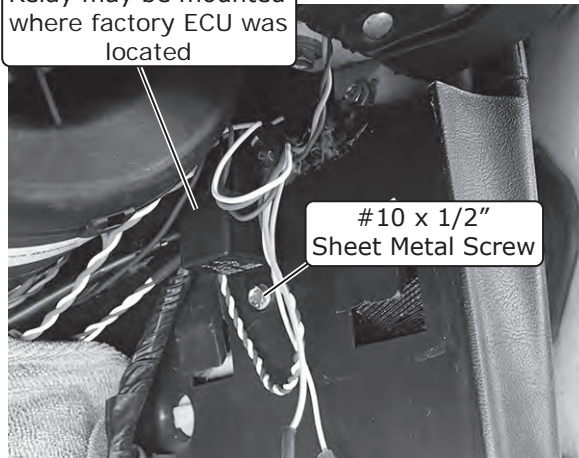

Super Magnum Kit Relay Mounting

Photo 6

#10 x 1/2" Sheet Metal Screw

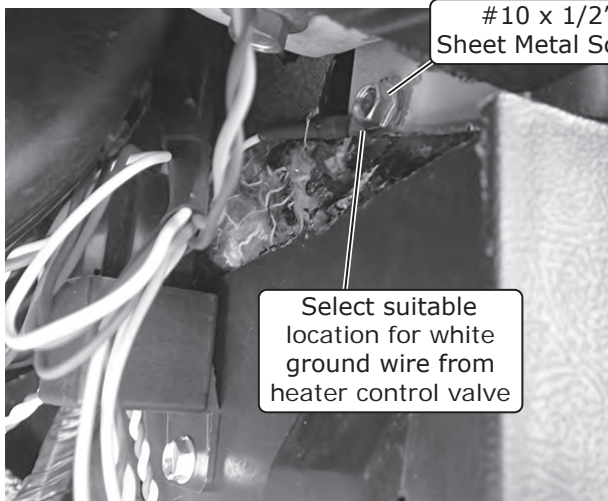

Photo 7

Plug main wiring harness into ECU

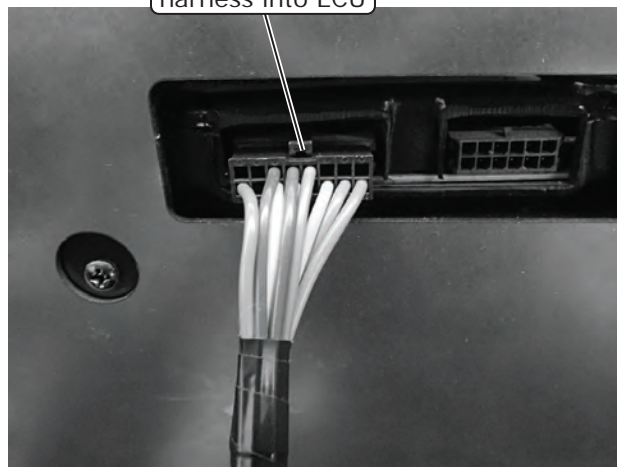

Photo 8



www.vintageair.com

Duct Hose Routing

NOTE: For the system to function optimally, the duct hoses must be routed as directly as possible, taking care to avoid kinks, sharp bends and unnecessary length. Vintage Air supplies duct hoses in continuous lengths that will need to be cut to size depending on application. Before cutting, familiarize yourself with the installation instructions and verify the routing will work with your application. For custom hose routing, additional hose may be needed and can be purchased from Vintage Air.

1. Stretch the duct hose until there is no slack, measure, mark and cut hose to size (See Photo 1, below).

Stretch, measure, mark and cut hose to size



Photo 1

NOTE: To ensure the duct hose will not disconnect from the plenums, use tie wraps or screws to secure them if loose. Once the dash is installed, it will be very difficult to access the duct hoses.

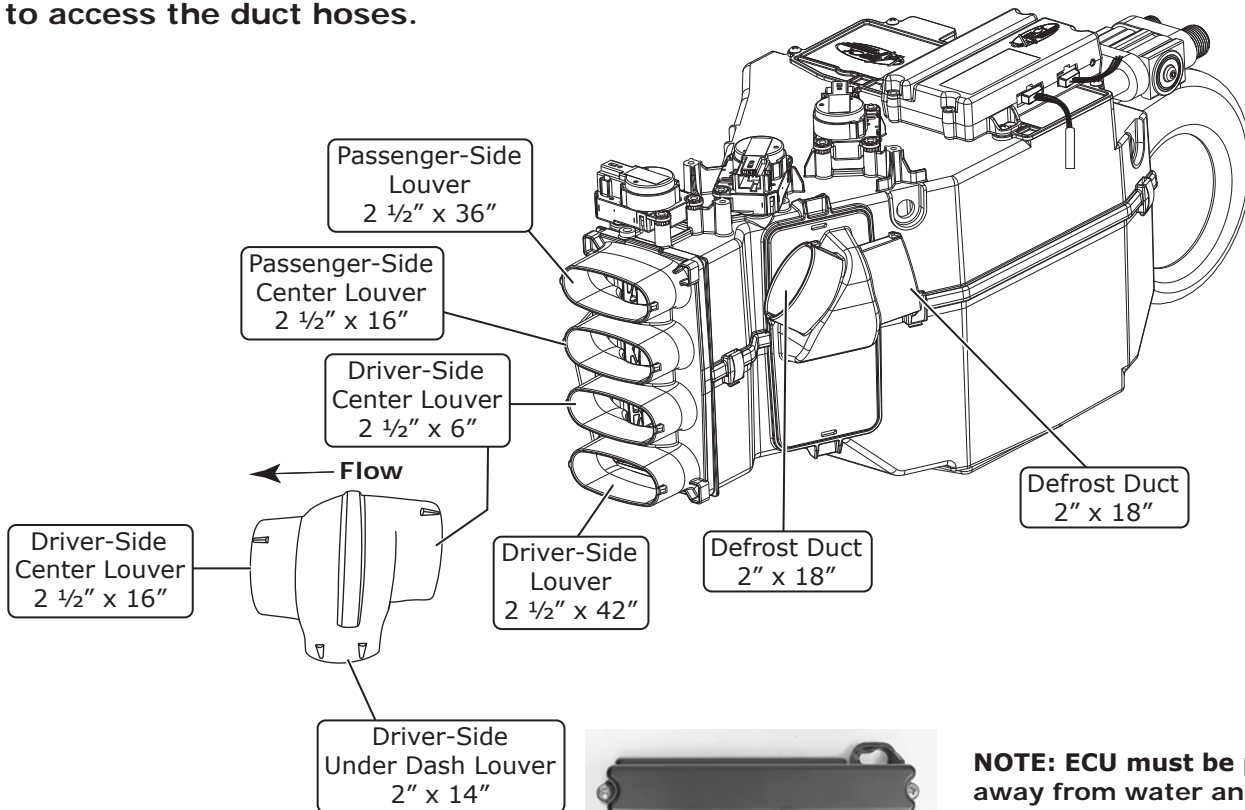

NOTE: ECU must be placed away from water and humidity, and also be accessible for servicing. If relocating, connectors must be positioned towards the bottom.

TECH TIP: Attach the duct hose to the center louver hose adapter before the reinstallation of the dash.



Position connectors towards bottom



www.vintageair.com

Dash, Defrost Duct and Center Hose Adapter Installation

Tech Tip: If the OEM louvers are loose and swivel with no resistance, remove the louver from the OEM louver housing and install a thin piece of foam (See Photo 1, below), then reinstall the louver. This will help restore the louver to normal operation.

1. The courtesy lamp on the passenger side lower dash will need to be relocated due to clearance. Remove the mounting screw and retain the hardware (See Photo 2, below and Courtesy Lamp Relocation, Page 30).
2. Reinstall the dash at this time using the OEM hardware.
3. Secure the dash to the new dash support brace bracket using a 1/4-20 x 1/2" hex bolt and a 9/32" flat washer (See Photo 3, below).
4. Tighten the dash support brace bracket mounting bolts at this time (See Photo 4, below).
5. Secure the steering column with the OEM hardware.
6. Connect all electrical connections that were disconnected during the disassembly process.
7. Install the defrost grilles into the defrost openings (See Photos 5 and 6, below). Insert the defrost ducts over the grille studs, and secure them using (4) 10-24 nuts with star washers ((2) per side) (See Photo 7, below).
NOTE: The hose adapter openings face the center of the vehicle.
8. Install the duct hoses (See Page 19).
9. Install the center louver adapter using the OEM hardware (See Photo 8, below). **NOTE: Installing the duct hoses onto the center louver adapter before installation is recommended due to limited space behind the dash.**

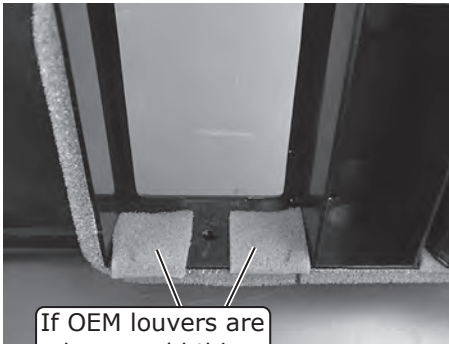

If OEM louvers are loose, add thin pieces of foam

Photo 1

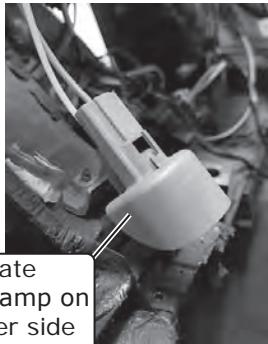

Relocate courtesy lamp on passenger side lower dash for clearance

Photo 2

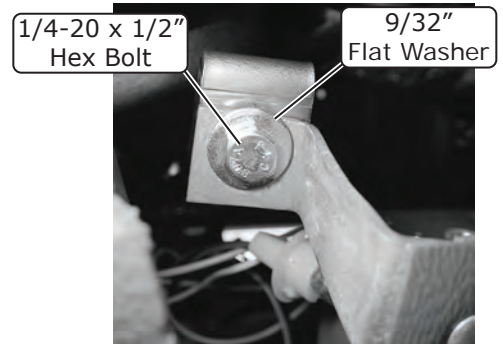

1/4-20 x 1/2" Hex Bolt

9/32" Flat Washer

Photo 3

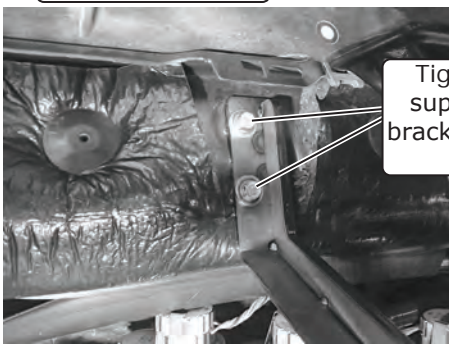

Tighten dash support brace bracket mounting bolts

Photo 4

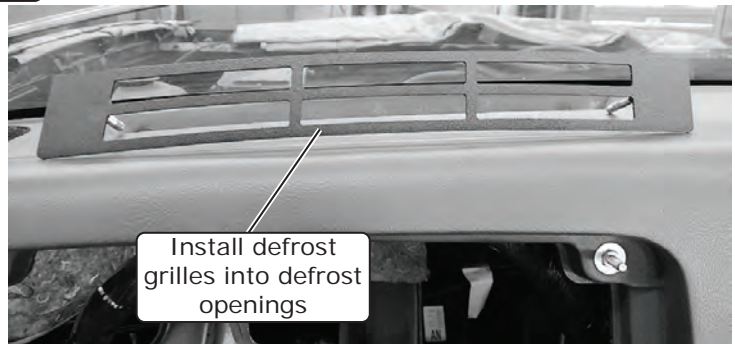

Install defrost grilles into defrost openings

Photo 5



Install defrost grilles into defrost openings

Photo 6

Insert defrost ducts over grille studs



Secure with (4) 10-24 nuts with star washers

Photo 7

Install center louver adapter using OEM hardware

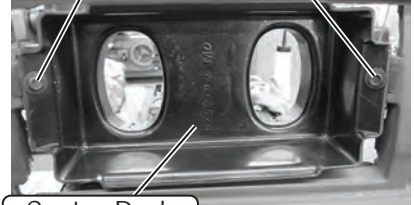

Center Dash Hose Adapter 625014

Photo 8



www.vintageair.com

Dash, Defrost Duct and Center Hose Adapter Installation (Cont.)

10. Reinstall the dash trim containing the OEM louvers (See Photo 9, below).
11. Connect the duct hose to the driver-side louver adapter, then reinstall the gauge cluster and trim, ensuring the speedometer cable and all plugs are connected (See Photo 10, below).
12. Install the 2" duct hose onto the splitter, then to the under column louver hose adapter (See Figure 1, below).
13. Reinstall the under column cover using the OEM hardware (See Photo 11, below).

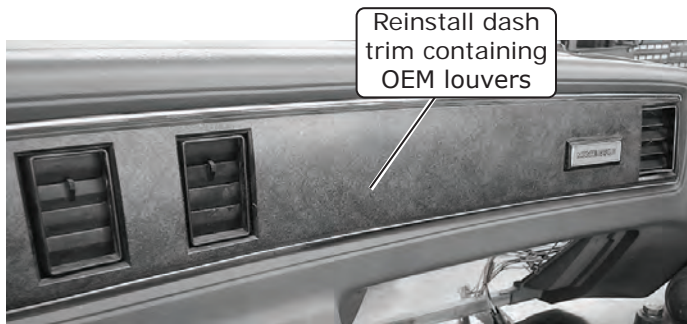

Photo 9

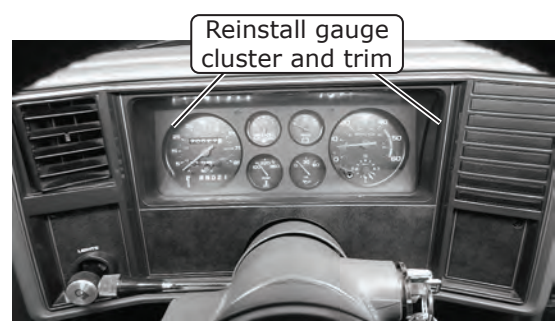

Photo 10

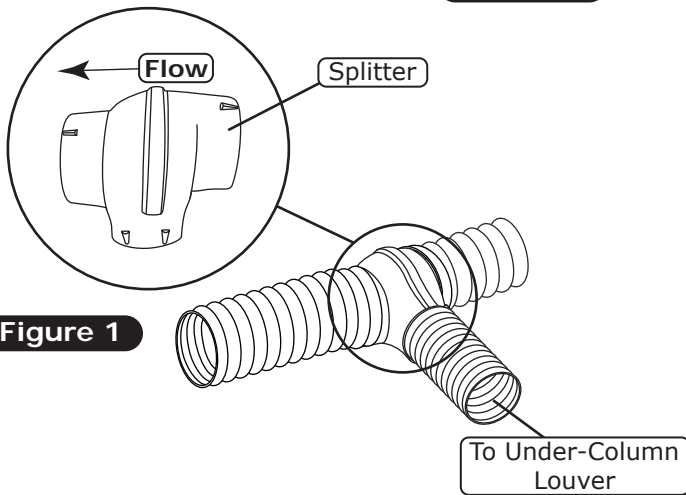

Figure 1



Photo 11

Passenger Compartment Wiring

NOTE: If using the factory wiring for power, the OEM A/C fuse must be changed to a 5 AMP on the fuse panel.

1. Route the violet power wire to a switched 12v power source on the fuse panel.
2. Connect the tan wire to the factory dash lights to enable control panel backlighting.



www.vintageair.com

Control Panel Installation

1. Route the new control panel wiring towards the ECU.
2. Install the control panel into the OEM location using the OEM hardware (See Photo 1, below).
3. Connect the control panel harness plug to the ECU (See Photo 2, below).
4. Reinstall the dash trim (See Photo 3, below).

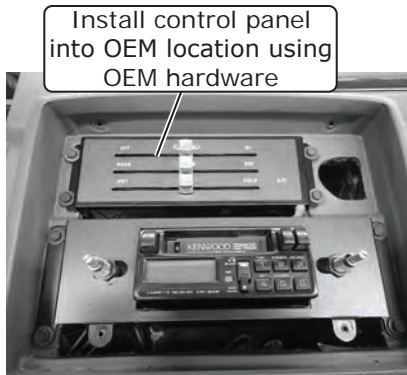

Photo 1

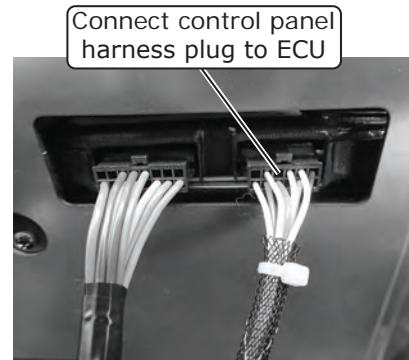

Photo 2

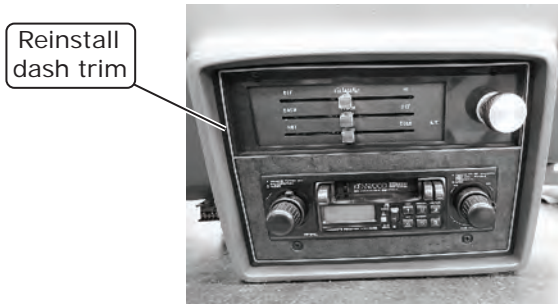
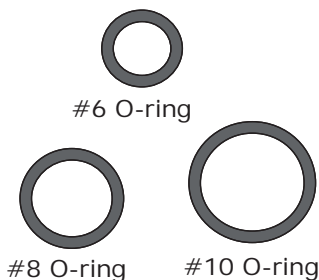

Photo 3

Inner Fender Reinstallation

1. Reinstall the passenger inner fender at this time using the OEM hardware.

Lubricating O-rings



NOTE: Standard torque specifications:
 #6: 11 to 13 ft-lb.
 #8: 15 to 20 ft-lb.
 #10: 21 to 27 ft-lb.

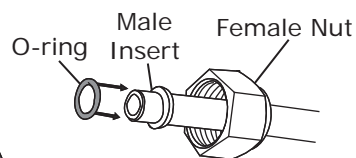

For a proper seal of fittings: Install supplied O-rings as shown and lubricate with refrigerant oil.

Refrigerant Oil for O-rings

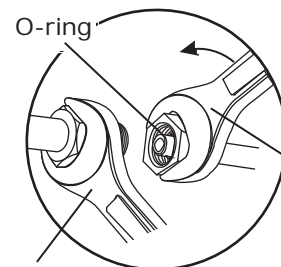
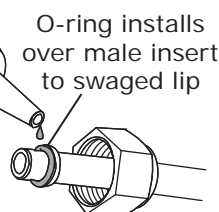

Twist with this wrench

Hold with this wrench



www.vintageair.com

Firewall Cover Boot Plate Installation

1. Route the #10 A/C hose through the firewall cover boot plate and rubber boot (See Photos 1 and 2, below).
2. Route the #6 A/C hose through the firewall cover boot plate and rubber boot (See Photo 3, below).
3. Route all the wiring through the firewall cover boot plate and rubber boot (See Photos 4 and 5, below).
4. Slide the firewall cover boot plate and rubber boot into position over the heater hardlines (See Photos 6 and 7, below).
5. Secure the firewall cover boot plate to the firewall cover using (5) 1/4-20 x 1/2" button head screws (See Photo 8, below).

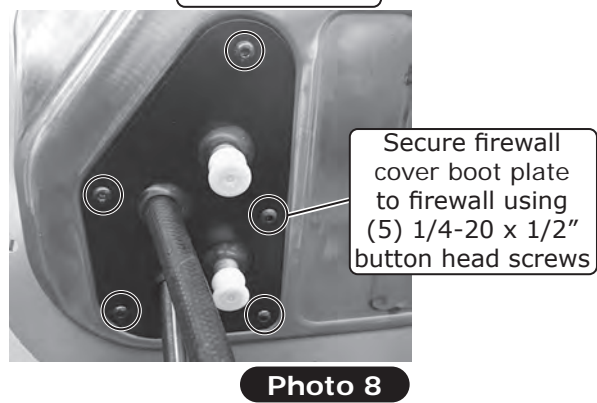
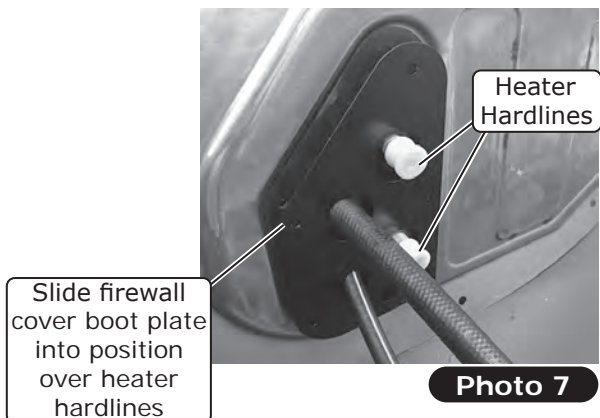
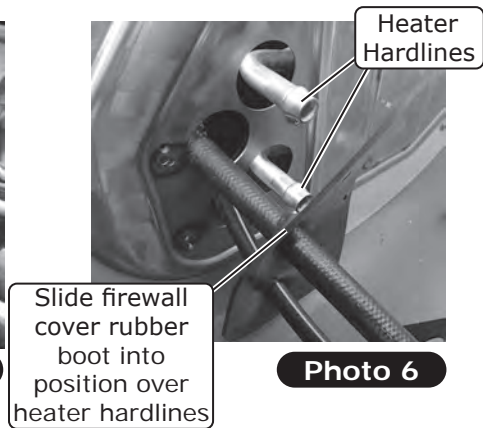
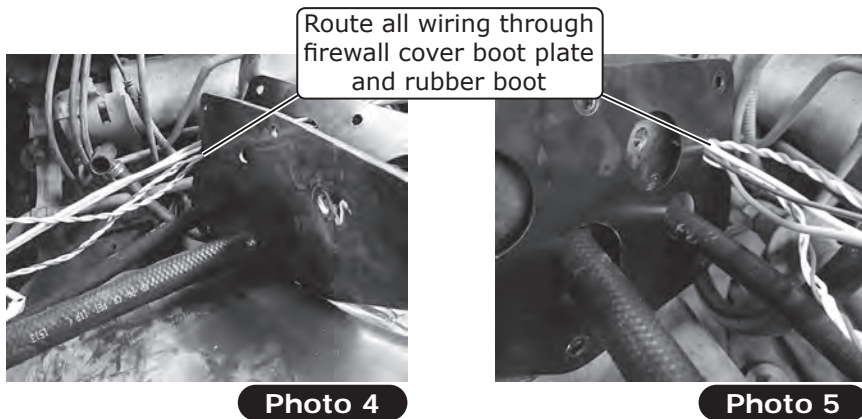
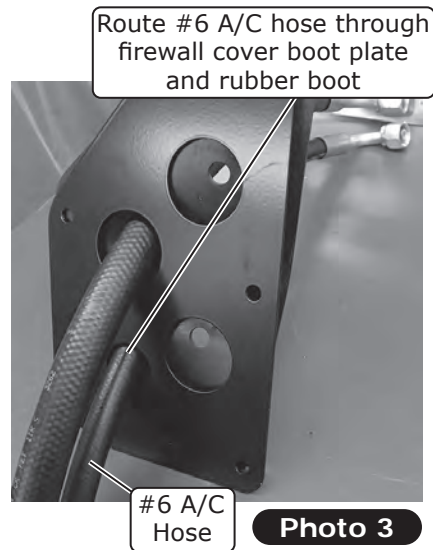
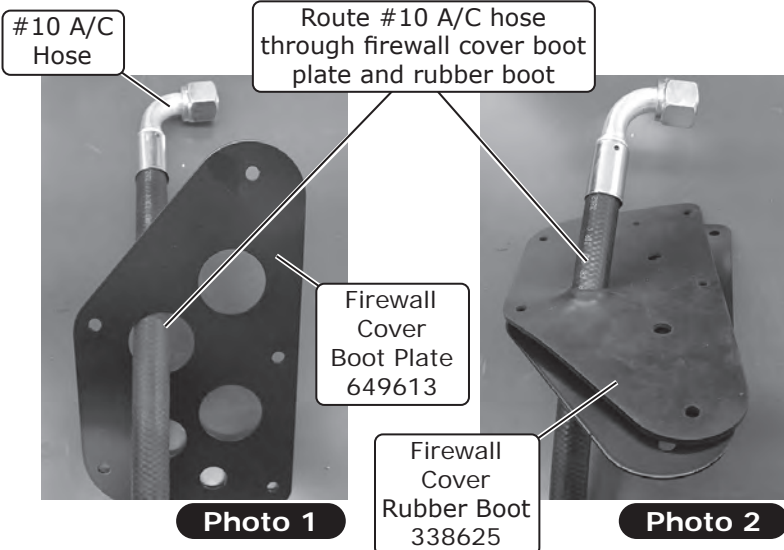



www.vintageair.com

A/C Hose Installation

NOTE: Be sure to use a backup wrench when connecting A/C hoses and hardlines to avoid damaging hose fittings (See Lubricating O-rings, Page 22).

1. With a properly lubricated #10 O-ring (See Lubricating O-rings, Page 22), install the 90° fitting of the #10 A/C hose onto the #10 fitting on the evaporator module expansion valve (See Photo 1, below).
2. With a properly lubricated #6 O-ring (See Lubricating O-rings, Page 22), install the 90° fitting of the #6 A/C hose onto the #6 fitting on the evaporator module expansion valve (See Photo 2, below).
3. Using the supplied press tape, wrap all exposed metal from the A/C hoses to the evaporator module expansion valve as shown in Photo 3, below.

Evaporator module expansion valve



Photo 1

Evaporator module expansion valve

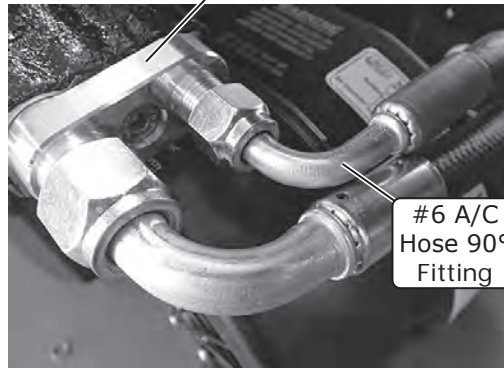

Photo 2

Wrap all exposed metal

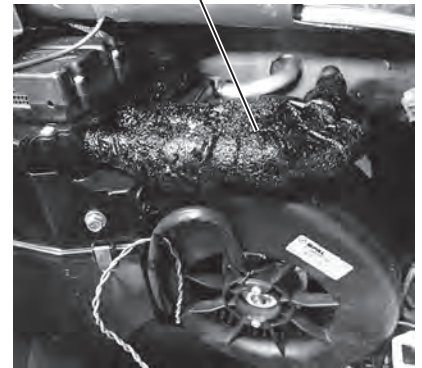

Photo 3

Heater Hose & Heater Control Valve Installation

NOTE: Vintage Air systems use 5/8" heater connections. On engines equipped with 3/4" hose nipples, these will need to be removed and replaced with 5/8" nipples (not supplied). For water pumps with a cast-in 3/4" heater outlet, a 3/4" x 5/8" reducer fitting (not supplied) or molded hose will need to be installed in the heater hose.

1. Route a length of heater hose from the lower heater hardline to the water pump fitting, then secure it using (2) hose clamps (See Photos 1 and 2, below).

Lower heater hardline

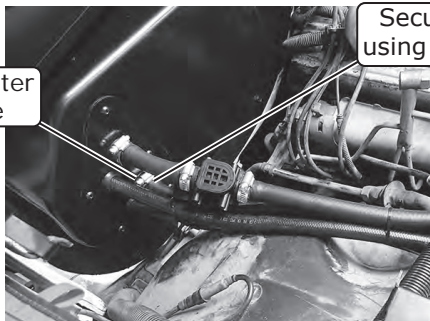
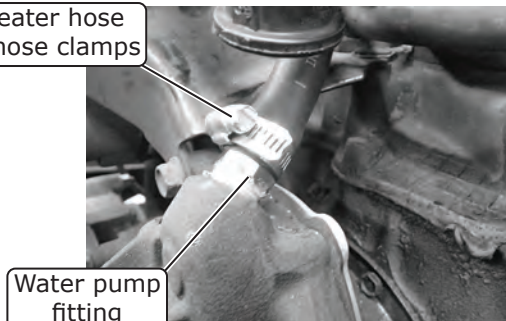

Photo 1

Secure heater hose using (2) hose clamps



Water pump fitting

Photo 2



www.vintageair.com

Heater Hose & Heater Control Valve Installation (Cont.)

2. Cut a length of heater hose approximately 4" to 5" from the firewall cover, then install it onto the upper heater hardline. Install the heater control valve and secure it with (2) hose clamps (See Photo 3, below). **NOTE: Ensure proper flow direction through the heater control valve. The flow direction follows the molded arrow on the valve (See Figure 1, below).**
3. Install another length of heater hose from the heater control valve to the intake, then secure it with (2) hose clamps (See Photos 4 and 5, below).
4. Plug the heater control valve connector into the heater control valve connector wiring harness (See Photo 6, below).

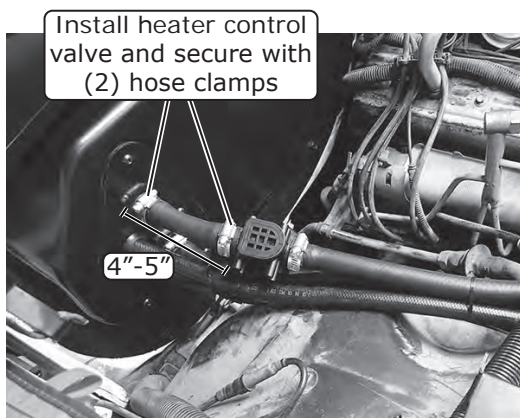

Photo 3

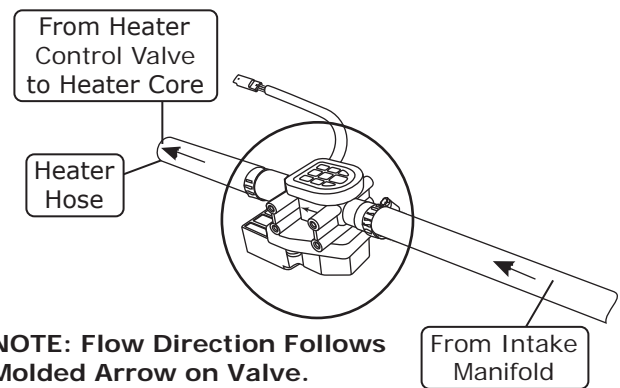

Figure 1

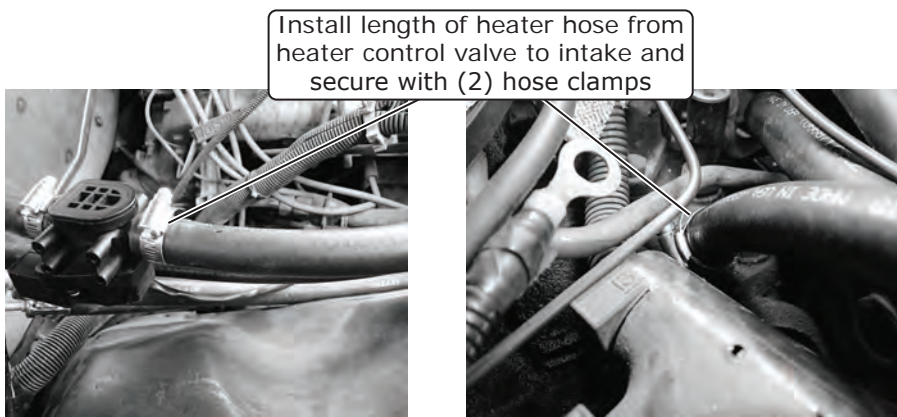

Photo 4

Photo 5

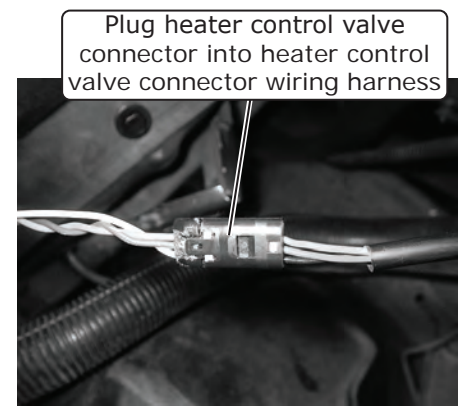
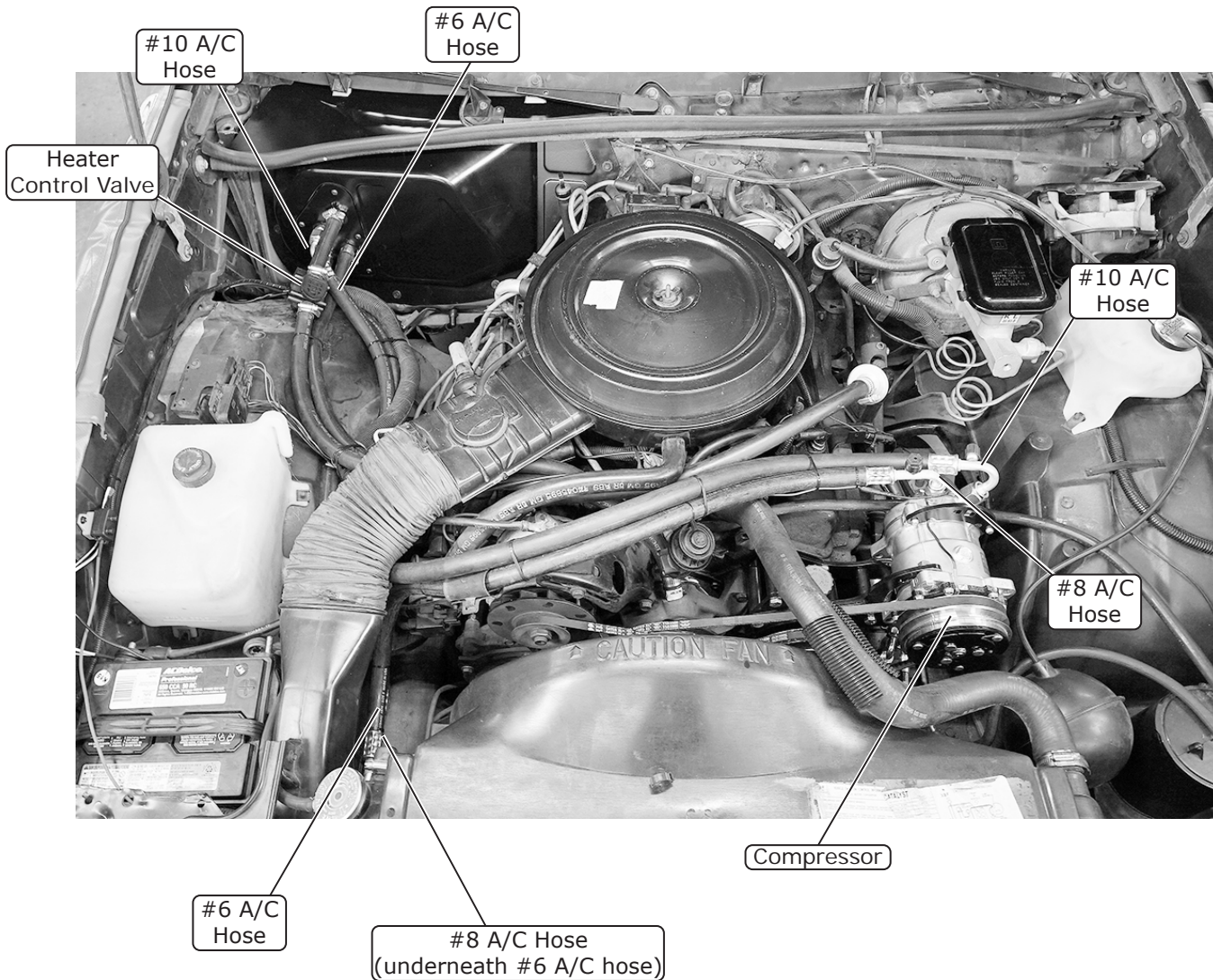

Photo 6



www.vintageair.com

Heater Hose & Heater Control Valve Installation (Final)





www.vintageair.com

Engine Compartment Wiring

1. Route the binary switch wire along the #6 A/C hose toward the battery.
2. Connect the blue wire to the binary switch boot wiring using the supplied butt connector and heat shrink tubing. Cover the safety switch wire with the split sleeve and tie wrap it to the #6 A/C hose (See Photo 1, below).
3. Connect the compressor bullet connector to the compressor lead (See Photo 2, below).
4. Route the compressor lead along the #8 A/C hose toward the core support and secure it with the supplied tie wraps.
5. Connect the compressor lead to the binary switch using the supplied butt connector and heat shrink tubing (See Photo 3, below).
6. Route the power and ground wires toward the battery.
7. Install the supplied heat shrink over the 12 AWG orange fuse holder assembly wire and crimp it to the 12 AWG orange wire from the main wiring harness (See Photo 4, below).
8. Install the supplied heat shrink over the 16 AWG black fuse holder assembly wire and crimp it to the 16 AWG red wire from the main wiring harness (See Photo 5, below).



Cover safety switch wire with split sleeve and tie wrap to #6 A/C hose

Photo 1

Connect compressor bullet connector to compressor lead

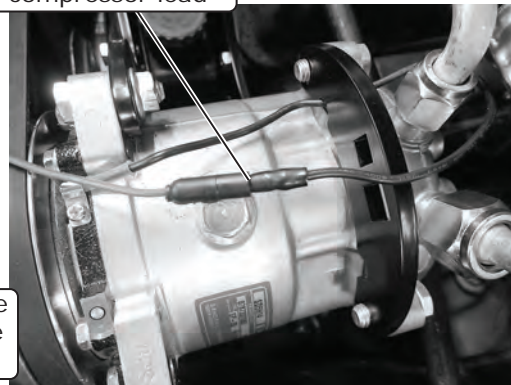

Photo 2

Connect compressor lead to binary switch using supplied butt connector and heat shrink tubing

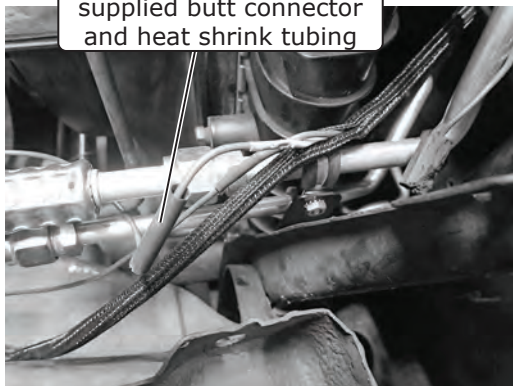

Photo 3

Install supplied heat shrink over 12 AWG orange fuse holder assembly wire and crimp it to 12 AWG orange wire

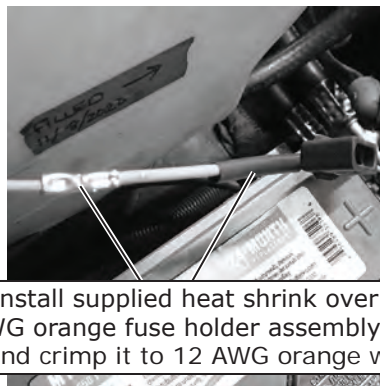

Photo 4

Install supplied heat shrink over 16 AWG black fuse holder assembly wire and crimp it to 16 AWG red wire from main wiring harness



Photo 5



www.vintageair.com

Engine Compartment Wiring (Cont.)

9. Install the fuses into the holders (See Photos 6 and 7, below).
10. Install the supplied heat shrink over the white ground wires, then crimp on the supplied eyelets (See Photos 8 and 9, below).
11. Connect the ground wiring eyelets to the negative battery terminal connector.
12. Connect the positive wiring eyelet to the positive battery terminal connector. **NOTE: Do not connect power until the installation is completed.**
13. Wrap exposed wiring using the supplied split sleeve.



Photo 6

Install fuses into holders

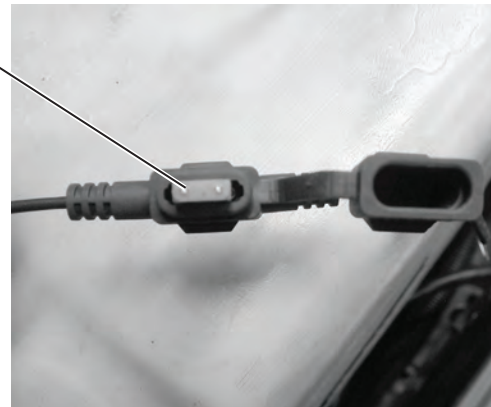

Photo 7

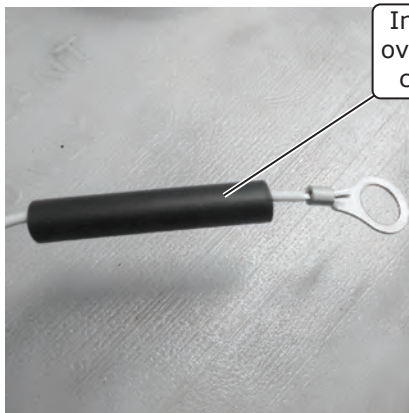

Photo 8

Install supplied heat shrink over white ground wires and crimp on supplied eyelets

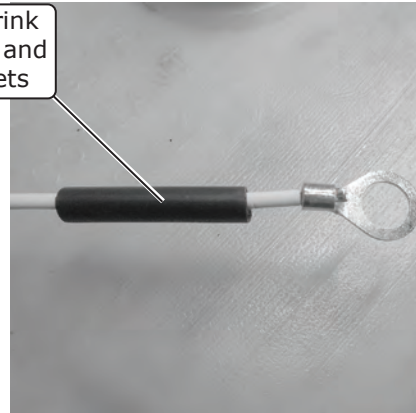

Photo 9



www.vintageair.com

Water Deflector Installation

NOTE: The hood weather stripping may have to be trimmed to fit correctly.

1. Remove the windshield washer nozzle from the OEM bracket.
2. Secure the windshield washer nozzle onto the new washer nozzle bracket using a 10-32 x 1/2" screw and a 10-32 nut with star washer (See Photos 1 and 2, below).
3. Install the windshield washer nozzle assembly onto the water deflector using (2) 10-32 x 1/2" screws and (2) 10-32 nuts with star washers (See Photos 3 and 4, below).
4. Install the water deflector using OEM trim brackets and hardware.
5. Route the windshield water nozzle hose as shown in Photo 5, below, and reconnect it onto the washer nozzle.
6. Reinstall the hood weather stripping (use silicone if needed) (See Photo 6, below).
7. Reinstall the lower windshield trim using the OEM hardware.
8. Reinstall the windshield wiper arms.

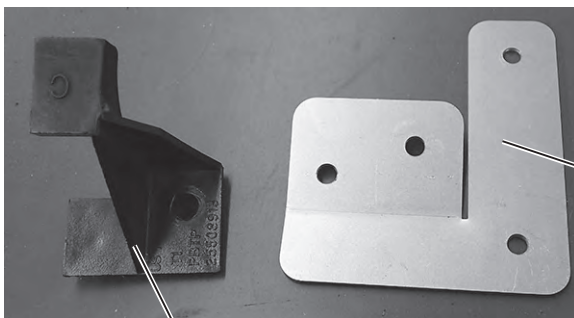

Windshield Washer Nozzle

Photo 1

Windshield Washer Nozzle Bracket 649631

Secure washer nozzle to bracket using a 10-32 x 1/2" screw and a 10-32 nut with star washer

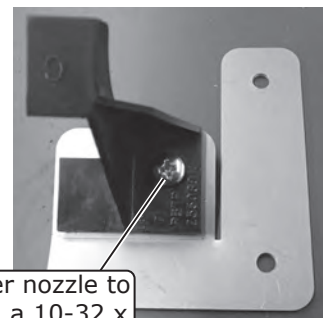
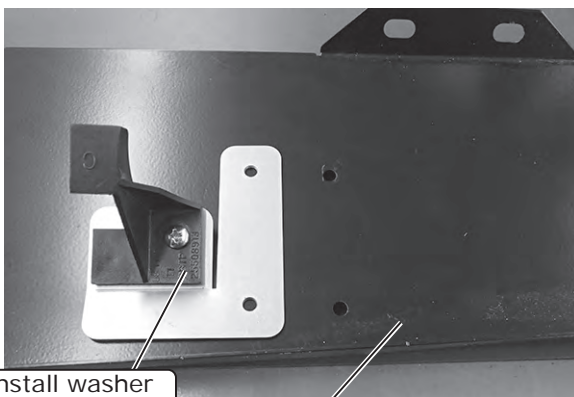

Photo 2



Install washer nozzle assembly onto water deflector

Water Deflector 649606

Photo 3



Secure using (2) 10-32 x 1/2" screws and (2) 10-32 nuts with star washers

Photo 4

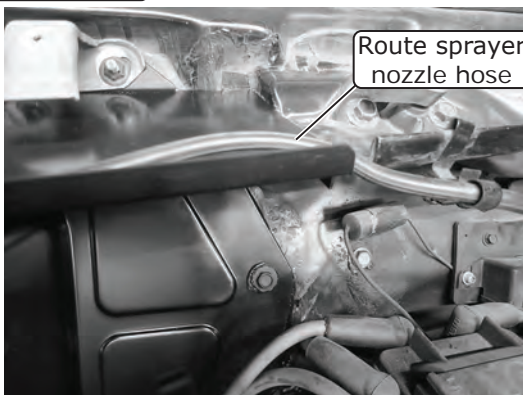

Route sprayer nozzle hose

Photo 5



Reinstall hood weather stripping

Photo 6



www.vintageair.com

Drain Hose Installation

1. Cut the drain hose at 9" (See Photo 1, below). Install the 1/2" drain elbow and the remainder of the hose. Install the 9" piece of drain hose through the pre-drilled hole in the firewall from the engine compartment (See Photo 2, below), then connect the drain hose to the drain outlet on the evaporator unit (See Photo 3, below). In the engine compartment, route the drain hose away from the exhaust. **NOTE: Carpet may need to be trimmed.**

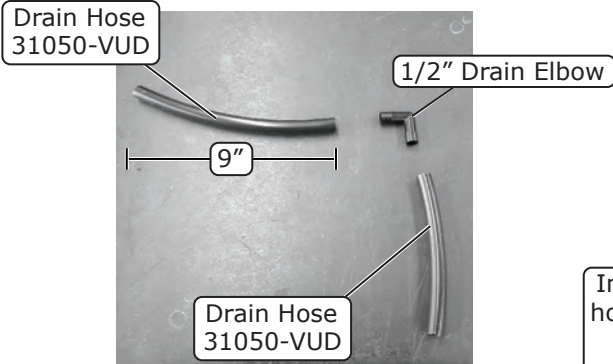

Photo 1

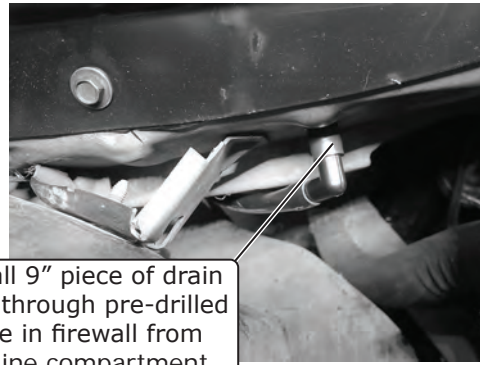

Photo 2

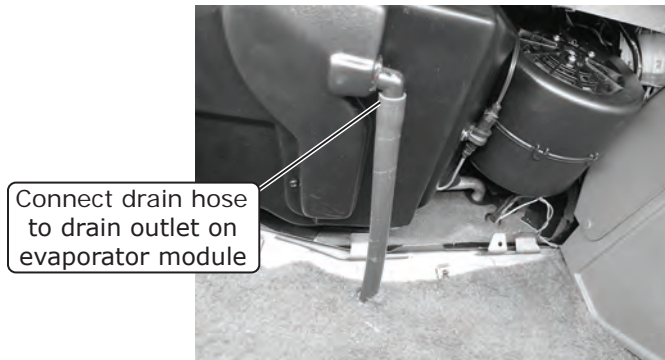

Photo 3

Courtesy Lamp Relocation (If Equipped)

1. Install the courtesy lamp bracket onto the lamp using the OEM hardware (See Photo 1, below).
2. Using a #8 x 1/2" pan head screw, install the lamp using the mounting hole on the bottom of the evaporator module (See Photos 2 and 3, below).

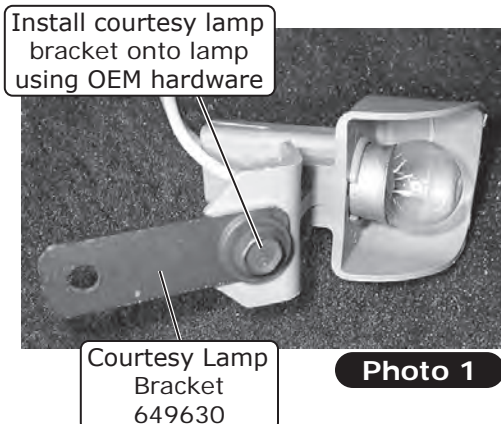

Photo 1



Photo 2



Photo 3



www.vintageair.com

OEM ECU Relocation (Super Magnum Only)

1. When installing the Gen 5 Super Magnum kit, the OEM ECU will have to be relocated from it's factory location. When designing this kit, the OEM ECU was relocated under the evaporator module on the passenger side, under the carpet (See Photo 1, below).

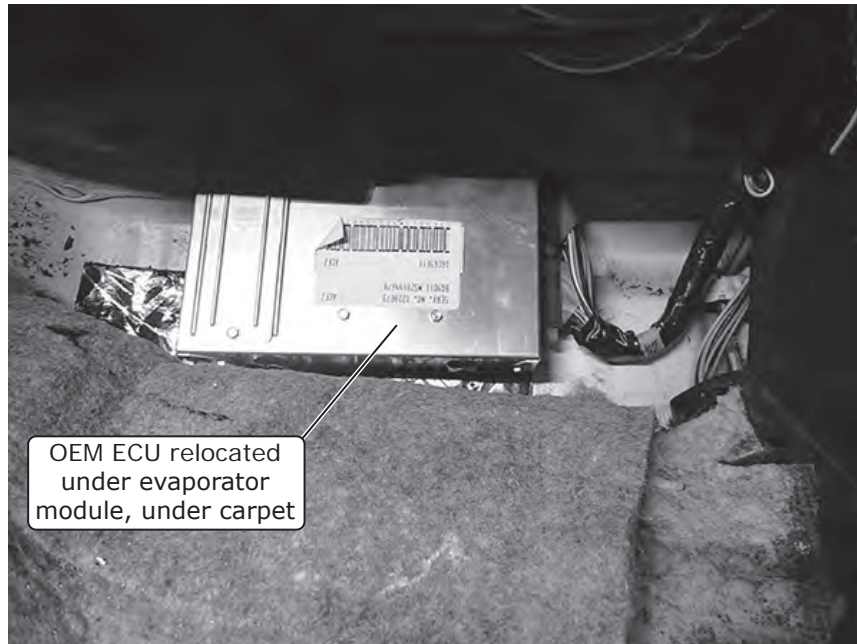



www.vintageair.com

Final Steps: Installation Check

Installation Check	
ITEM TO CHECK	Procedure
<input type="checkbox"/>	ECU If no blinking is observed after 1 minute of turning the ignition on, go to the next check. If repetitive blinking is observed, go to the Advanced Diagnostics Section to diagnose.
<input type="checkbox"/>	Blower speed control Set the blower speed control to OFF , <u>confirm that the blower is off</u> . Position the blower speed control to LOW then MEDIUM and then HIGH . <u>At each setting confirm that the blower speed increases</u> , do this by feeling for the amount of air coming from the unit and hearing the blower speed increase.
<input type="checkbox"/>	Mode control Set the MODE control to the DASH position. <u>Confirm that air is being blown at the dash vents</u> . Set the MODE control to the FLOOR position. <u>Confirm that air is being blown at the floor vents</u> . Set the MODE control to the DEFROST position. <u>Confirm that all air is being blown from the defrost vents</u>
<input type="checkbox"/>	Temperature control if heater lines are installed: Set the MODE control to the DASH position. Set the TEMP control to the MAX HEAT position. <u>Confirm that HOT air is coming from the dash vents</u> . if system is charged: Set the TEMP control to the MAX COOL position. <u>Confirm that COLD air is coming from the dash vents</u> . Also <u>confirm that the compressor "clicks" on</u> when adjusting the TEMP control from the MAX HEAT position to the MAX COOL position.
<input type="checkbox"/>	AC Indicator (if applicable) While the MODE control is set to the DASH position, and the TEMP control is set to the MAX COOL/MIN HEAT position, <u>confirm that the blue AC Indicator light is on</u> .
<input type="checkbox"/>	Backlight (if applicable) If your control panel has backlight capabilities and has been wired, turn the dash lamp on and <u>confirm that the AC panel's legend is lit</u> .
<input type="checkbox"/>	Fittings Verify AC and Heater fittings are all tight.



www.vintageair.com

Glove Box Modification and Installation (Style 1)

1. Using the template, mark and cut the glove box (See Photos 1, and 2, below).
2. Install the glove box cap over the trimmed area. Using the (2) bottom holes on each side of the cap, drill (4) small pilot holes onto the glove box, then secure the cap using (4) #6 x 3/8" pan head screws (See Photo 3, below).
3. Reinstall the glove box/door using the OEM hardware.



Photo 1



Cut Glove Box

Photo 2

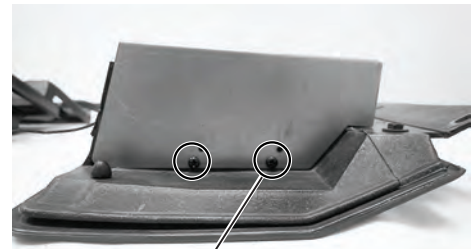
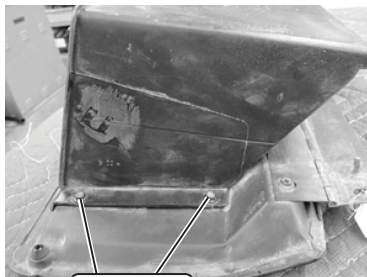

Photo 3

Glove Box Modification and Installation (Style 2)

1. For glove boxes that mount to the door with OEM screws (See Photo 1, below), use the template to mark and cut the glove box (See Photos 2 and 3, below).
2. Install the glove box cap over the trimmed area. Using the (2) upper holes (See Photo 4, below), drill (2) small pilot holes onto the glove box, then secure the cap using (4) pop rivets, ((2) per side) (See Photos 5 and 6, below).
3. Reinstall the glove box/door using the OEM hardware.



OEM Screws

Photo 1



Photo 2



Cut Glove Box Shown

Photo 3

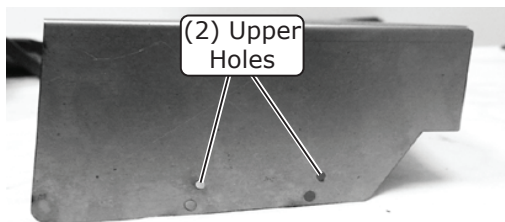

Photo 4

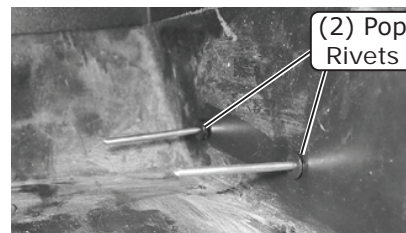

Photo 5

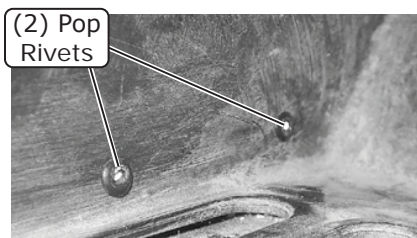
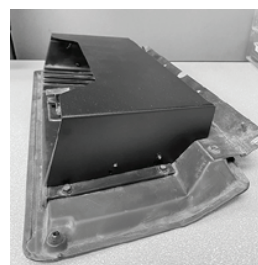

Photo 6



Final Install



www.vintageair.com

Final Steps: Completing the Install

1. If using the OEM A/C power wire to connect to the violet power wire from the main harness, remove the fuse for the factory A/C from the fuse panel and replace it with the supplied 5 amp fuse.
2. Reinstall all previously removed items.
3. Fill radiator with at least a 50/50 mixture of approved antifreeze and distilled water. It is the owner's responsibility to keep the freeze protection at the proper level for the climate in which the vehicle is operated. Failure to follow antifreeze recommendations will cause heater core to corrode prematurely and possibly burst in A/C mode and/or freezing weather, voiding your warranty.
4. Double-check all fittings, brackets and belts for tightness.
5. Vintage Air recommends that all A/C systems be serviced by a licensed automotive A/C technician.
6. Evacuate the system for a minimum of 45 minutes prior to charging, and perform a leak check prior to servicing.
7. Charge the system to the capacities stated on Page 4 of this instruction manual.
8. See Operation of Controls procedures on Page 38.

Quality Crimp Guideline

Acceptable strip length
(Some copper visible)

Crimped area is centered
on each side of splice

Bad strip length
(Too much copper visible)
Visible copper should be
just enough to ensure
clearance between splice
area and wire insulation

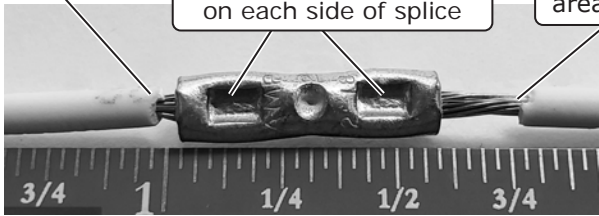

Photo 1

A good crimp requires
seam of butt splice to be
opposite of crimp die tooth

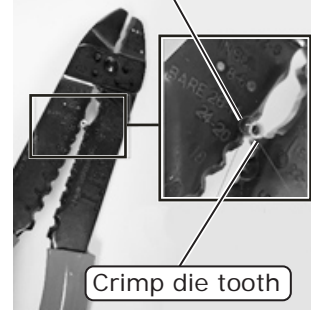

Photo 2

Good Ring Terminal Crimp Bad Ring Terminal Crimp



Crimped
area is
opposite
of seam

Photo 3

Crimp
area is
centered
on barrel

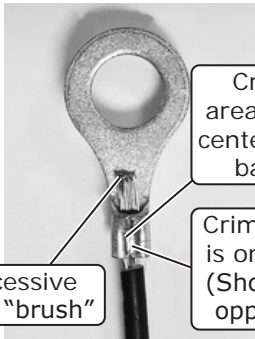

Crimp
area is not
centered on
barrel

Excessive
wire "brush"

Crimp
area
is on seam
(Should be
opposite)

Photo 4



Photo 5

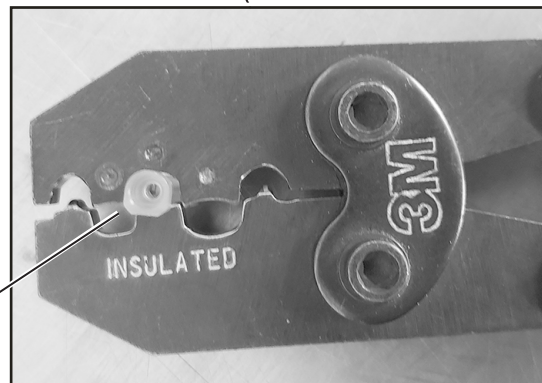

Photo 5a

Use a ratcheting crimp tool
for insulated barrel terminals
when crimping the provided
female insulated terminal.
Ensure terminal is inserted in
appropriate position before
crimping.



www.vintageair.com

Gen 5 Wiring Diagram

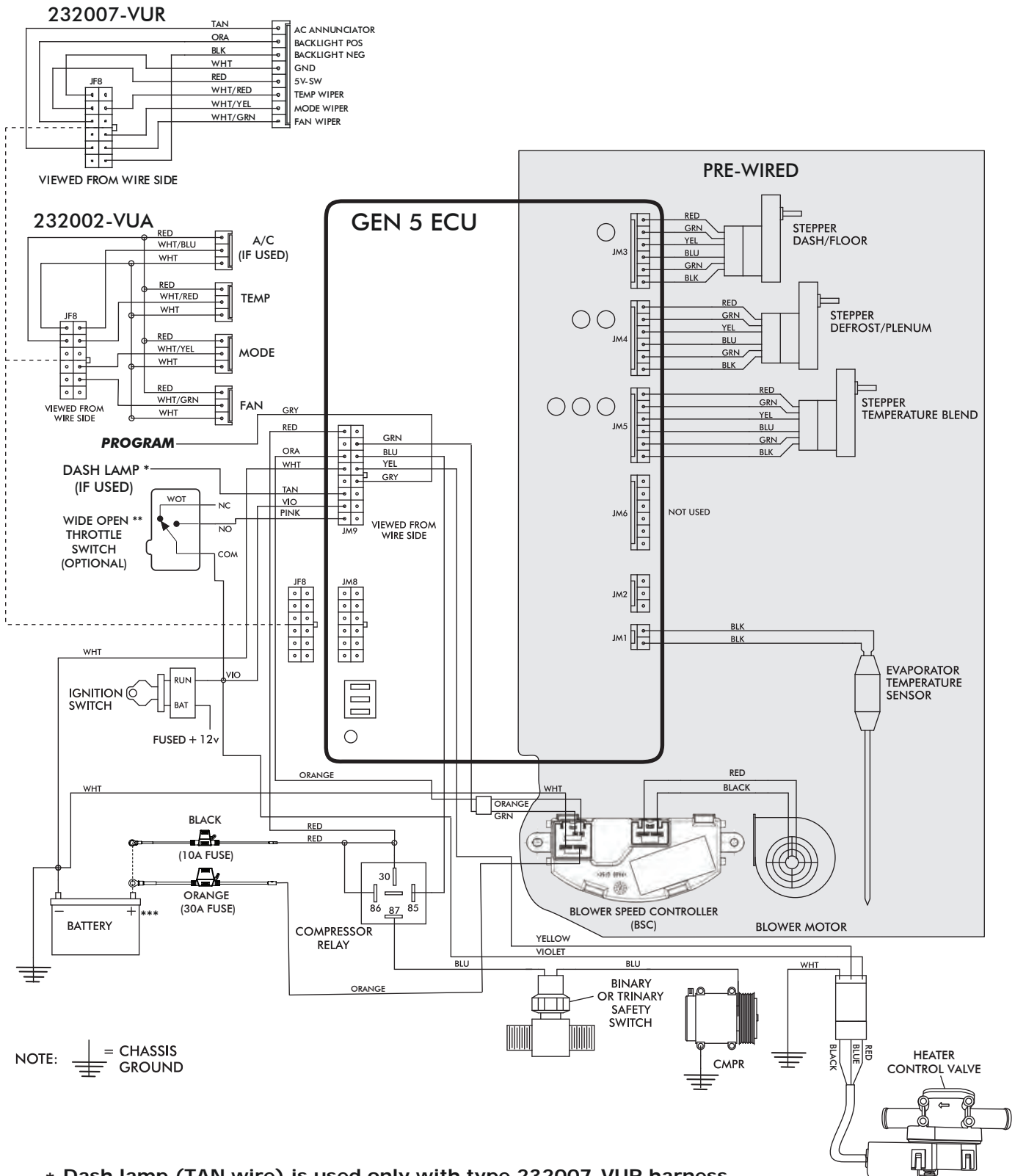

NOTE: = CHASSIS GROUND

* Dash lamp (TAN wire) is used only with type 232007-VUR harness.

** Wide open throttle switch contacts close only at full throttle, which disables A/C compressor.

*** Install fuse assemblies at or as near to the battery as possible.



www.vintageair.com

Gen 5 Wiring Instructions

WIRING HARNESS (231505) ↓

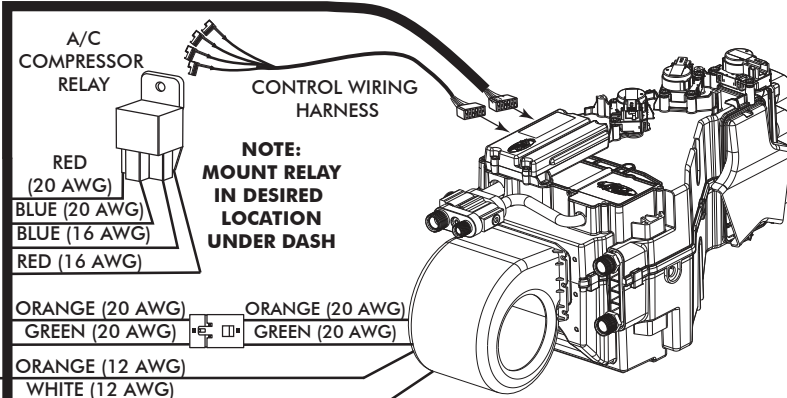

NOTE:
MOUNT RELAY
IN DESIRED
LOCATION
UNDER DASH

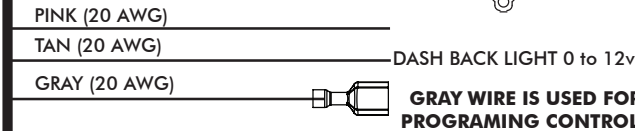
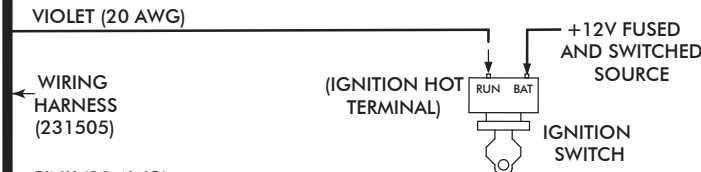
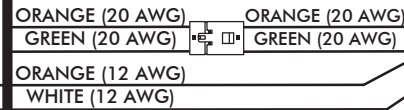

FIREWALL

FIREWALL

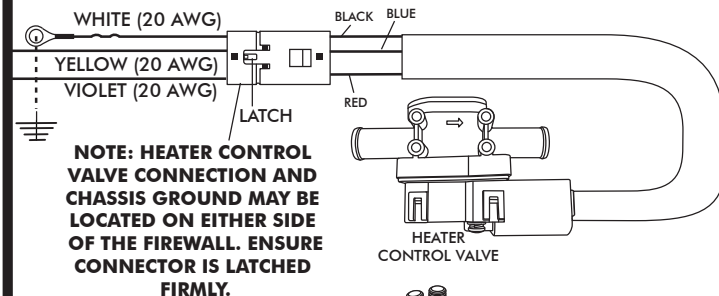

NOTE: HEATER CONTROL VALVE CONNECTION AND CHASSIS GROUND MAY BE LOCATED ON EITHER SIDE OF THE FIREWALL. ENSURE CONNECTOR IS LATCHED FIRMLY.

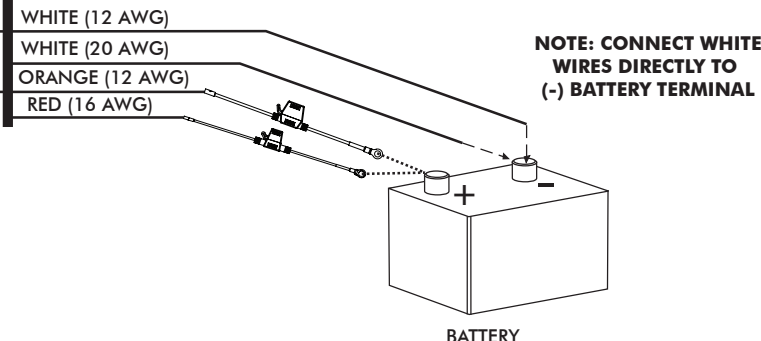
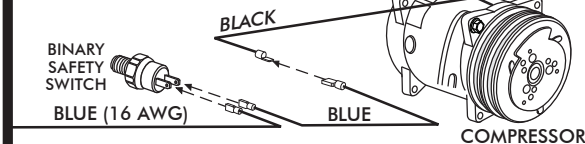

NOTE: CONNECT WHITE WIRES DIRECTLY TO (-) BATTERY TERMINAL

Ignition Switch:

Using provided butt splice (PN 226004), connect the 20 AWG violet wire to a 5A fused and switched 12V source such as Key On.

Wide Open Throttle Switch (Optional):

If a wide open throttle switch is required, connect the 20 AWG pink wire to a normally open switch that, when closed, connects a fused and switched 12V source to the pink wire. See Gen 5 wiring diagram for an example.

Dash Light (Optional):

If using a Vintage Air control panel with back light, connect the 20 AWG tan wire to the vehicle's dash back light 0-12V using provided butt splice (PN 226004).

Heater Control Valve:

Connect the Violet/Yellow/White twisted branch with 3 position connector into the heater control valve connector. Ensure that the mating latch is fully seated.

Binary/Trinary & Compressor:

Binary Switch: Terminate provided insulated female terminal (PN 23172-VUW) to the blue 16 AWG wire. Connect as shown.

Trinary Switch: Connect according to trinary switch wiring diagram.

Battery Connections:

ECU Ground: Terminate provided ring terminal (PN 226110) to 20 AWG white wire from the 231505 wire assembly and install at battery.

ECU PWR: Terminate provided fuse assembly with black leads (PN 233012) to the 20 AWG red wire from the 231505 wire assembly. Install provided 10A Red Mini Fuse (PN 226118). Install at battery.

Blower Speed Controller (BSC) Ground: Terminate provided ring terminal (PN 226111) to 12 AWG white wire from the 232020 wire assembly and install at battery.

Blower Speed Controller (BSC) PWR: Terminate provided fuse assembly with orange leads (PN 233008) to the 12 AWG orange wire from the 232020 wire assembly. Install provided 30A Green ATO/ATC Fuse (PN 226125). Install at battery.



www.vintageair.com

Operation of Controls

On Gen IV or Gen 5 systems with three lever/knob controls, the temperature control toggles between heat and A/C operations. To activate A/C, move the temperature lever/knob all the way to cold and then back it off to the desired vent temperature. For heat operation, move the temperature lever/knob all the way to hot and then adjust to the desired vent temperature. The blower will momentarily change speed, each time you toggle in and out of heat and A/C operations, to indicate the change.

Blower Speed

This lever/knob controls blower speed, from OFF to HI.

Mode Control

This lever/knob controls the mode positions, from DASH to FLOOR to DEFROST, with a blend in between.

Temperature Control

This lever/knob controls the temperature, from HOT to COLD.

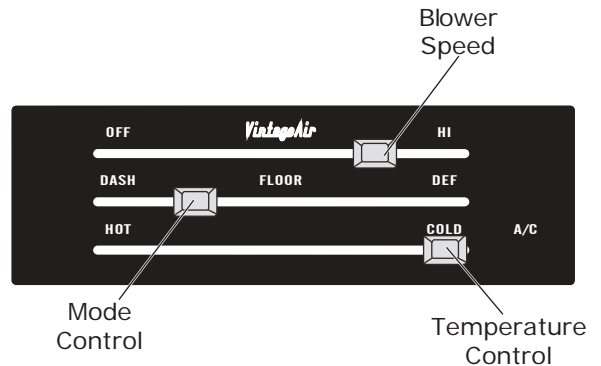

A/C Operation

Blower Speed

Adjust to desired speed.

Mode Control

Adjust to desired mode position (DASH position recommended).

Temperature Control

For A/C operation, adjust to coldest position to engage compressor (adjust between HOT and COLD to reach desired temperature).

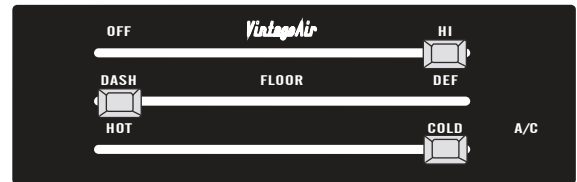

Heat Operation

Blower Speed

Adjust to desired speed.

Mode Control

Adjust to desired mode position (FLOOR position recommended).

Temperature Control

For maximum heating, adjust to hottest position (adjust between HOT and COLD to reach desired temperature).



Defrost/De-fog Operation

Blower Speed

Adjust to desired speed.

Temperature Control

Adjust to desired temperature.

Mode Control

Adjust to DEFROST position for maximum defrost, or between FLOOR and DEFROST positions for a bi-level blend (Compressor is automatically engaged).

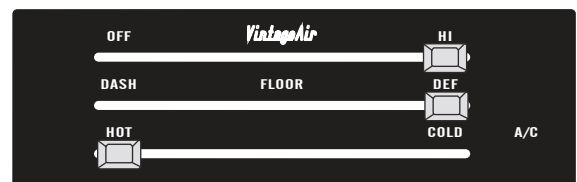



www.vintageair.com

Troubleshooting Guide

This printed troubleshooting guide is our basic guide that covers common installation problems. To see our advanced diagnostics and troubleshooting guide, please refer to the following page for instructions on how to download the complete guide.

WARNING: While troubleshooting the system, never probe connector terminals from the front mating side, only back probe.

WARNING: While troubleshooting the system, never use automotive check lights.

Symptom	Condition	Checks	Actions	Notes
1. Blower stays on high speed with ignition on.	No other functions work.	Check for damaged pins or wires in the control panel wire assembly and mating header at ECU.	If found damaged, replace wire assembly or ECU.	If fuse continues to blow, there is a serious problem in the wiring. Check all wiring and ensure the wire is not damaged and shorting out along its route.
	All other functions work.	Check for a bad ECU GND. Check for damaged pins or wires in the control panel wire assembly and mating header at ECU. Check if Blower power fuse is blown. Check for a bad ECU GND.	If found damaged, replace wire assembly or ECU. Replace fuse. Repair connection.	
2. Compressor will not turn on (All other functions work).	System is not charged.	System must be charged for compressor to engage.	Charge system.	Danger: Never bypass safety switch with engine running. Serious injury can result.
	System is charged.	Check for faulty A/C potentiometer or associated wiring (not applicable to 3-pot controls). Check for disconnected or faulty thermistor.	Check continuity to ground on white control head wire. Check for 5V on red control head wire. Check 2-pin connector at ECU housing.	To check for proper pot function, check voltage at white/red wire. Voltage should be between 0V and 5V, and will vary with pot lever position. Disconnected or faulty thermistor will cause compressor to be disabled.
	Compressor will not turn off (All other functions work).	Check for faulty A/C potentiometer or associated wiring.	Repair or replace pot/control wiring.	Red wire at A/C pot should have approximately 5V with ignition on. White wire will have continuity to chassis ground. White/Red wire should vary between 0V and 5V when lever is moved up or down.
3. Compressor will not turn off (All other functions work).	System is charged.	Check for faulty A/C relay.	Replace relay.	



www.vintageair.com

Troubleshooting Guide (Cont.)

Symptom	Condition	Checks	Actions	Notes
4. System will not turn on, or runs intermittently.	Works when engine is not running; shuts off when engine is started	Noise interference from either ignition or alternator.	Install capacitors on ignition coil and alternator. Ensure good ground at all points. Relocate coil and associated wiring away from ECU and ECU wiring. Check for burned or loose plug wires.	Ignition noise (radiated or conducted) will cause the system to shut down due to high voltage spikes. If this is suspected, check with a quality oscilloscope. Spikes greater than 16V will shut down the ECU. Install a radio capacitor at the positive post of the ignition coil (see radio capacitor installation bulletin). A faulty alternator or worn out battery can also result in this condition.
	Will not turn on under any conditions.	Verify connections on power lead, ignition lead, and both white ground wires. Verify battery voltage is greater than 10 volts and less than 16 while engine is running.	Check for power at ECU, and confirm ignition is being applied to ECU properly. Verify proper meter function by checking the condition of a known good battery.	
5. Loss of mode door function.	No mode change at all.	Check for damaged mode switch or potentiometer and associated wiring.		
	Blower turns on and off rapidly.	Battery voltage is at least 12V. Battery voltage is less than 12V.	Ensure all system grounds and power connections are clean and tight. Charge battery.	System shuts off blower at 10V. Poor connections or weak battery can cause shutdown at up to 11V.
7. Erratic functions of blower, mode, temp, etc.		Check for damaged switch or pot and associated wiring.	Repair or replace.	

Advanced Diagnostics and Troubleshooting Guide

If after referencing the Troubleshooting Guide, the issue is not resolved, move to The Advanced Diagnostics and Troubleshooting Guide that covers the following:

- **ECU Diagnostics Codes**
 1. **ECU Blink Sequence**
 2. **Firmware Version Number**
 3. **ECU Model Number**
 4. **ECU Start-Up Blink Sequence**
 5. **Diagnostic Codes**
- **Complete Advanced Troubleshooting Guidelines**

Access the latest version of the Advanced Diagnostics and Troubleshooting Guide by scanning the following QR code on your mobile device:



You can also access the guide by typing the following address into your web browser:

https://www.vintageair.com/instructions_pdf/905000.pdf



www.vintageair.com

Packing List: Evaporator Kit (564332)

No.	Qty.	Part No.	Description
1.	1	765100	Gen 5 Magnum Module _____
2.	1	784332	Accessory Kit _____

** Before beginning installation, open all packages and check contents of shipment. Please report any shortages directly to Vintage Air within 15 days. After 15 days, Vintage Air will not be responsible for missing or damaged items.

1



Gen 5 Magnum
Module
765100

Checked By: _____
Packed By: _____
Date: _____

Packing List: Evaporator Kit (564333)

No.	Qty.	Part No.	Description
1.	1	765200	Gen 5 Super Magnum Module _____
2.	1	784332	Accessory Kit _____

** Before beginning installation, open all packages and check contents of shipment. Please report any shortages directly to Vintage Air within 15 days. After 15 days, Vintage Air will not be responsible for missing or damaged items.

1



Gen 5 Super
Magnum Module
765200

Checked By: _____
Packed By: _____
Date: _____

2

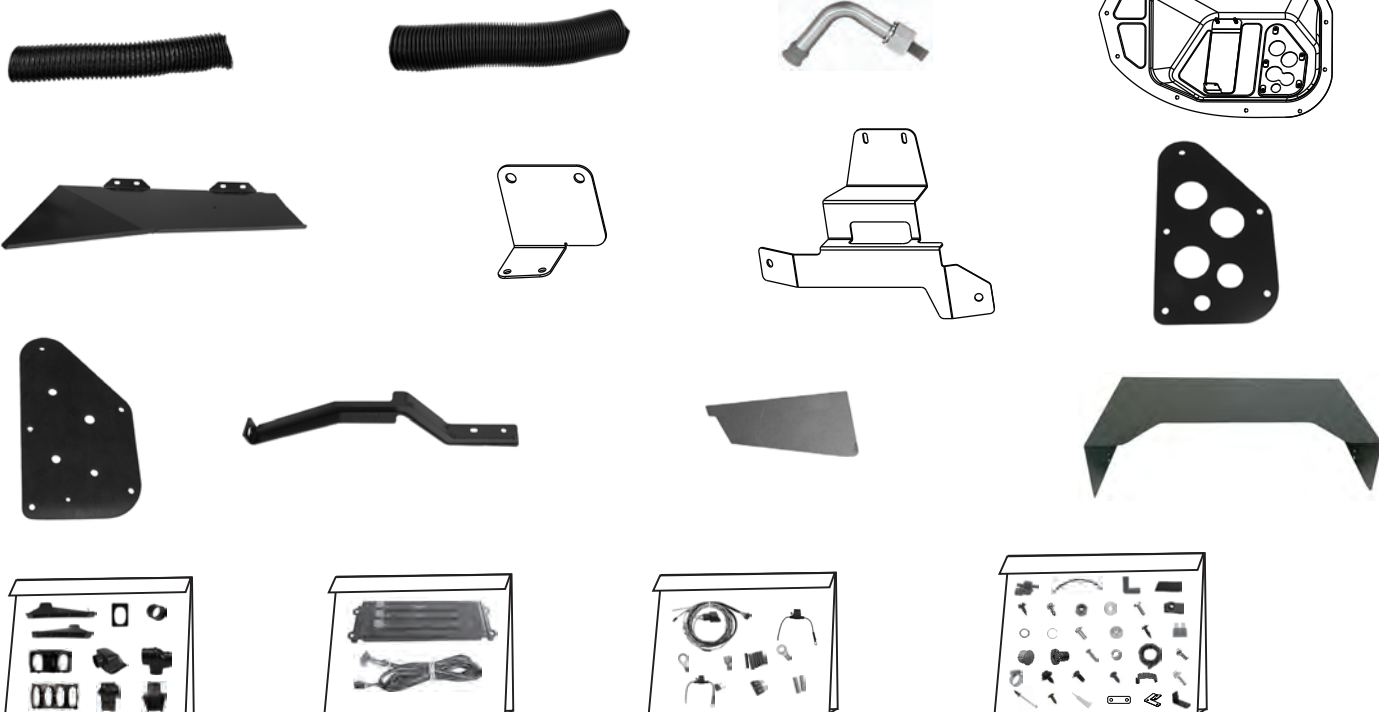

Accessory Kit
784332

NOTE: Images may not depict actual parts and quantities.
Refer to packing list for actual parts and quantities.