

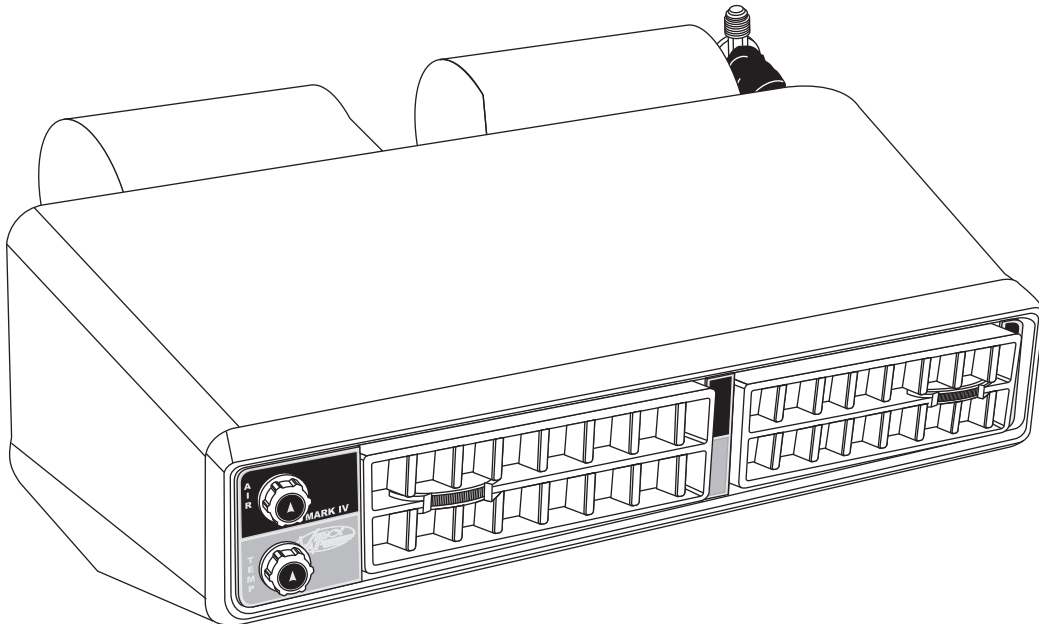

an ISO 9001:2015 Registered Company

Mark IV (672001-VHY)



18865 Goll St. San Antonio, TX 78266
Phone: 800-862-6658
Sales: sales@vintageair.com
Tech Support: tech@vintageair.com
www.vintageair.com



www.vintageair.com

Table of Contents

Cover.....	1
Table of Contents.....	2
Packing List/Parts Disclaimer.....	3
Information Page.....	4
Planning Overview.....	5
Mark IV Installation.....	6
Drain Hose Assembly, Wiring.....	7
A/C Hose Installation, Lubricating O-rings.....	8
Final Steps, Hose Routing Diagram.....	9
Operation of Controls, A/C Thermostat Explained.....	10
Packing List.....	11



www.vintageair.com

Packing List: Mark IV (672001-VHY)

No.	Qty.	Part No.	Description
1.	1	672000-VHY	Mark IV Under Dash Unit (Drain Kit and Bracket Kit Included with Evaporator)

**** Before beginning installation, open all packages and check contents of shipment. Please report any shortages directly to Vintage Air within 15 days. After 15 days, Vintage Air will not be responsible for missing or damaged items.**

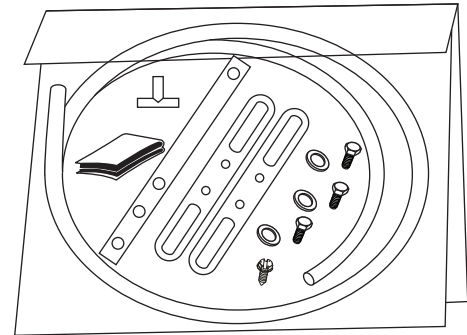
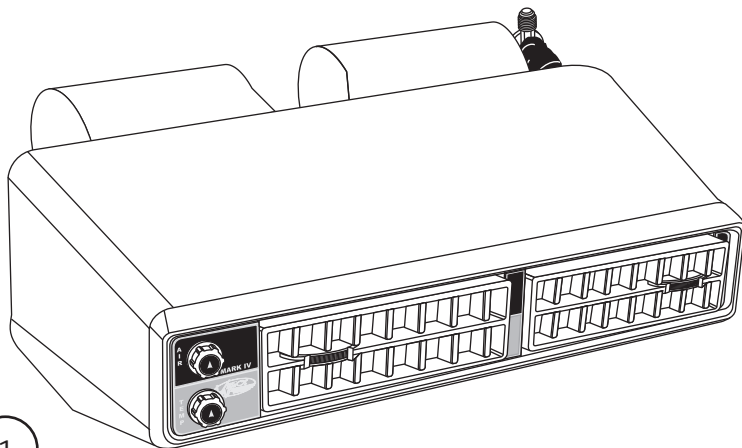

NOTE: Images may not depict actual parts and quantities. Refer to packing list for actual parts and quantities.



www.vintageair.com

Important Notice—Please Read

For Maximum System Performance, Vintage Air Recommends the Following:

NOTE: Vintage Air systems are designed to operate with R134a refrigerant only. Use of any other refrigerant could damage your A/C system and/or vehicle, and possibly cause a fire, in addition to potentially voiding the warranties of the A/C system and its components.

Refrigerant Capacities:

Vintage Air System: 1.8 lbs. (1 lb., 12 oz.) of **R134a**, charged by weight with a quality charging station or scale. **NOTE:** Use of the proper type and amount of refrigerant is critical to system operation and performance.

Other Systems: Consult manufacturer's guidelines.

Lubricant Capacities:

New Vintage Air-supplied Sanden Compressor: No additional oil needed (Compressor is shipped with proper oil charge).

All Other Compressors: Consult manufacturer (Some compressors are shipped dry and will need oil added).

Safety Switches

Your Vintage Air system is equipped with a binary pressure safety switch. A binary switch disengages the compressor clutch in cases of extreme low pressure conditions (Refrigerant Loss) or excessively high head pressure (406 PSI) to prevent compressor damage or hose rupture. A trinary switch combines Hi/Lo pressure protection with an electric fan operation signal at 254 PSI, and should be substituted for use with electric fans. Compressor safety switches are extremely important since an A/C system relies on refrigerant to circulate lubricant.

Service Info:

Protect Your Investment: Prior to assembly, it is critical that the compressor, evaporator, A/C hoses and fittings, hardlines, condenser and receiver/drier remained capped. Removing caps prior to assembly will allow moisture, insects and debris into the components, possibly leading to reduced performance and/or premature failure of your A/C system. This is especially important with the receiver/drier.

Additionally, when caps are removed for assembly, **BE CAREFUL!** Some components are shipped under pressure with dry nitrogen.

Evacuate the System for 35-45 Minutes: Ensure that system components (Drier, compressor, evaporator and condenser) are at a temperature of at least 85° F. On a cool day, the components can be heated with a heat gun *or* by running the engine with the heater on before evacuating. Leak check and charge to specifications.

Bolts Passing Through Cowl and/or Firewall:

To ensure a watertight seal between the passenger compartment and the vehicle exterior, for all bolts passing through the cowl and/or firewall, Vintage Air recommends coating the threads with silicone prior to installation.



www.vintageair.com

Planning Overview

NOTE: Before starting the installation, check the function of the vehicle (horn, lights, etc.) for proper operation, and study the instructions, illustrations, & diagrams.

For performance, aesthetics, and ease of installation, Vintage Air recommends planning the air conditioning installation as early as possible during the development phase of your project. There are many factors that go into making each air conditioning installation different, including:

1. Type of vehicle/engine and location of engine.
2. Type of air conditioning equipment used.
3. Owner's preferences.

The mounting location of the evaporator unit is determined in part by the space available for the hose routing. The components used in the hose routing process (bulkhead plates, fittings and grommets, etc.) will also influence the location of the evaporator unit. When planning the hose routing, install the major components first. Mount the compressor, condenser and drier, and then temporarily position the evaporator under the dash. For proper condensate drainage, it is very important to level the evaporator both left-right and fore-aft. Place a bubble level on the bottom of the case as shown in the drain hose section on Page 7 to confirm. Left-right should be as level as possible. Fore-aft may have up to 2 degrees tilt toward the drain outlets (louvers up). Final mounting of the evaporator should not be done until you have verified that all hoses attaching to the evaporator will exit the firewall and/or kick panel as planned. Before cutting them to length, the hoses must be routed exactly the way they will be when finished.

The Mark IV unit was designed for street rods, custom cars and trucks. The evaporator unit mounts under the dash.

Read the installation instructions completely and familiarize yourself with all of the parts and illustrations.

The installation of this unit varies, depending upon to the body manufacturer or modifications to the original body. Take your time and double check before drilling or cutting.

Check for, and fill in any holes in the firewall and floor. Insulate and seal the firewall, floor, door panels and headliner to reduce the amount of heat entering the car. Figure 1, below, shows the general location of the evaporator. Actual mounting locations will vary.

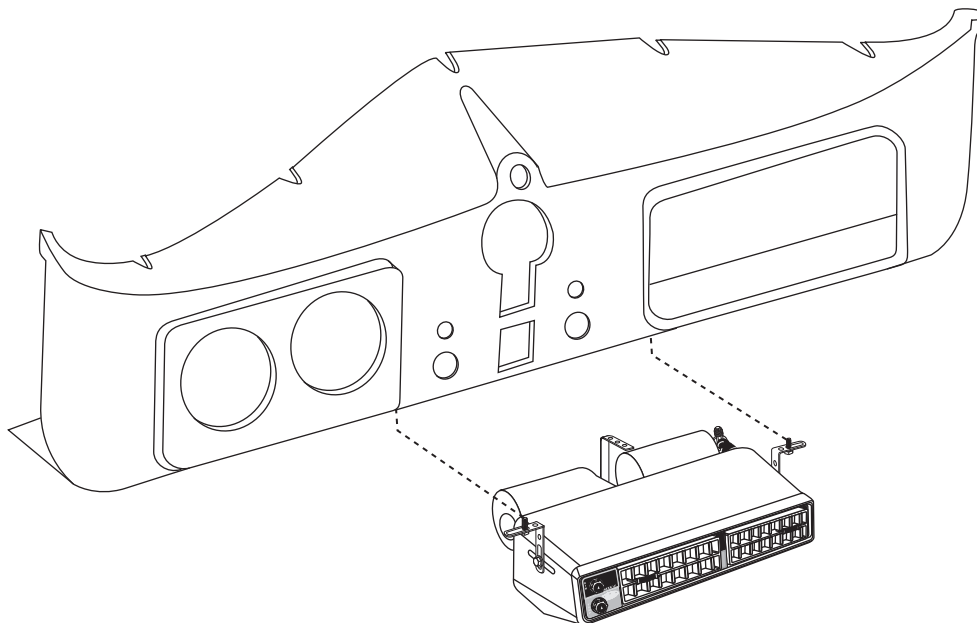

Figure 1



www.vintageair.com

Mark IV Installation

1. Using the illustrations below as a guide, install the left, right, and rear mounting brackets onto the unit.
NOTE: The mounting brackets may be cut or bent as needed or desired.

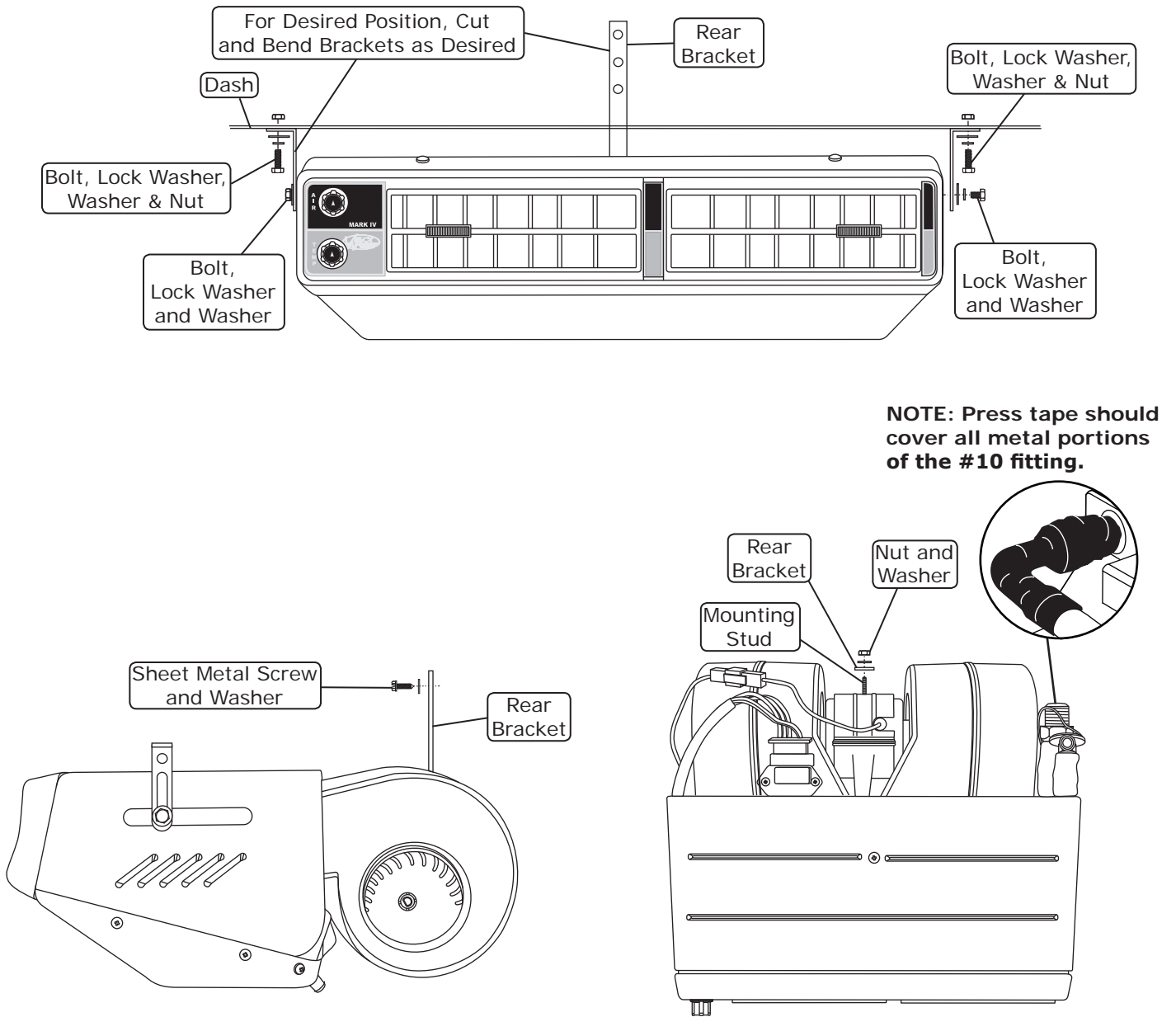

Figure 2



www.vintageair.com

Drain Hose Assembly

1. Locate the (2) drain nipples at the bottom of the unit. Using the illustrations in Figure 3, below, as a guide, assemble the drain hose and drain tee, and attach the drain hose assembly to the nipples on the unit. **NOTE: When determining drain location, consider the following: Drain hose must be installed with a minimum 1" drop from the drain nipples on the bottom of the evaporator case to the point where the drain hose exits the vehicle. Also, be sure to route drain hose such that water drips directly onto the ground, rather than on any part of the vehicle frame. The drain hose and tee can be assembled in any configuration that meets these requirements.**

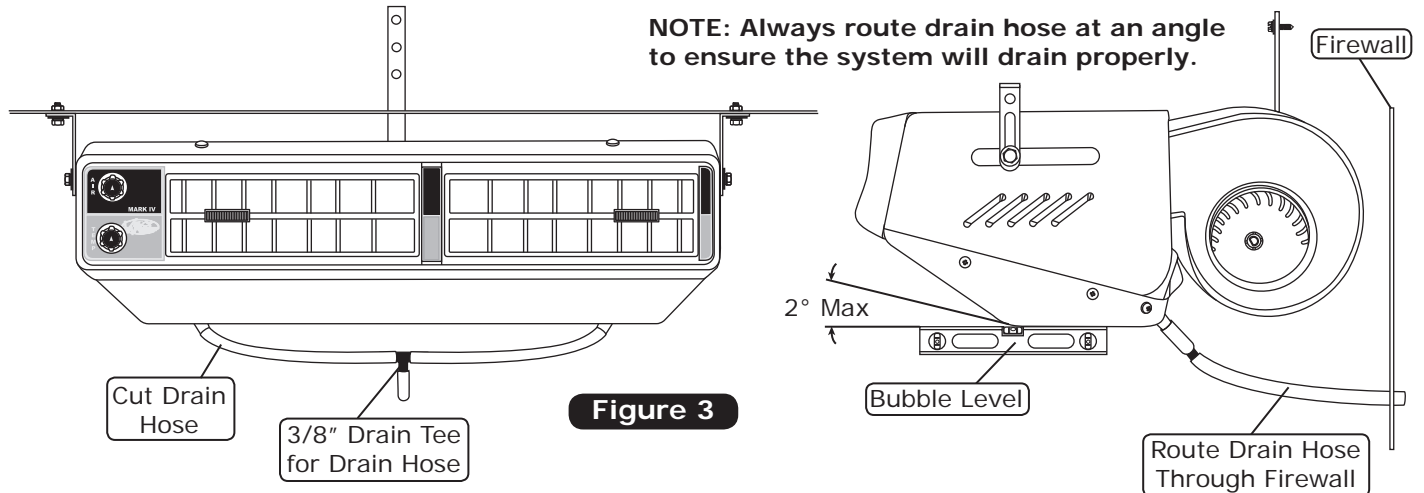

NOTE: Use a bubble level to ensure that the unit is level, both left-right and fore-aft. Left-right should be as level as possible. Fore-aft may have up to 2 degrees tilt toward the drain outlets (louvers up). Improper Leveling may result in water dripping from the unit.

Wiring

1. Use the illustration below as a guide for routing the system wires.

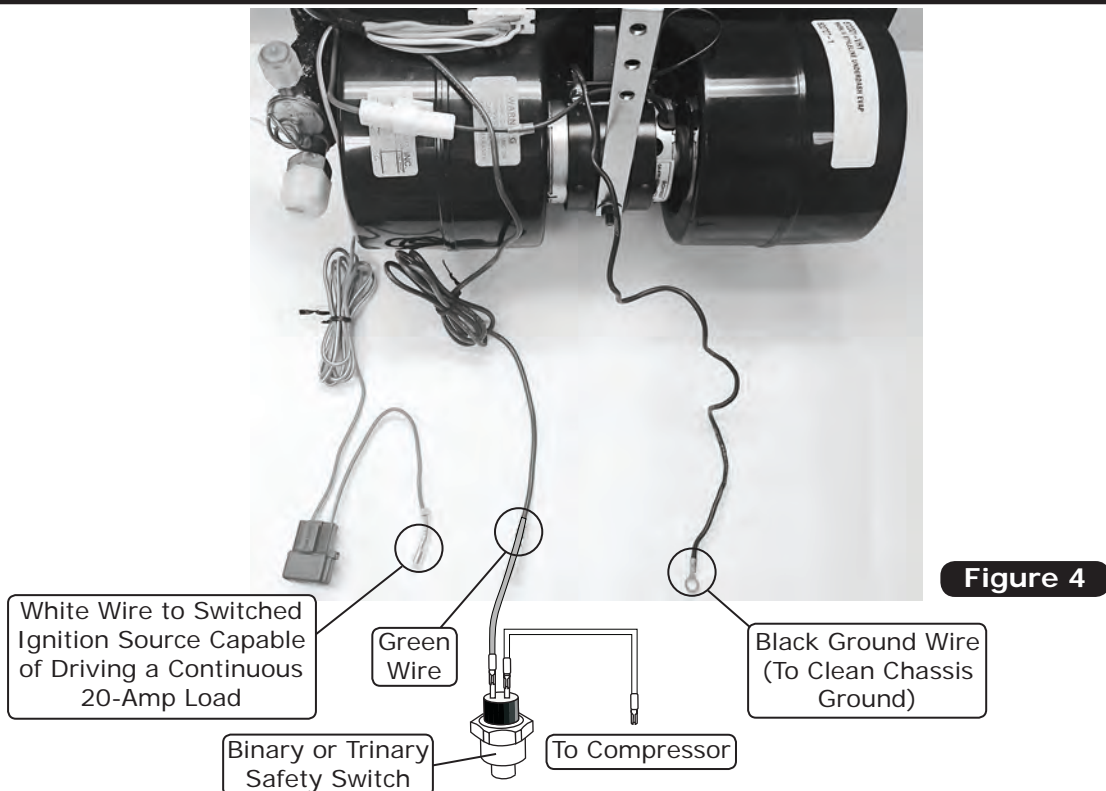



www.vintageair.com

A/C Hose Installation

NOTE: Hose routing instructions below assume use of typical hose kit, which must be purchased separately.

1. Push the 5/16" ID hose onto a #6 fitting (See hose routing illustration on Page 9). Install the fitting onto the expansion valve (finger tight). Push the 1/2" ID hose onto a #10 fitting, and install the fitting onto the #10 line on the evaporator (See hose routing illustration on Page 9).
2. At this time, try to determine where you want your lines to go through the firewall. Move the hoses to that point. Hold the fittings up to their respective hoses and determine if the hoses will conform to the location for the bulkhead fittings or optional bulkhead plate (Vintage Air part #34215-VUQ). The 1/2" hose is hard to bend at a sharp angle, and the fittings take up a certain amount of space. Before you drill holes in your firewall, make sure you can make the hoses fit in your desired location. The engine compartment appearance is a consideration when choosing this location.
3. When you have decided where you want to place your bulkhead fittings, mark these points with a grease pencil and make a template from the inside, locating where the holes will be cut. With this template, locate the same points on the outside of the firewall. Mark these points with a grease pencil.
4. Determine the best location for the drier that will allow adequate room for the hose and fittings that connect the drier to the bulkhead fitting.
5. Mount the drier (Keep the drier capped as much as possible. If you must screw the fitting to the drier, tape it closed). **NOTE: The drier is usually mounted where you have room for it. Just remember to mount it in the coolest spot possible, and vertically so the sight glass is directly on top (Not next to the exhaust manifold). It can be mounted inside the vehicle as well.**
6. At this point, cut holes for the bulkhead fittings and install them.
7. Using the hose routing illustration as a guide, route the remaining A/C lines and cut them to length.
8. At this time, you should have the refrigeration hoses cut to their proper length. Pay close attention to the orientation of any hose with two angled fittings. Any hose with two angled fittings must be marked from the hose to the fittings to assure they will remain in this position after crimping. The rubber hose is only capable of a minimal amount of twist to aid alignment.
9. Remove the hoses and crimp the ends. If you do not have access to the proper equipment, take them to a qualified A/C service center for crimping (See crimping instructions supplied with the hose kit).
10. With the evaporator trial fit complete, remove the unit and lower it into the vehicle.
11. After crimping the hoses, locate the #6 evaporator A/C hose. Lubricate a #6 A/C O-ring (See Figure 3, below) and the threads on the fitting, and install it on the expansion valve. Tighten carefully.
12. Locate the #10 evaporator A/C hose. Lubricate a #10 O-ring and the threads on the fitting, and install it on the #10 line of the evaporator. Tighten carefully.
13. Wrap the #10 fitting with press tape, and cover all exposed metal surfaces (Do not wrap the #6 hose fitting) (See Figure 2, Page 6).

Lubricating O-rings

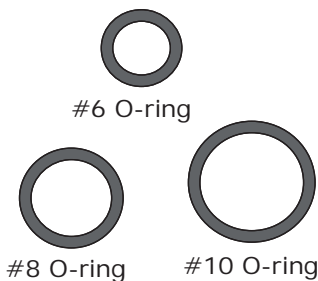

NOTE: Standard torque specifications:
 #6: 11 to 13 ft.-lb.
 #8: 15 to 20 ft.-lb.
 #10: 21 to 27 ft.-lb.

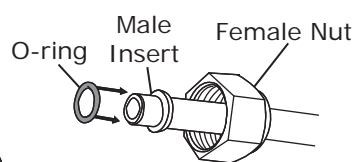

For a proper seal of fittings: Install supplied O-rings as shown, and lubricate with supplied oil.

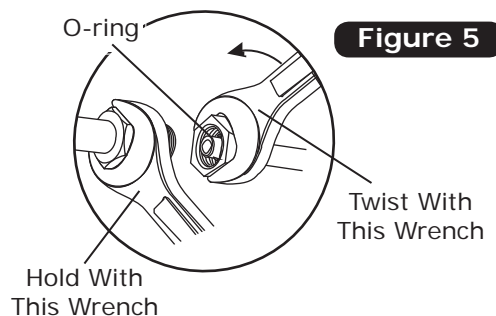
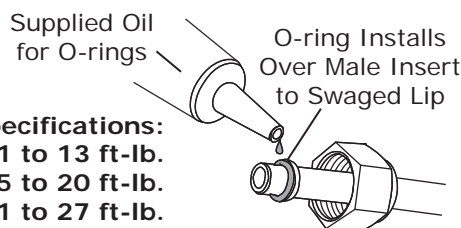

Figure 5



www.vintageair.com

Final Steps

1. Double check all fittings, brackets and belts for tightness.
2. Vintage Air recommends that all A/C systems be serviced by a licensed automotive A/C technician.
3. Evacuate the system for a minimum of 45 minutes prior to charging, and perform a leak check prior to servicing.
4. Charge the system to the capacities stated on Page 4 of this instruction manual.

Hose Routing Diagram

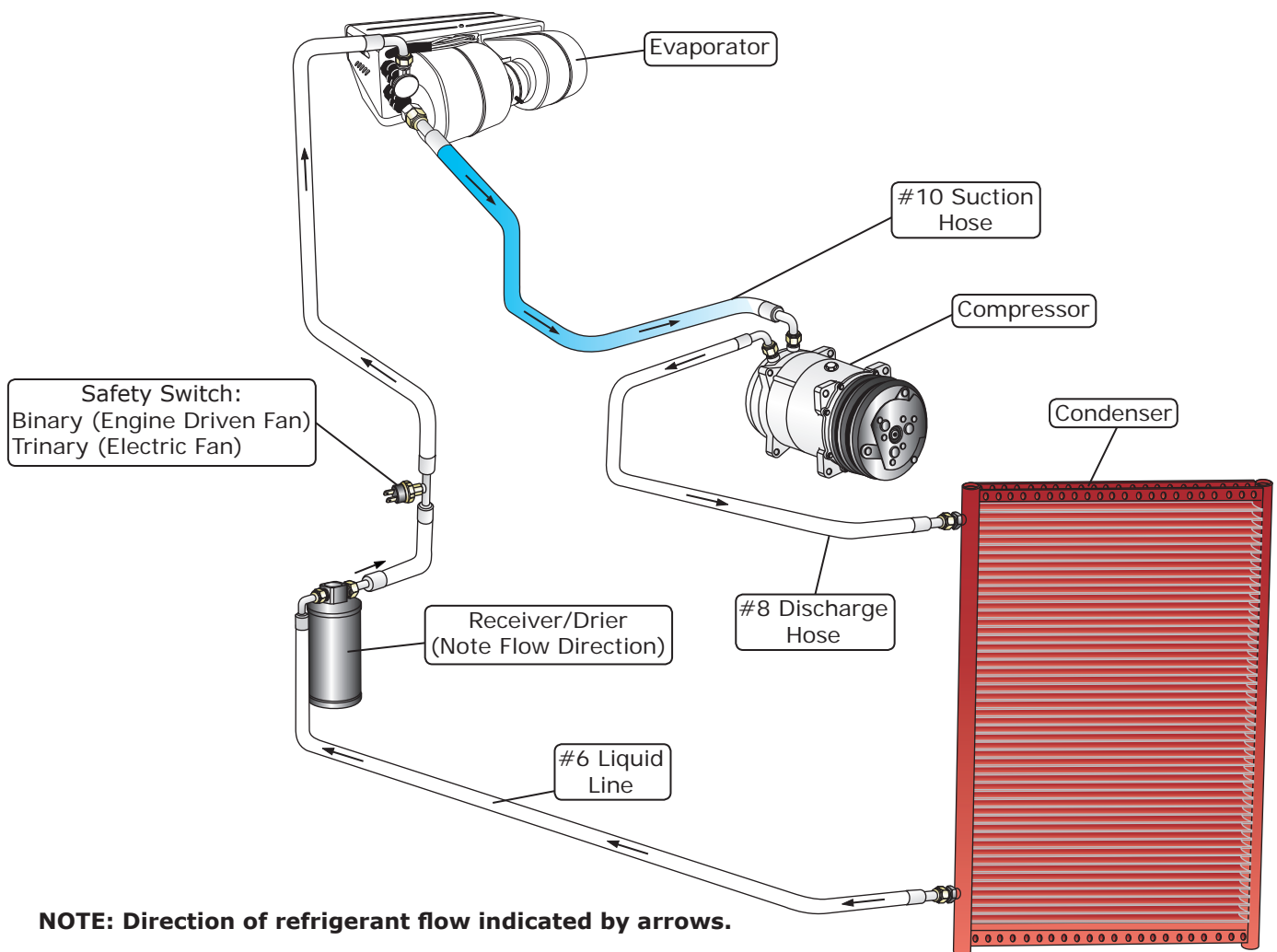

NOTE: Direction of refrigerant flow indicated by arrows.

Figure 6



www.vintageair.com

Operation of Controls

The Mark IV A/C system employs a 3-speed blower and a mechanical thermostat to control airflow and temperature.

For maximum performance and comfort, Vintage Air recommends always running the evaporator as cold as possible by positioning the "TEMP" knob with the arrow pointing straight up, and adjusting the fan speed to the desired level of comfort. For maximum cooling, position the "AIR" knob fully clockwise and the "TEMP" knob with the arrow pointing straight up. If the vent temperature is uncomfortably cold, the output temperature can be increased by rotating the "TEMP" knob counterclockwise. To turn the system off, rotate the "AIR" knob full counterclockwise.

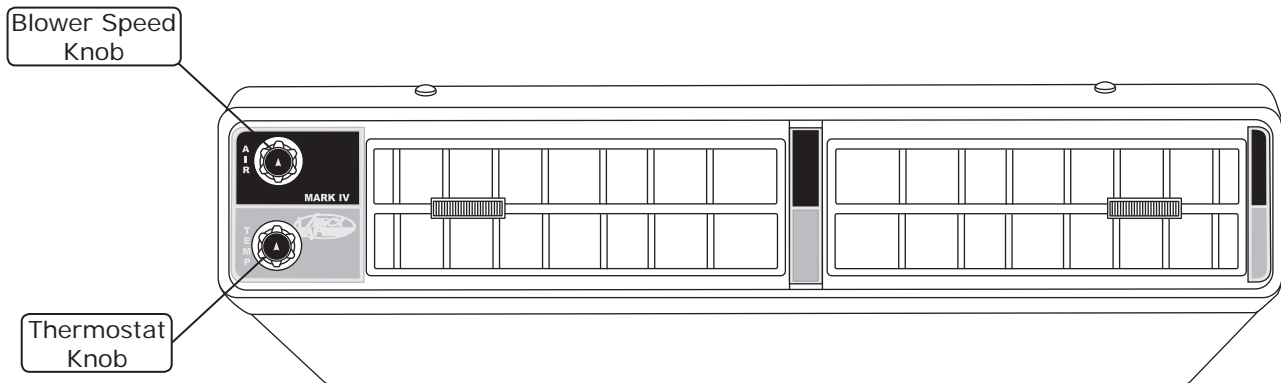

Figure 7

A/C Thermostat Explained

The lower knob on the Mark IV system controls a mechanical A/C thermostat. This thermostat operates differently than that of a home air conditioning thermostat. An automotive thermostat controls the temperature of the evaporator coil rather than the temperature of the air. Its main purpose is to prevent ice from forming between the fins of the coil, as ice blocks airflow and limits A/C performance. The thermostat employs a gas-filled "capillary tube" probe, which is inserted into the coldest part of the coil, and will cycle the compressor on and off in response to the temperature sensed by the probe. By adjusting the "TEMP" knob to a position with the arrow pointing straight up, the thermostat will turn the compressor off at approximately 34°F at the sensing location. As a result, no ice will be allowed to form on the coil. Sometimes, in areas of very low humidity, it is possible to adjust the thermostat colder without ice forming. Adjusting the thermostat knob to a full clockwise position will turn off the compressor at approximately 28°F. If symptoms of evaporator icing develop, such as reduced airflow with elevated vent temperature, reduce the thermostat setting by rotating the "TEMP" knob counterclockwise. This will allow the evaporator to thaw.



www.vintageair.com

Packing List: Mark IV (672001-VHY)

No.	Qty.	Part No.	Description
1.	1	672000-VHY	Mark IV Under Dash Unit (Drain Kit and Bracket Kit Included with Evaporator)

Checked By: _____
 Packed By: _____
 Date: _____

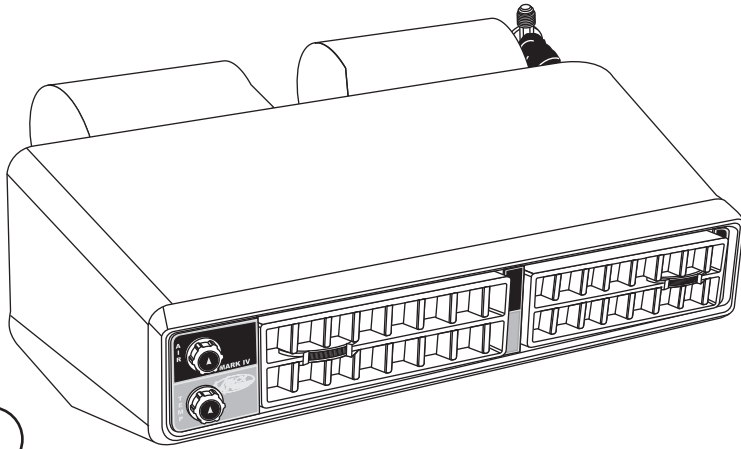

1

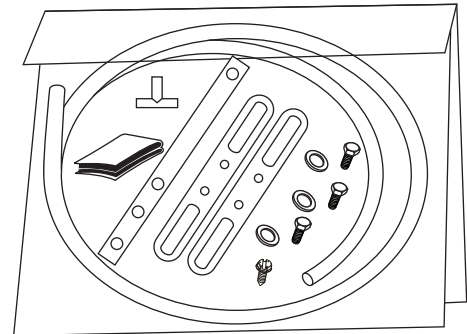

**NOTE: Images may not depict actual parts and quantities.
 Refer to packing list for actual parts and quantities.**