

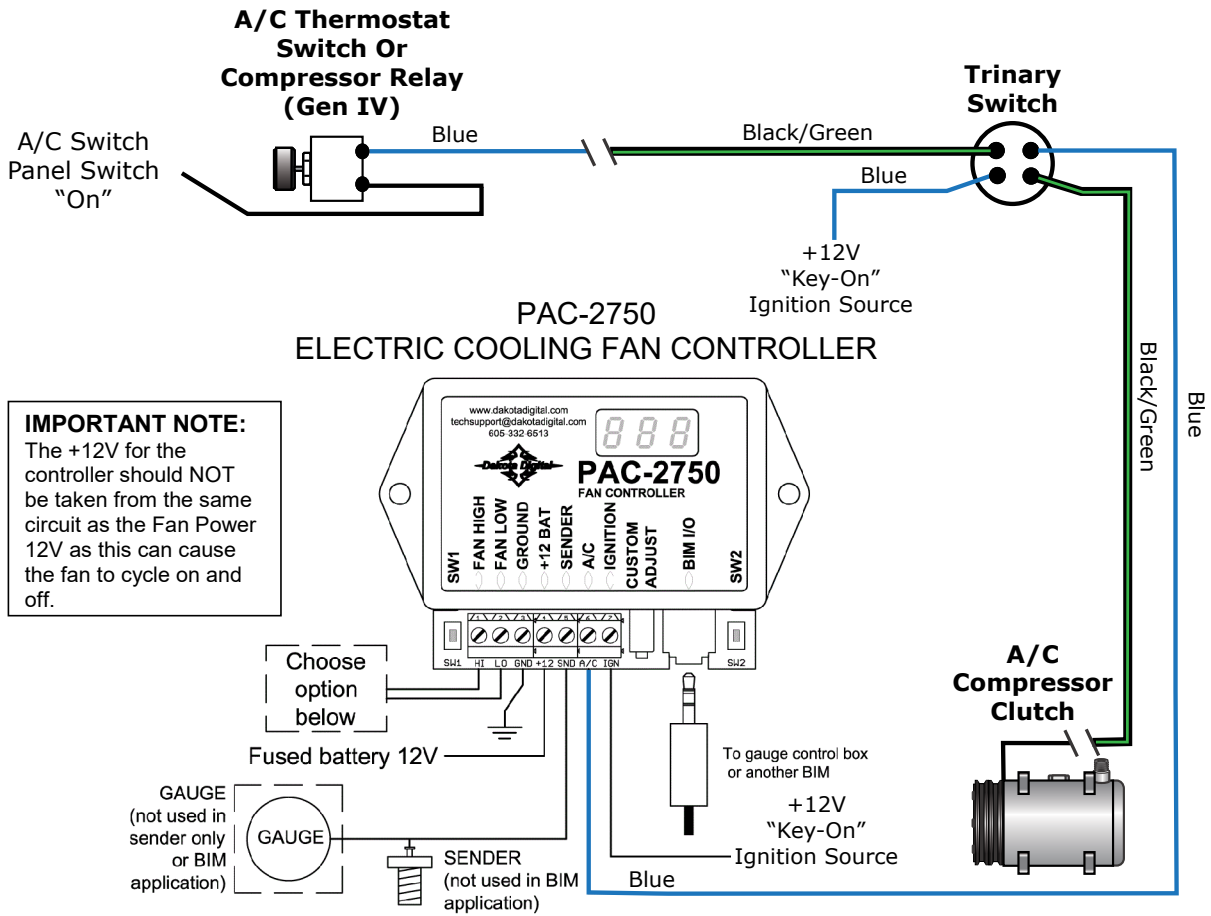

www.vintageair.com

Trinary Switch Wiring Diagram: Dakota Digital PAC 2750



IMPORTANT NOTE:
The +12V for the controller should NOT be taken from the same circuit as the Fan Power 12V as this can cause the fan to cycle on and off.

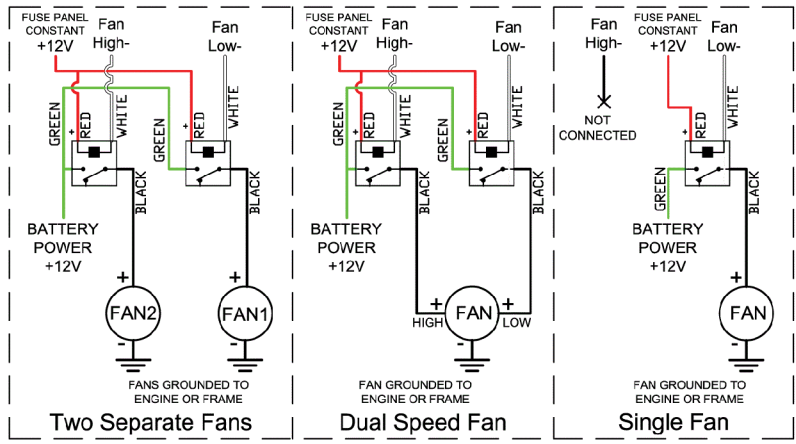

- Required components for installation:**
The PAC-2750 is shipped with necessary components for use with a single fan on a gauged system. These parts include:
- 1 PAC-2750 module
 - 1 RLY-3 relay with wiring harness
 - 1 BIM data cable
 - 1 BIM-xx-2 adapter harnesses
 - 1 Instruction manual

For some options of the PAC-2750, additional components are required. These are listed below.

- Second RLY-3 assembly (needed for dual fan or two speed fan operation)
- 300°F sender Dakota Digital temp sender (for operation without a gauge)

MAN# 650411:D