

VINTAGE AIR

54065-VCU (-A)

• 10305 I.H. 35 N. • SAN ANTONIO • TEXAS 78233 • PH 210-654-7171

INSTALLATION INSTRUCTIONS FOR '64-'65 CHEVELLE

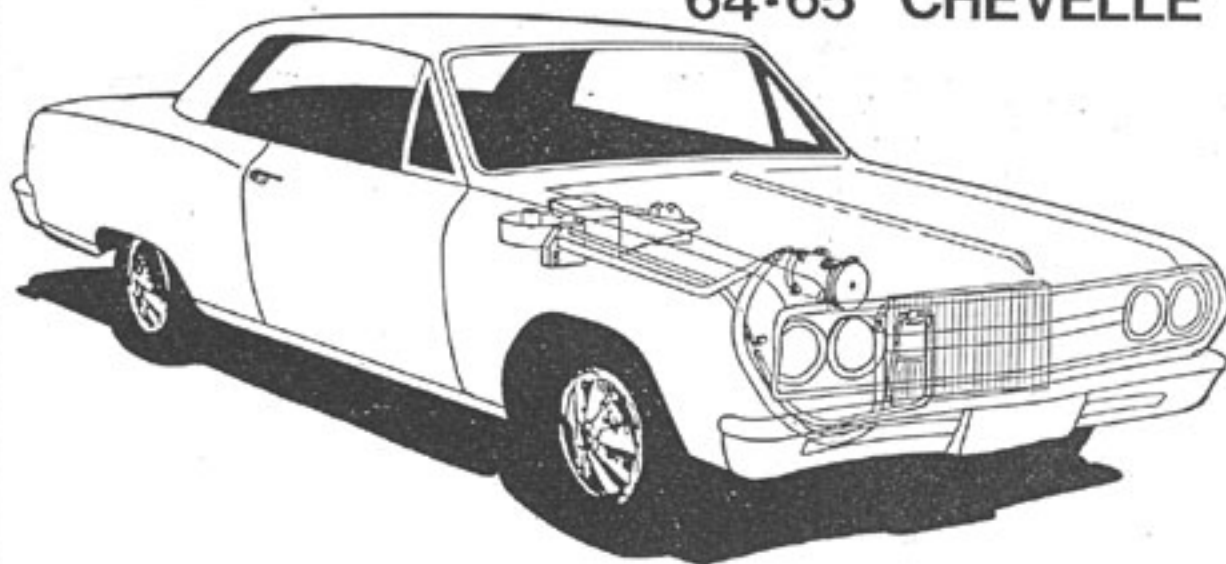

4-13-94

For maximum system performance Vintage Air recommends the following:

1. 18" Heavy-Duty Fan (V.A.PN:32618-VUF) or OEM style clutch fan
2. Fan Shroud
3. Auxillary Cooling Fan Package (V.A.PN:32006-VUF)

REFRIGERATION CAPACITIES:	R-134a	1.8 lbs.
	R-12	2.0 lbs.

LUBRICANT CAPACITIES:	NEW COMPRESSOR - NO ADDITIONAL OIL NEEDED
	USED COMPRESSOR - CONSULT VINTAGE AIR

BEFORE STARTING INSTALLATION, CHECK THE FUNCTION OF THE VEHICLE (HORN, LIGHTS, ETC.) FOR PROPER OPERATION. STUDY THE INSTRUCTIONS, ILLUSTRATIONS, AND DIAGRAMS. DISCONNECT BATTERY.

REMOVE THE FOLLOWING (FIGURE 1)

1. GLOVE BOX DOOR
2. GLOVE BOX (DISCARD)
3. OEM HEATER UNIT (DISCARD)
4. OEM FIREWALL COVER (DISCARD)
5. OEM CABLE CONTROLS

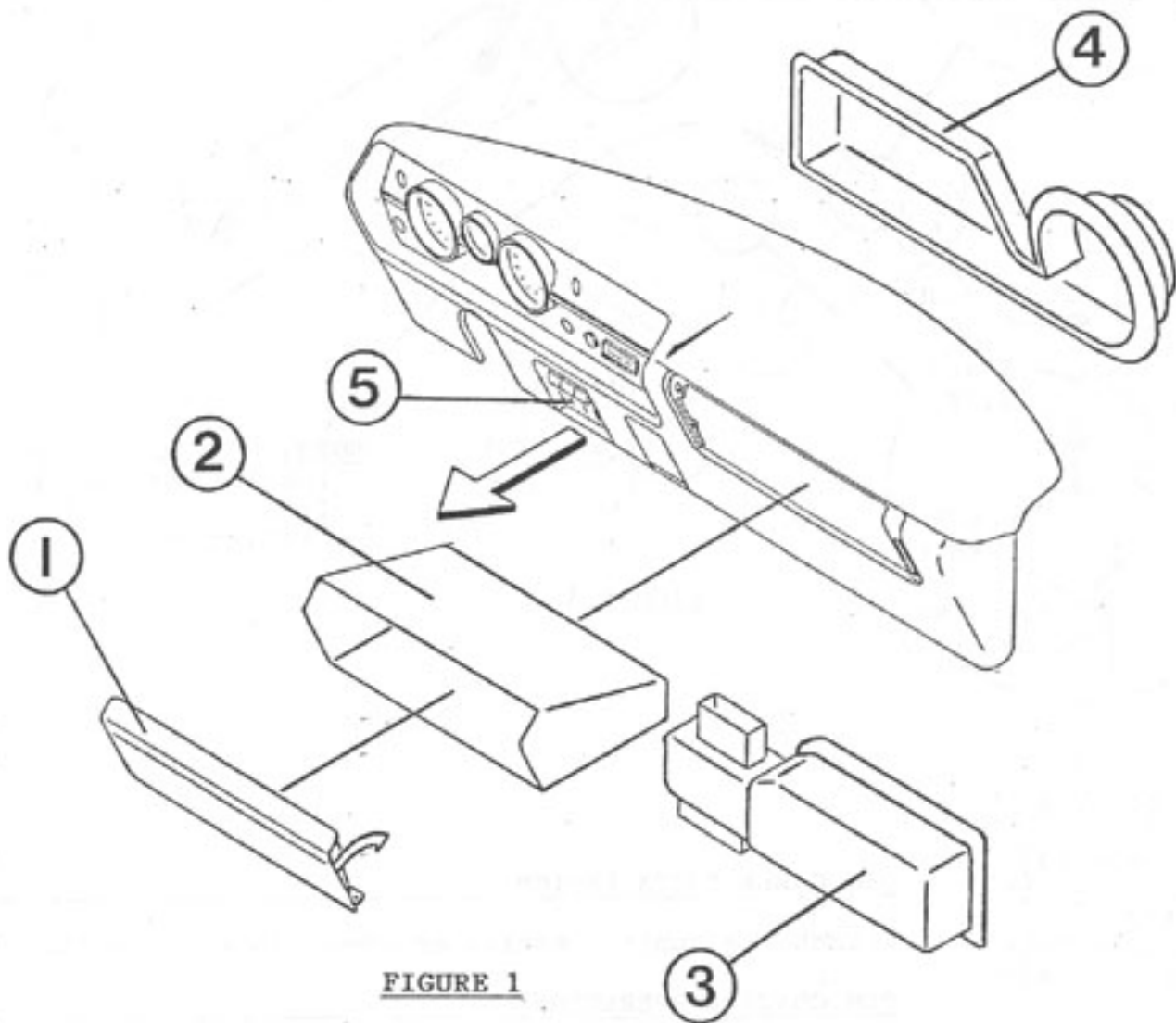
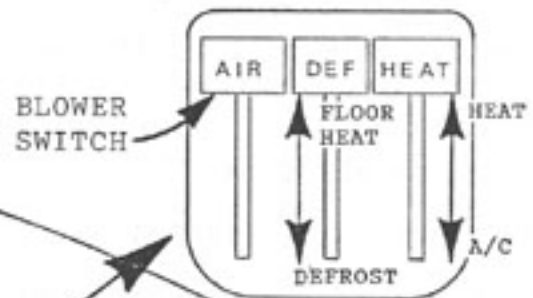
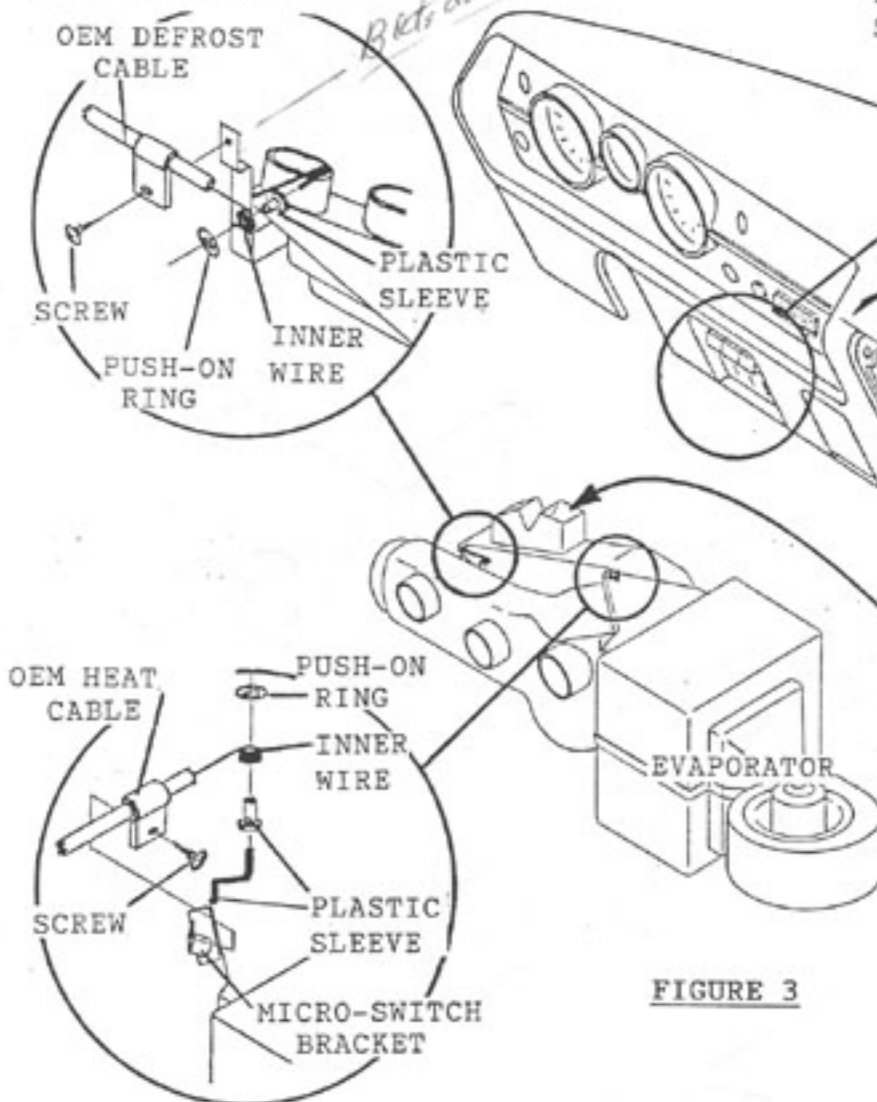

FIGURE 1

OEM CONTROL OPERATION



OEM CABLE INSTALLATION



NOTE: The defrost plenum slips inside the OEM defrost duct upon installation.

FIGURE 3

CABLE LENGTHS

DEFROST:

eye-to-eye 13½"
casing 10½"

HEAT-A/C

eye-to-eye 29½"
casing 26½"

OEM CABLE INSTALLATION

Attach the control cables as shown in diagram above.

OEM CONTROL OPERATION

The operation of the OEM controls is shown in diagram above.

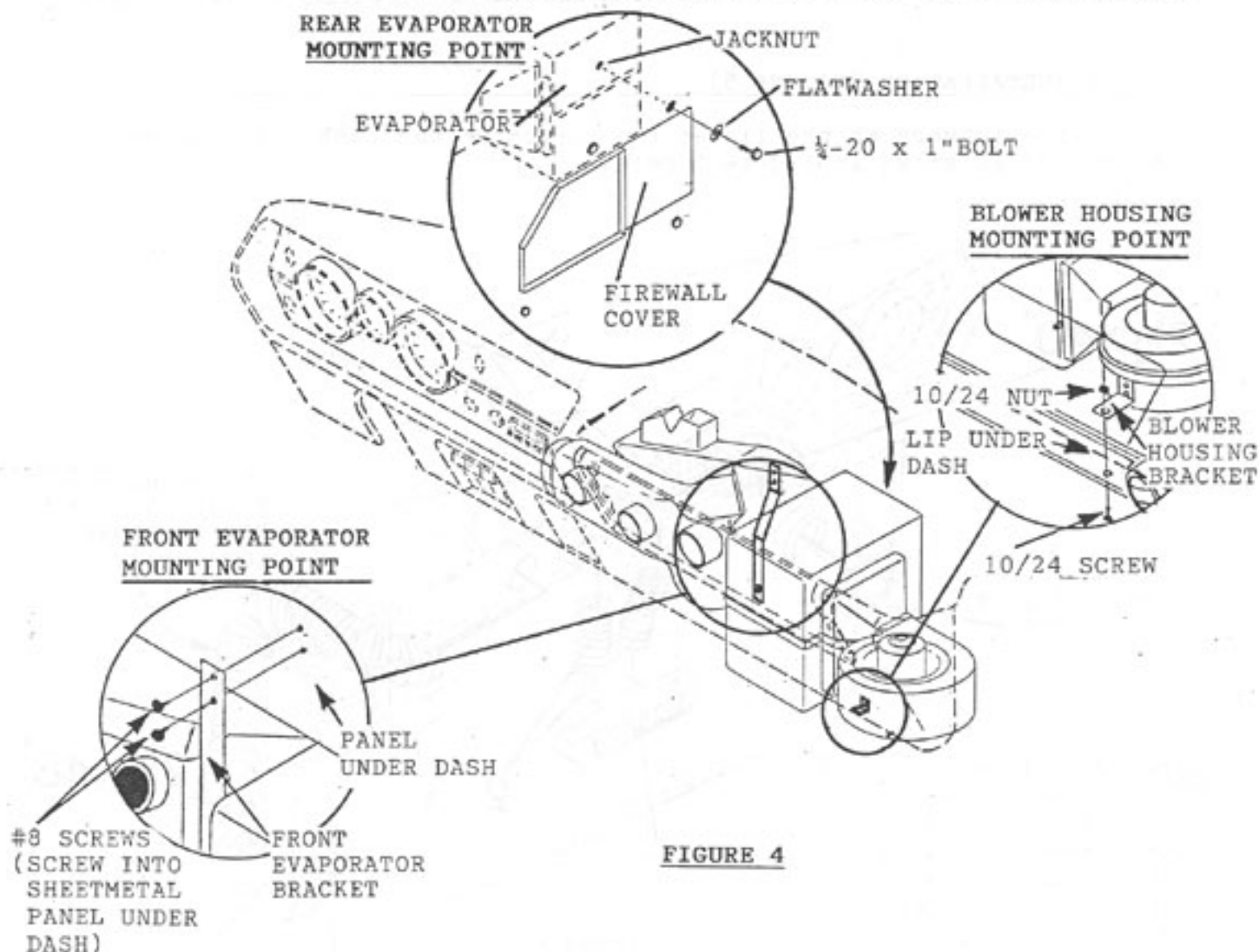
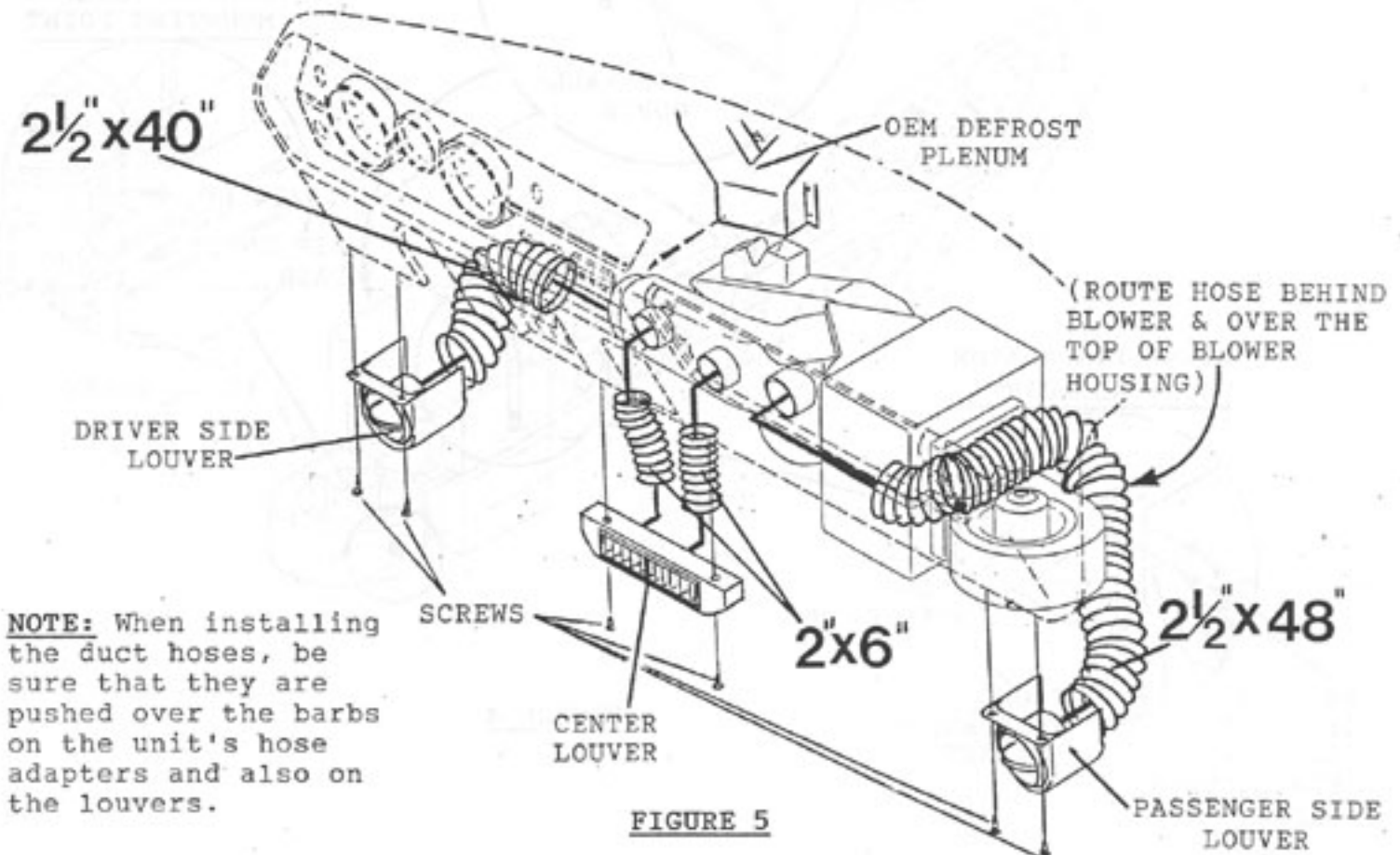

FIGURE 4

1. REAR EVAPORATOR MOUNTING POINT- Position the evaporator unit under the dash and install a 1/2"-20 x 1" bolt with washer (supplied) through the firewall cover (mounted to firewall) into the jacknut in the back of the unit.
2. BLOWER HOUSING MOUNTING POINT- Next, attach the blower housing bracket to the lip under the front edge of the dash using a 10/24 x 1/2" machine screw and nut (supplied). (Be sure that the bracket is on top of the lip so it won't show under the dash.)
3. FRONT EVAPORATOR MOUNTING POINT- Now, make sure that the unit is level then mark the holes in the front evaporator bracket onto the sheetmetal panel under the dash. Drill (2) 1/8" pilot holes through the panel where the points are marked. Attach the bracket using (2) #8 x 1/2" sheetmetal screws (supplied).

LOUVER INSTALLATION (FIGURE 5)

Attach the louvers to the lip at the bottom of the dash using screws (supplied) as shown in Figure 5 below.



NOTE: When installing the duct hoses, be sure that they are pushed over the barbs on the unit's hose adapters and also on the louvers.

FIGURE 5

DUCT HOSE ROUTING & INSTALLATION (FIGURE 5)

Stretch duct hose out to maximum length and cut the lengths indicated in Figure 5. Route all hoses and attach to the appropriate outlets as Figure 5 shows.

NOTE: With the unit in place, stretch the duct hoses tightly to their corresponding outlets on the unit and recheck their lengths. Make sure that the hoses are pulled tightly with a minimum of kinks and sharp bends. This will insure maximum air-flow.

WIRING

To wire unit follow the WIRING DIAGRAM at the end of this instruction manual.

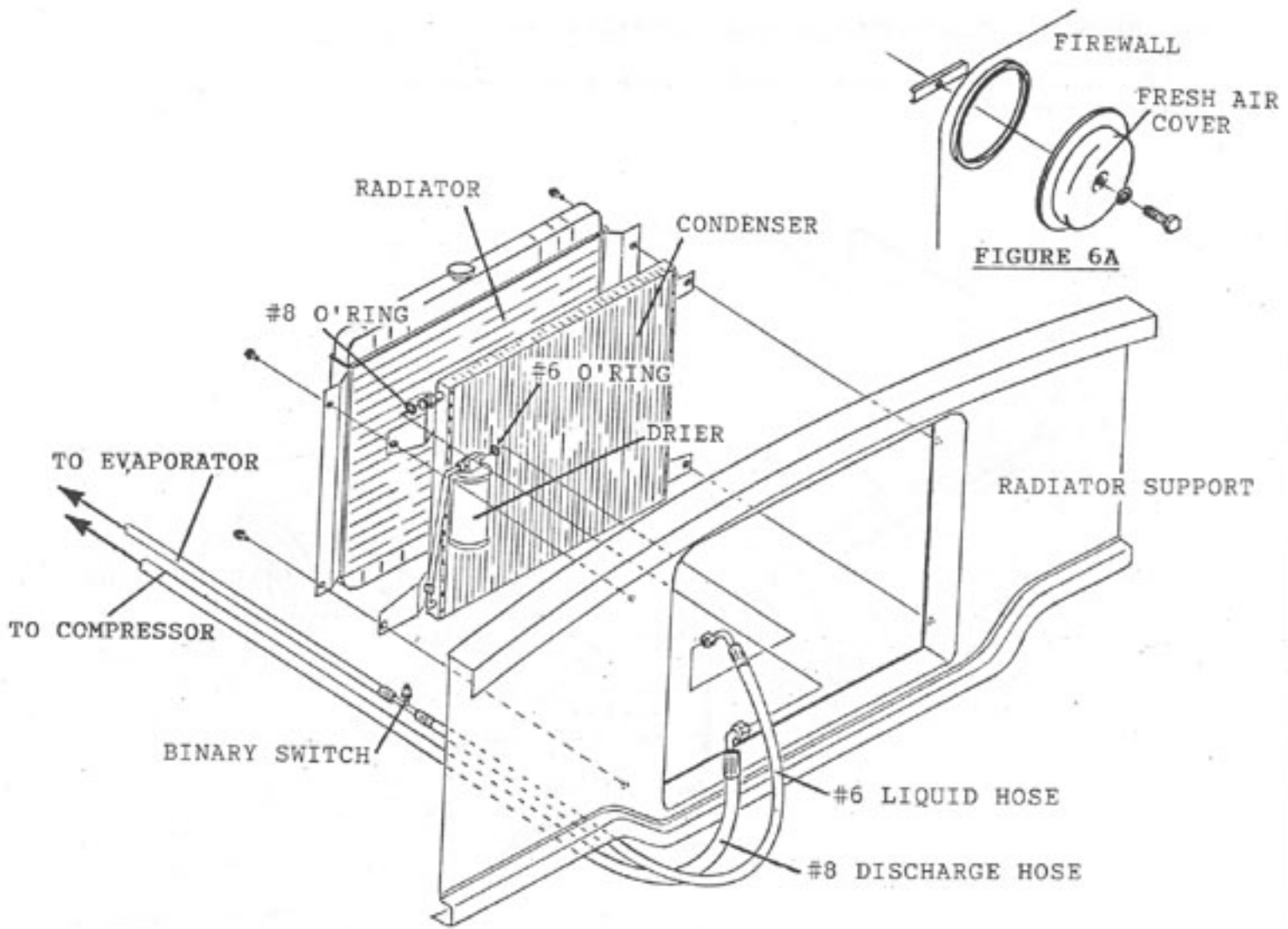

FIGURE 6

CONDENSER INSTALLATION (FIGURE 6)

1. Drain and remove the radiator.
2. Locate the condenser assembly in the radiator opening of the core support.
3. Re-install the radiator making sure to pick-up the mounting points of the condenser with the mounting points of the radiator.
4. Route the #8 Discharge Hose and the #6 Liquid Hose around the bottom of the radiator core support.
5. Lubricate and attach the #8 Discharge Hose to the upper fitting on the condenser and the #6 Liquid Hose to the Drier outlet.

FRESH AIR COVER INSTALLATION (FIGURE 6A)

1. Run a bead of silicone around the perimeter of the fresh air cover.
2. Install the cover over the opening left by the OEM blower motor under the fenderwell.

COMPRESSOR & COMPRESSOR BRACKET INSTALLATION

Follow the instructions supplied with the compressor and the compressor bracket for installation.

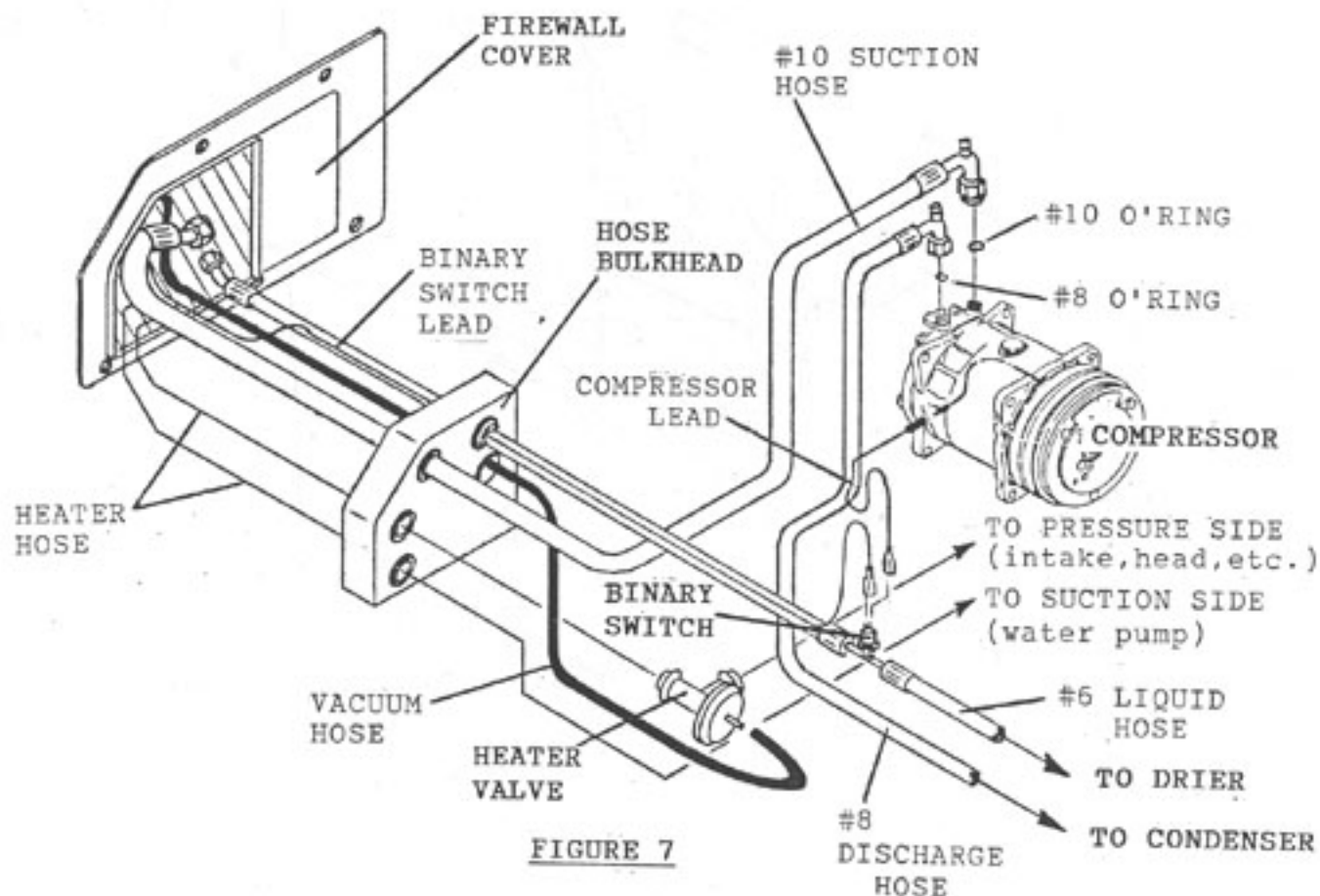

FIGURE 7

REFRIDGERATION HOSE ROUTING & INSTALLATION (FIGURE 7) & (FIGURE 6) pg.7

1. Lubricate and attach the #10 SUCTION HOSE from the evaporator to the compressor (1/2" I.D. hose 25" long, 45 female O'RING fitting on the evaporator end and 90 female O'RING (134a SV. PORT) fitting on the compressor end.)
2. Lubricate and attach the #8 DISCHARGE HOSE from the condenser to the compressor (13/32" I.D. hose 45" long, 90 female O'RING (134a SV. PORT) fitting on the compressor end and 90 female O'RING fitting on the condenser end.)
3. Lubricate and attach the #6 LIQUID HOSE from the evaporator to the drier (5/16" I.D. hose 61" long, 90 female O'RING fitting on the drier end and 45 female O'RING fitting on the evaporator end.)

HEATER HOSE & HEATER VALVE INSTALLATION (FIGURE 7)

Follow Figure 7 for the installation of the heater valve and the heater hoses (not supplied).

DRAIN HOSE INSTALLATION (FIGURE 8A)

Drill a 5/8" hole 1" below the evaporator unit and in-line with the drain tube in the bottom of the evaporator unit. Install the rubber grommet (supplied) in the hole then install the 1/2" drain hose (supplied) thru the grommet and attach to the drain tube on the unit.

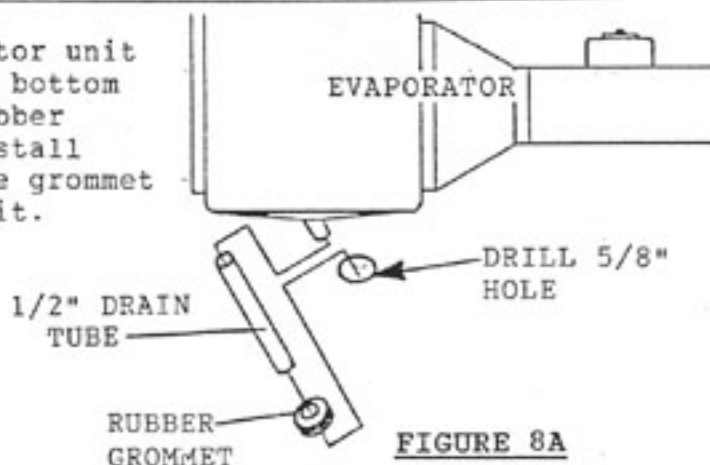

GLOVE BOX INSTALLATION (FIGURE 8B)

1. Install the glove box bottom into the opening in the dash.
2. Install the glove box top into the opening in the dash.
3. Attach the top of the glove box to the bottom of the glove box using screws (supplied).
4. Attach the assembly to the OEM locations using the OEM screws.

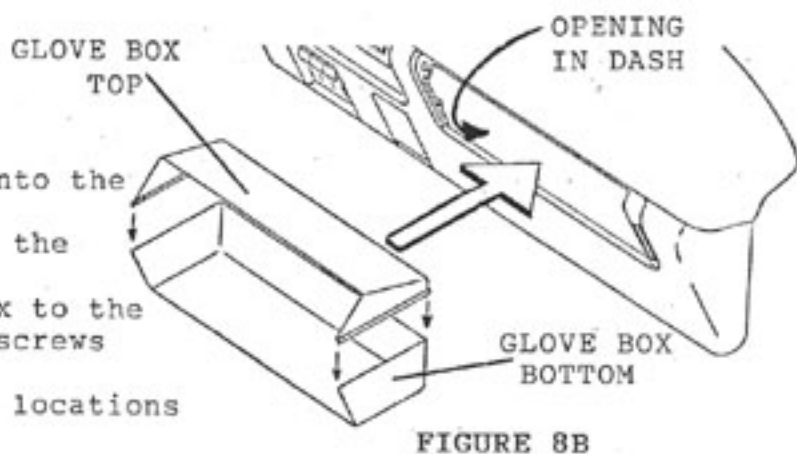

CONCLUSION

1. Re-attach all items previously removed.
2. Double-check all fittings, brackets, and belts for tightness.
3. Evacuate system for at least 30 minutes prior to charging the system.
4. As always, Vintage Air recommends that all A/C systems be serviced by certified automotive air conditioning technicians only.

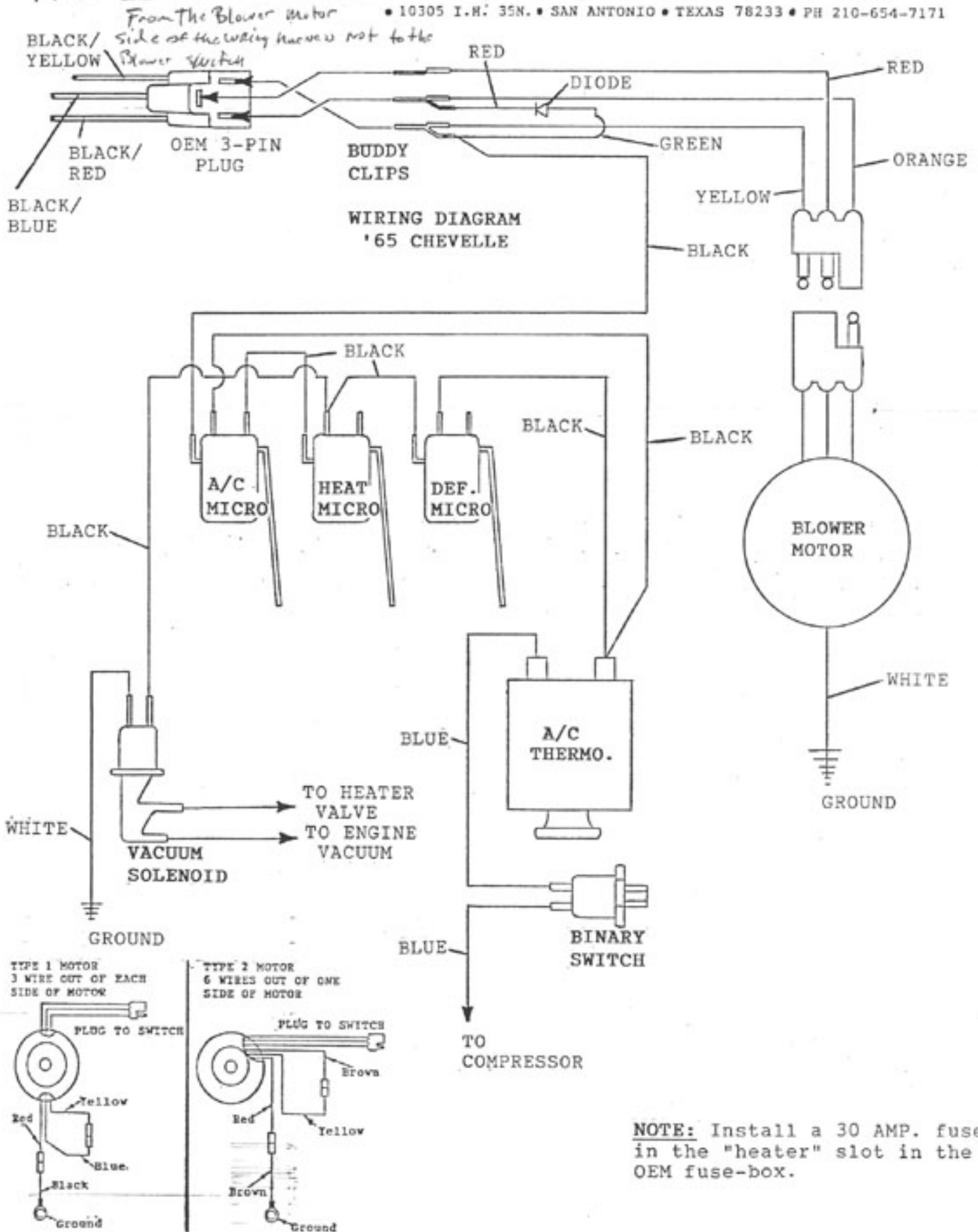

NOTE: Install a 30 AMP. fuse in the "heater" slot in the OEM fuse-box.

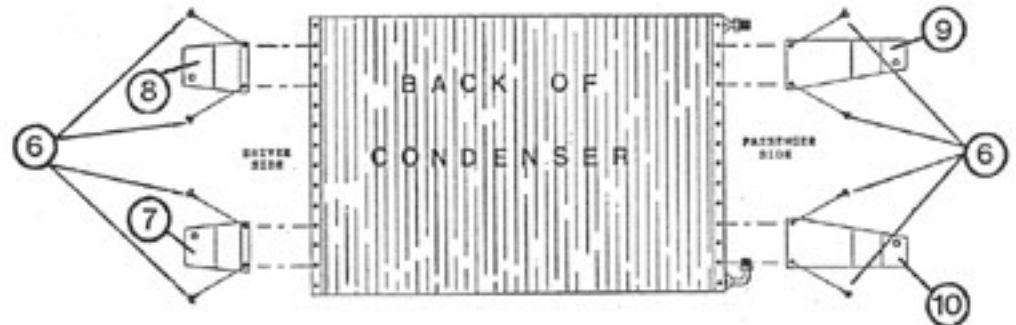
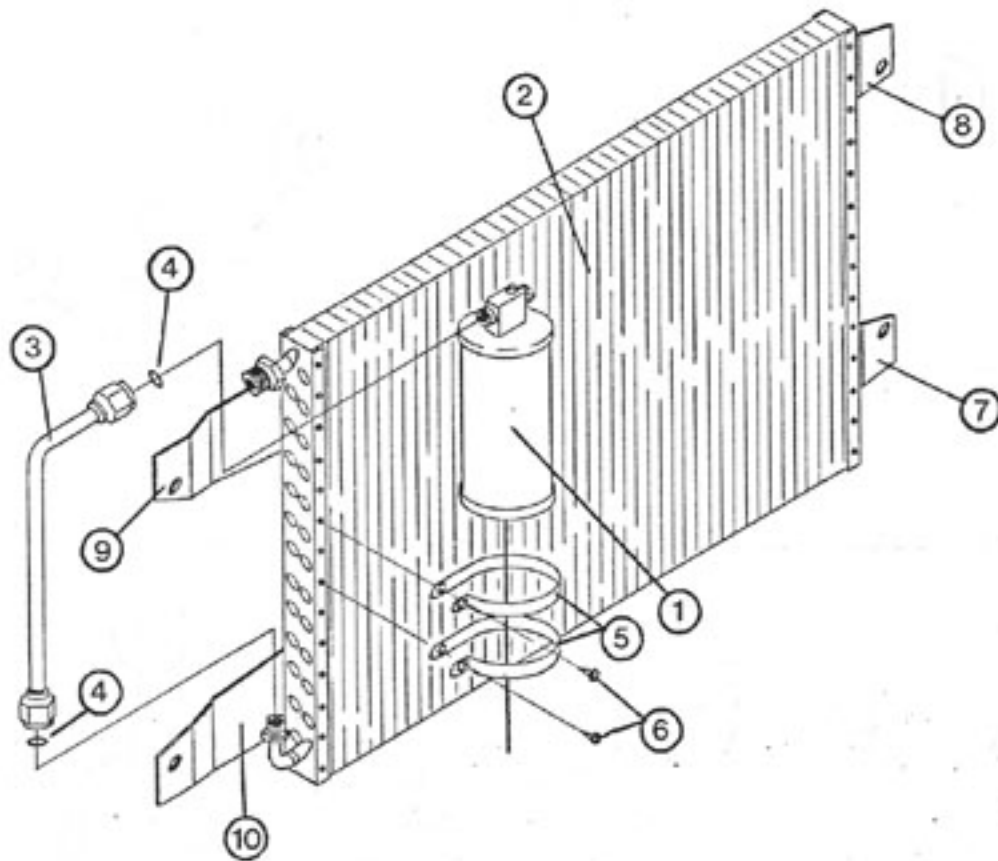

RADIATOR OPENING

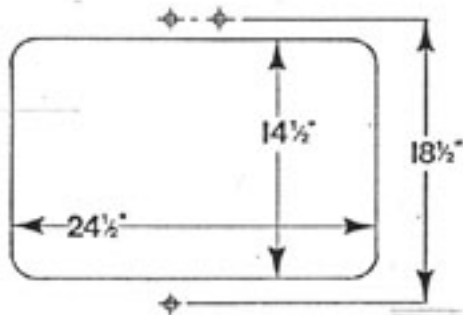

		'65 CHEVELLE (w/o Fac. A/C) (03164-VCC)	
		CONDENSER KIT (w/Drier) (03164-VCC-A)	
- PACKING LIST -			
NO	QTY	PART NUMBER	DESCRIPTION
1	1	07321-VUC	Drier
2	1	03050-VUC	Condenser (Tube & Fin)
3	1	35007-VCG	'65 CHEVELLE DRIER FITTING
4	2	33857-VUF	#6 O-Ring
5	2	07113-VUB	Drier Clamp
6	10	18247-VUB	#10 Sheetmetal Screw
7	1	65142-VCB	Cond. Bracket (D.S. Bottom)
8	1	65143-VCB	Cond. Bracket (D.S. Top)
9	1	65144-VCB	Cond. Bracket (P.S. Top)
10	1	65145-VCB	Cond. Bracket (P.S. Bottom)

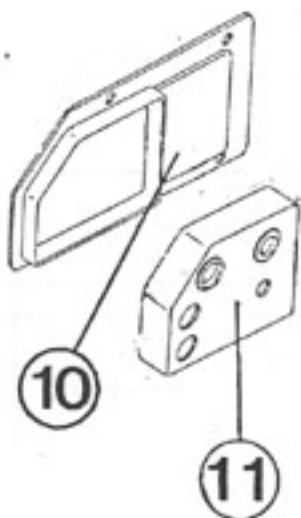
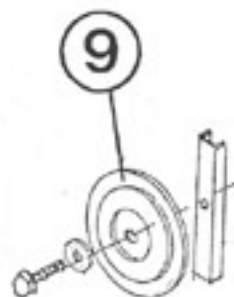
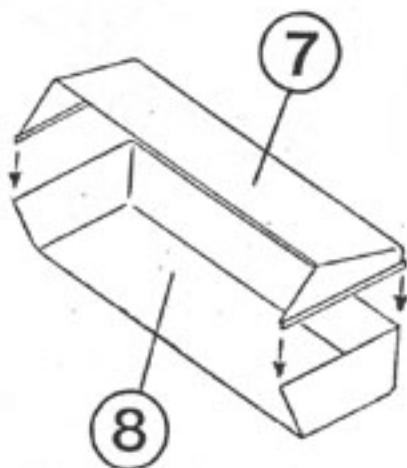
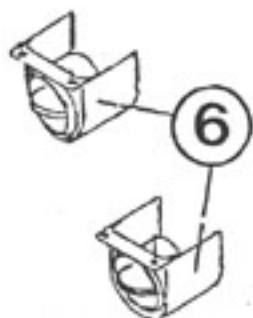
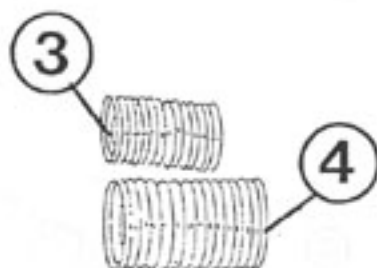
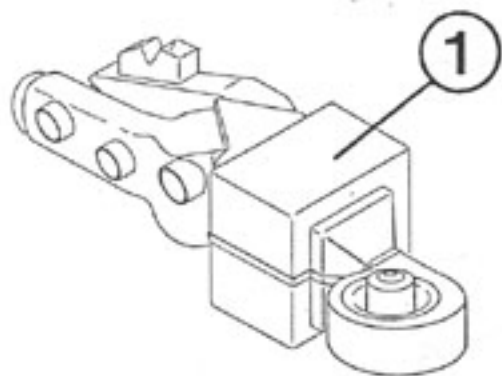

D.O.#		55065-VCZ	
		'65 CHEVELLE (w/out fac. A/C)	
PACKING LIST			
NO	QTY	PART NUMBER	DESCRIPTION
1	1	55365-VCE	EVAPORATOR w/WIRING & BRACKETS
2	1	63259-VCE	64-65 CHEVELLE DRAIN KIT W/O AIR
3	1	06200-VUE	2" x 1' DUCT HOSE
4	1	06250-VUE	2½" x 7½' DUCT HOSE
5	1	62347-VFE	CENTER LOUVER
6	2	49054-VUL	SIDE LOUVER
7	1	62379-VCE	GLOVE BOX TOP
8	1	62380-VCE	GLOVE BOX BOTTOM
9	1	49864-VCI	FRESH AIR COVER
10	1	62220-VCI	FIREWALL COVER
11	1	62221-VCI	FIREWALL BULKHEAD

DATE : _____
 CHECKED : _____
 PACKED : _____