

VANTAGE AIR

18865 GOLL ST. - SAN ANTONIO, TX. - 78266 - ph.210-654-7171 - fax.210-654-3113

CONTROLLED DOCUMENT

DATE: 2.17.03

BI-LEVEL HEATER

w/ DEFROST

(50616-VUZ)

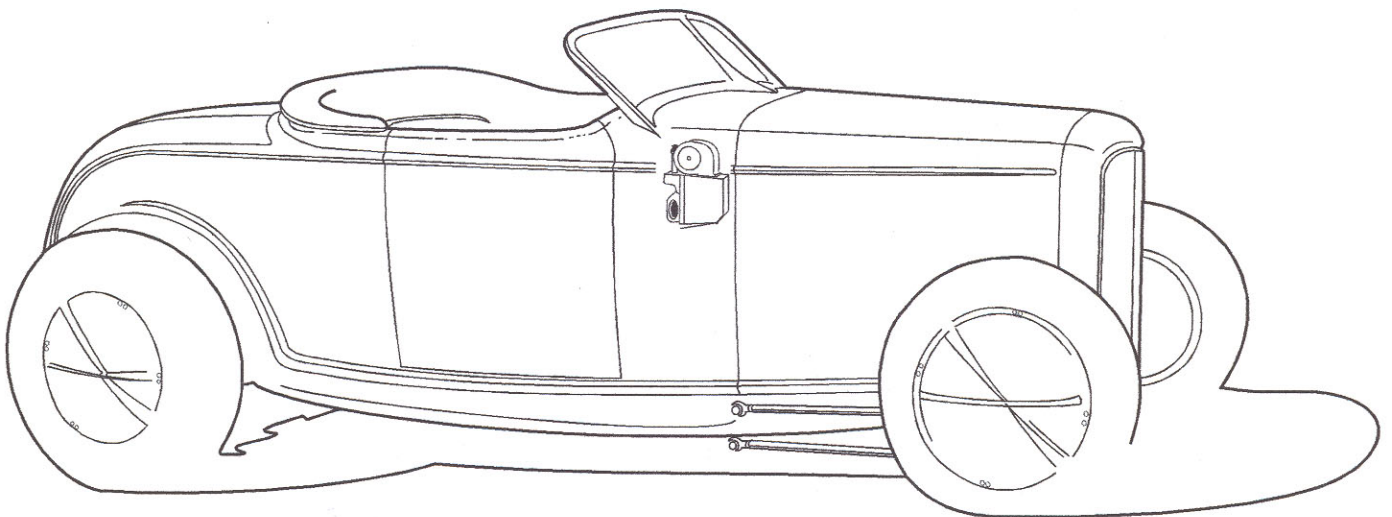

Table of Contents

PAGES

1. COVER
2. TABLE OF CONTENTS
3. PACKING LIST
4. INSTALLATION
5. TEMPLATE
6. HEATER HOSE
7. DEFROST DUCT INSTALLATION
8. OPTIONAL UNDER DASH BALL LOUVER
9. WIRING DIAGRAM
10. HEATER KIT PACKING LIST

50616-VUZ PACKING LIST

No.	QTY.	PART No.	DESCRIPTION
1.	1	50600-VUA	HEATER w/ DEFROST SUB CASE
2.	1	23303-VUA	HEATER/DEFROST WIRING KIT
3.	1	63563-VUA	INSTALLATION KIT
4.	1	63380-VUE	COMPAC DEFROSTER DUCTS
5.	5	06200-VUE	2" DUCT HOSE

**** BEFORE BEGINNING INSTALLATION OPEN ALL PACKAGES AND CHECK CONTENTS OF SHIPMENT. PLEASE REPORT ANY SHORTAGES DIRECTLY TO VINTAGE AIR WITHIN 15 DAYS. AFTER 15 DAYS, VINTAGE AIR WILL NOT BE RESPONSIBLE FOR MISSING OR DAMAGED ITEMS.**

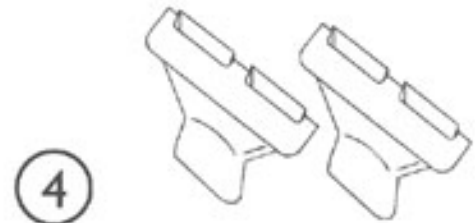
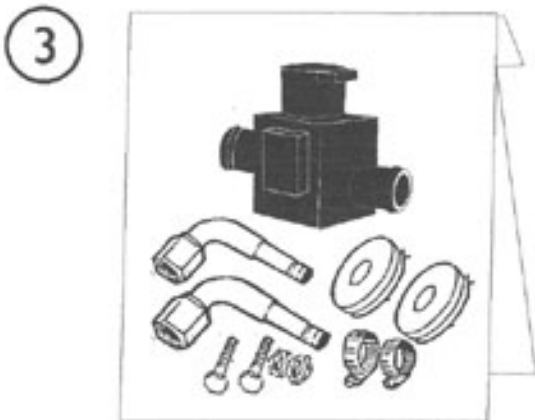
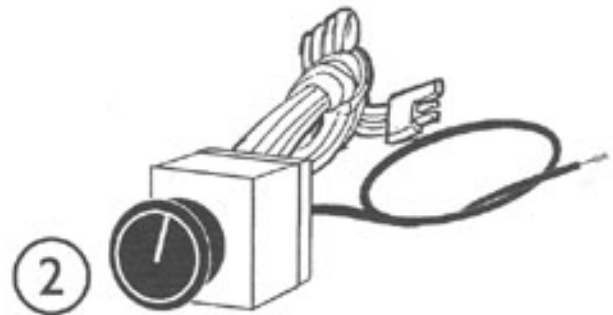
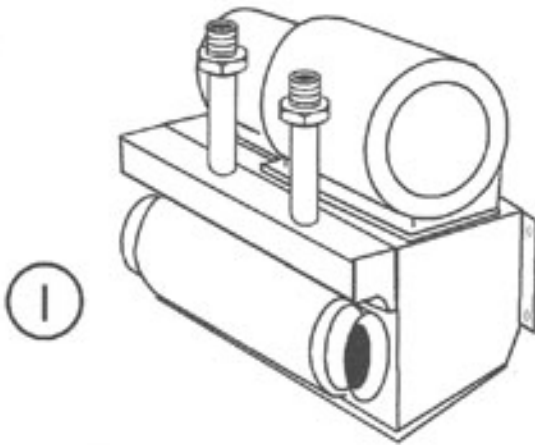

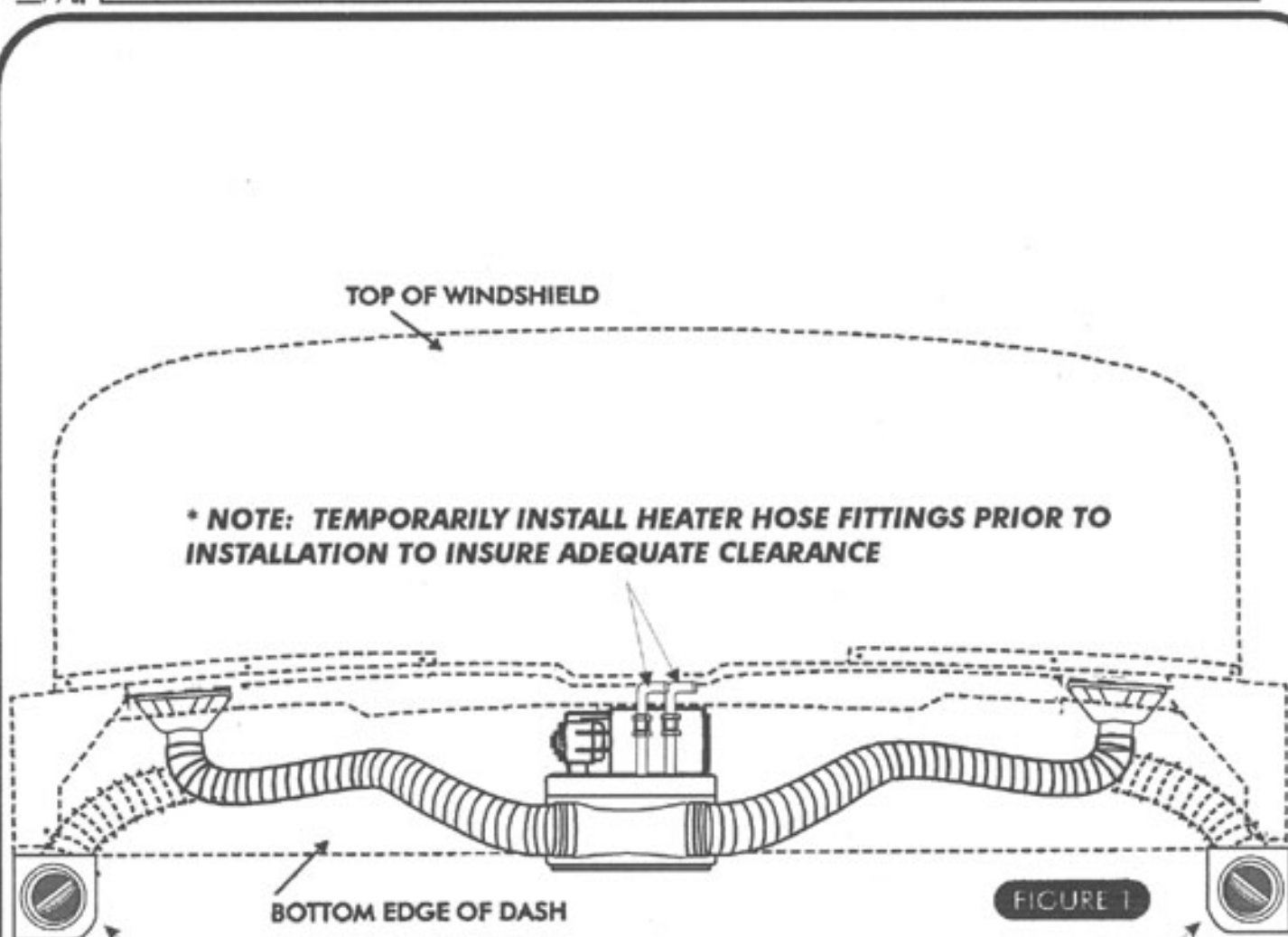

*** NOTE: TEMPORARILY INSTALL HEATER HOSE FITTINGS PRIOR TO INSTALLATION TO INSURE ADEQUATE CLEARANCE**

INSTALLATION INSTRUCTIONS

HEATER w/ DEFROST

THE VINTAGE AIR HEATER UNIT IS DESIGNED TO MOUNT INSIDE OF THE FIREWALL IN THE PASSENGER COMPARTMENT. THE INSTALLATION OF THIS UNIT VARIES ACCORDING TO BODY MANUFACTURER OR MODIFICATIONS TO ORIGINAL FIREWALL. AFTER SELECTING LOCATION (BE SURE UNIT DOES NOT INTERFERE WITH COWL VENT, WIPERS, ETC.) USE TEMPLATE TO LOCATE AND DRILL (3) 9/32" DIAMETER MOUNTING HOLES (SEE PAGE 5).

SEE PAGE 6 FOR HEATER HOSE ROUTING INSTRUCTIONS



TOP

9/32" MOUNTING HOLES

FIREWALL MOUNTING TEMPLATE

9/32" MOUNTING HOLES

USING THIS TEMPLATE
DRILL (3) 9/32" HOLES
IN FIREWALL

HEATER HOSE INSTALLATION

- INSTALL HEATER FITTINGS WITH O-RINGS(LUBRICATED) TO HEATER CORE. SEE FIGURE 2, BELOW
- AFTER THE HEATER IS IN PLACE, RUN 5/8" HEATER HOSE FROM THE LEFT HEATER FITTING THRU FIREWALL OR BEHIND KICK PANEL THRU FLOOR TO THE INTAKE MANIFOLD HEATER CONNECTION. INSTALL THE ELECTRIC HEATER CONTROL VALVE IN THIS LINE. SEE FIGURE 2.
- INSTALL 5/8" HEATER HOSE ON RIGHT FITTING OF HEATER THRU FIREWALL OR BEHIND KICK PANEL THRU FLOOR BOARD AND OUT TO THE WATER PUMP CONNECTION.
- FILL RADIATOR WITH COOLANT. CHECK ALL HEATER CONNECTIONS FOR LEAKS.
- START ENGINE AND RUN UNTIL NORMAL OPERATING TEMPERATURE IS REACHED. PLACE SWITCH IN DESIRED HEAT POSITION (SEE FIGURE 6, PAGE 9) AND SELECT FAN SPEED. THE SYSTEM WILL HEAT THE VEHICLE.
- WHEN VALVE IS CLOSED INLET SIDE OF VALVE SHOULD BE HOT AND OUTLET SIDE SHOULD BE COOL. WHEN THE VALVE IS OPEN BOTH INLET AND OUTLET SHOULD BE HOT.

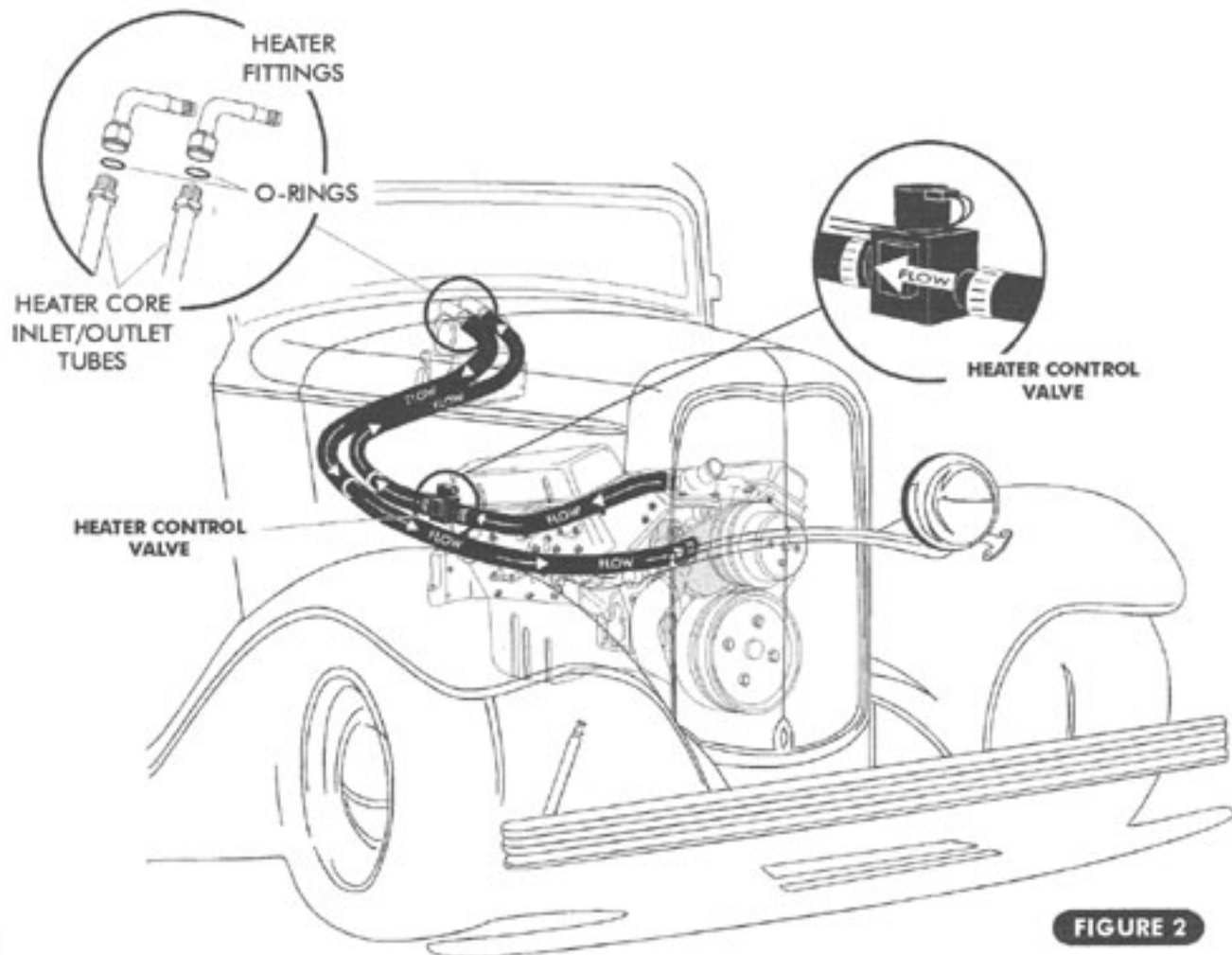

FIGURE 2

DEFROST DUCTS INSTALLATION

- FIGURE 3 SHOWS GENERAL LOCATIONS OF DEFROSTER DUCT HOLES. THE LOCATION OF THESE DUCTS WILL VARY.

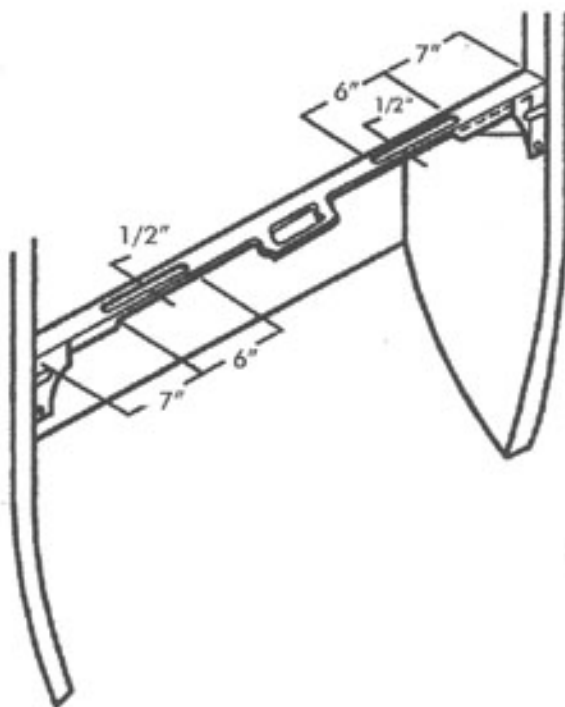

FIGURE 3

- INSTALL THE DEFROST DUCTS AS SHOWN IN FIGURE 4, BELOW

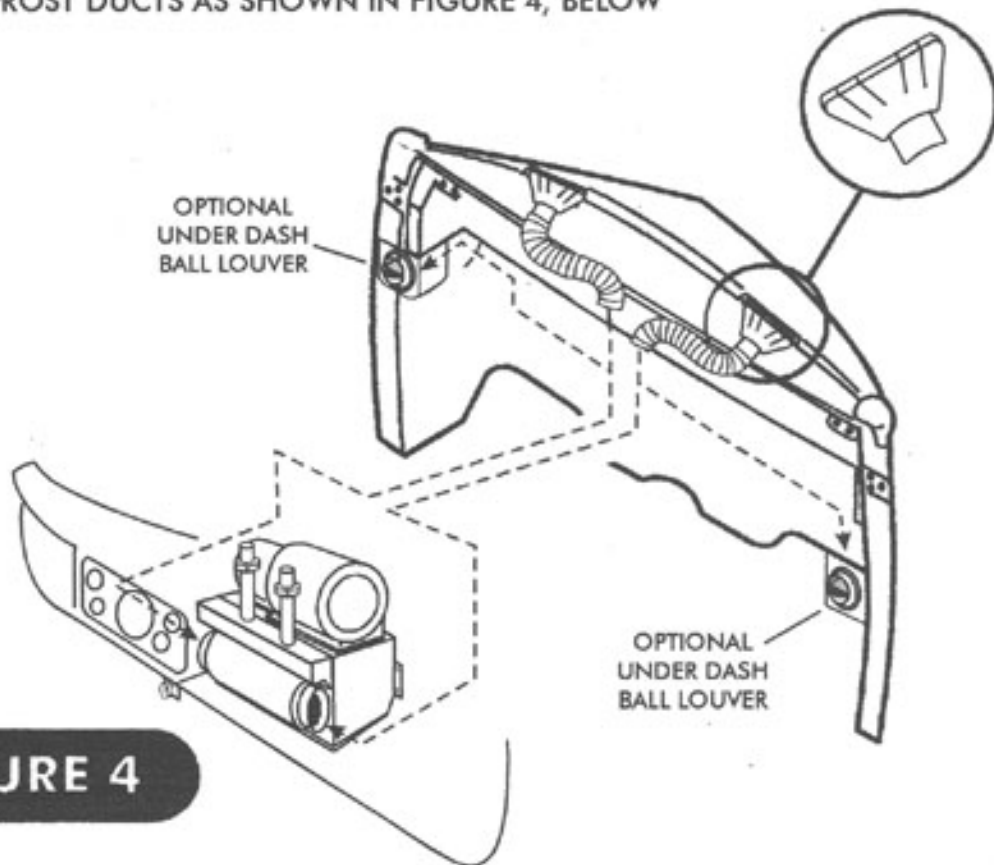

FIGURE 4

OPTIONAL UNDER DASH BALL LOUVER INSTALLATION

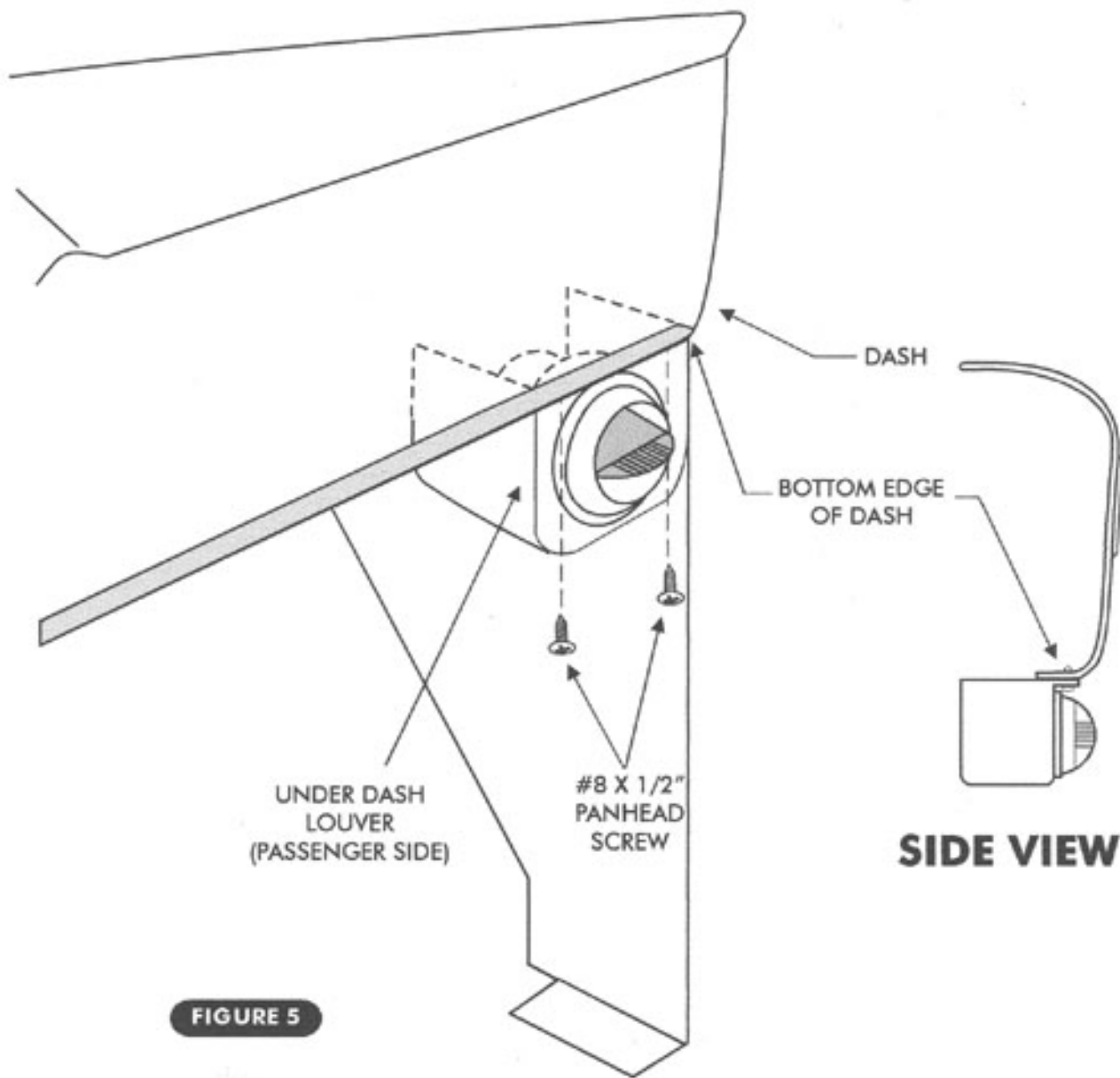
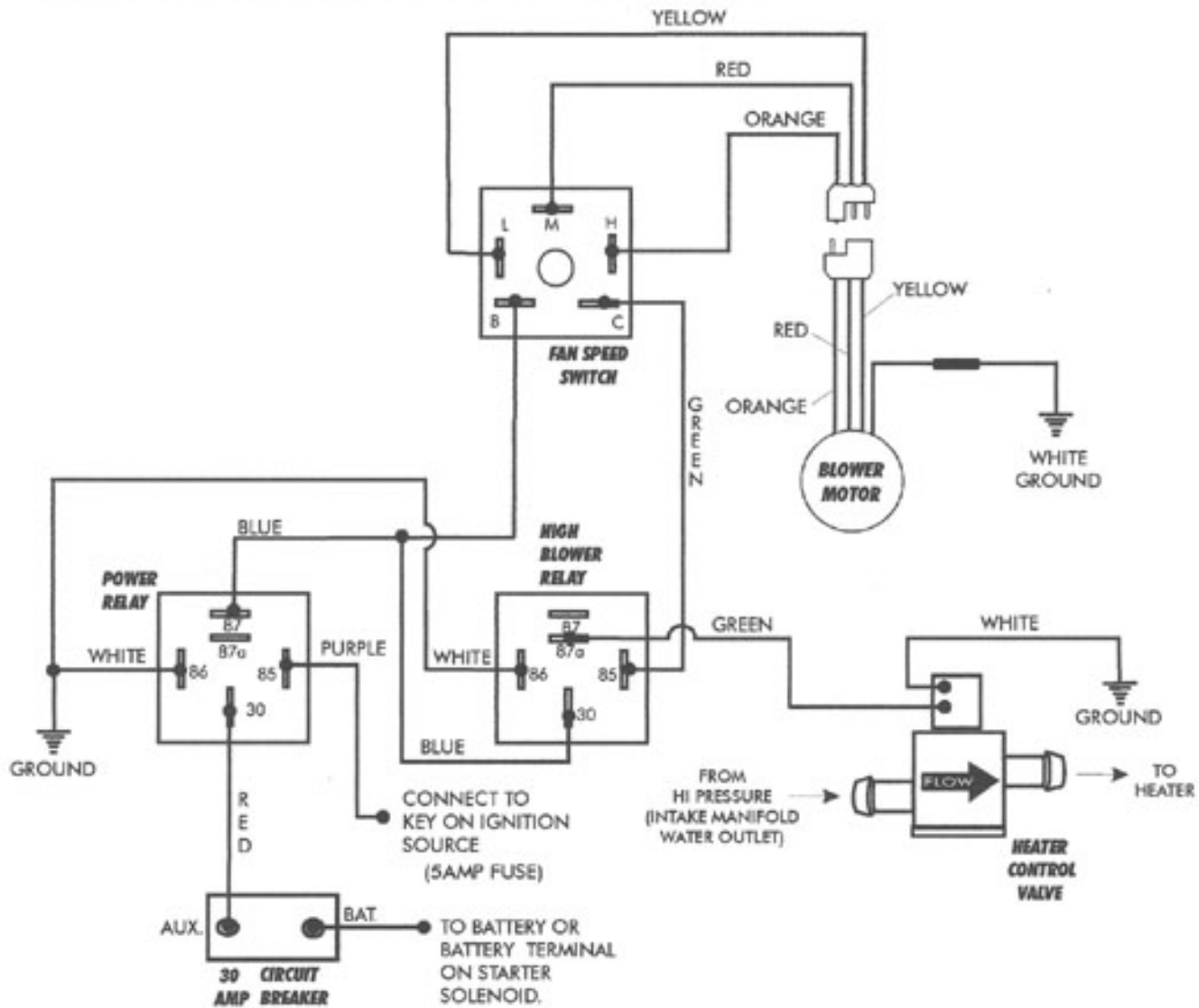

FIGURE 5

*** DRIVER SIDE LOUVER WILL BE INSTALLED SAME WAY.**

WIRING DIAGRAM - UNIVERSAL UNIT

HEATER w/DEFROST (ELECTRIC HEATER CONTROL VALVE)



3 SPEED FAN MOTOR BLOWER CONTROL SWITCH

TO OPERATE FLOOR HEAT MODE PUSH KNOB IN, AND ROTATE KNOB TO DESIRED FAN SPEED
 TO OPERATE DEFROST MODE PULL KNOB OUT, AND ROTATE KNOB FOR DESIRED FAN SPEED

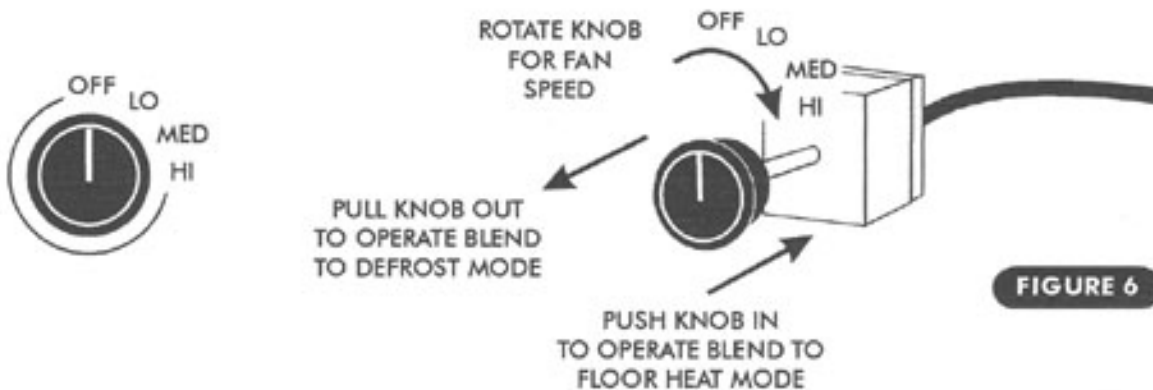

FIGURE 6

50616-VUZ PACKING LIST

No.	QTY.	PART No.	DESCRIPTION
1.	1	50600-VUA	HEATER w/ DEFROST SUB CASE
2.	1	23303-VUA	HEATER/DEFROST WIRING KIT
3.	1	63563-VUA	INSTALLATION KIT
4.	1	63380-VUE	COMPAC DEFROSTER DUCTS
5.	5	06200-VUE	2" DUCT HOSE

CHECKED BY: _____
 PACKED BY: _____
 DATE: _____

